



4270107667

# 1498 Inactive Device

# FALCON®

Installation Instructions

## Prepare door and Install device.

1. Prepare door as shown in Figure 1 below.
2. Cut pushbar as shown on reverse side of sheet.
3. Install mounting plate loosely on hinge stile (knobs facing stile) with #12-24 screws (See Figure 2 below). Do not fully tighten until final adjustments are made.
4. Slide pushbar assembly into mounting plate on hinge stile.
5. Install mounting plate (knobs facing stile) on lock stile with #12-24 screws.
6. Install channel end caps on both ends (knobs of mounting plates fit into channel end caps). Tighten #12-24 screws.
7. Install pushbar end caps.
8. Apply "push" label.

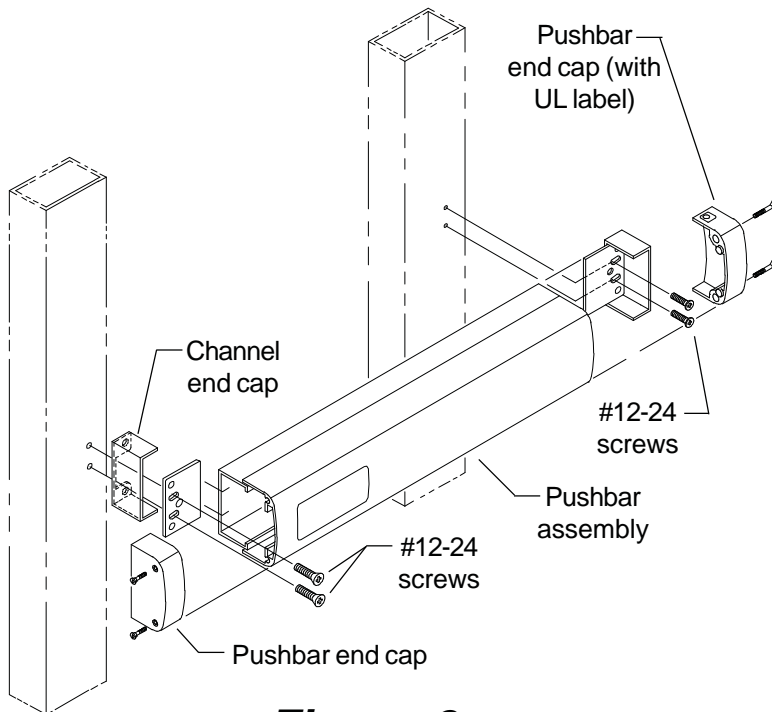

**Figure 2**

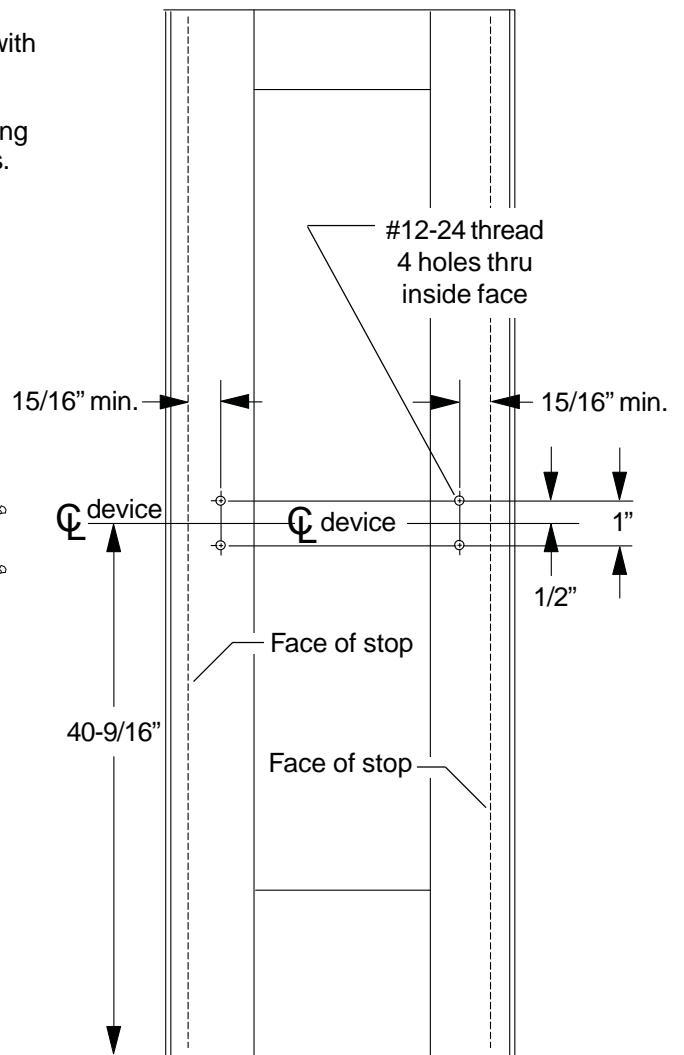

**Figure 1**



Customer Service

1-877-671-7011

[www.allegion.com/us](http://www.allegion.com/us)

© Allegion 2014  
Printed in U.S.A.  
4270107667 Rev. 10/14-d

## Cut pushbar to length.

1. Measure  $\text{C}$  to  $\text{C}$  of mounting holes ("A" dimension Figure 3).
2. Subtract  $1/2"$  from "A" dimension to determine cut length ("B" dimension in Figure 3 and 4). See chart below for minimum "B" dimension.

Device Length	"B" Dimension Supplied	Minimum "B" Dimension
36" device	32-5/8"	21"
42" device	38-5/8"	21"
48" device	44-5/8"	30"

3. Tape around channel and pushbar in cutoff area, and mark "B" dimension on tape (see Figure 4).
4. Keep chips out of mechanism by stuffing a rag into end of pushbar before cutting. Keep rag out of the path of the saw. Cut pushbar and channel, deburr, and clean chips from pushbar and channel.
5. Pull the two rubber bumper strips from the screw grooves, cut off 1" so the bumper strips are 1" shorter than the pushbar, and reinstall bumper strips into screw grooves.
6. Tap #8-32 x 1" deep into each screw groove in end of pushbar.
7. See reverse side for installation.

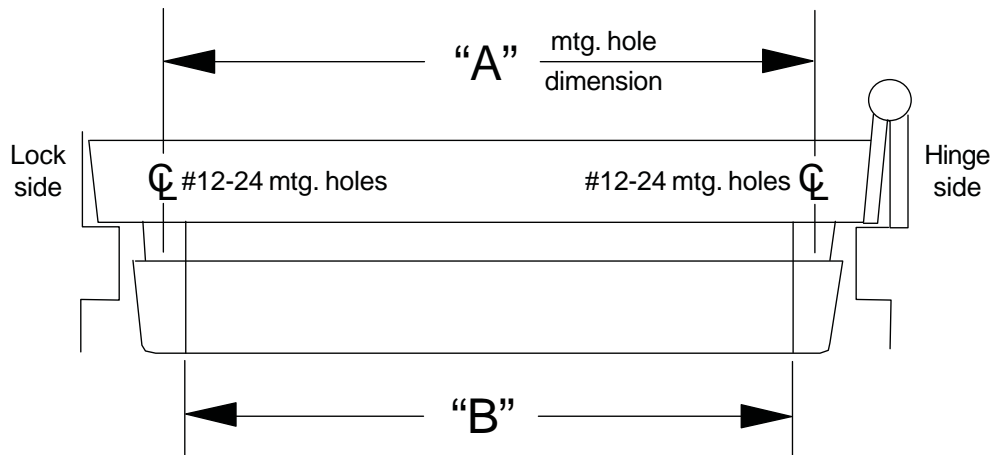

**Figure 3**

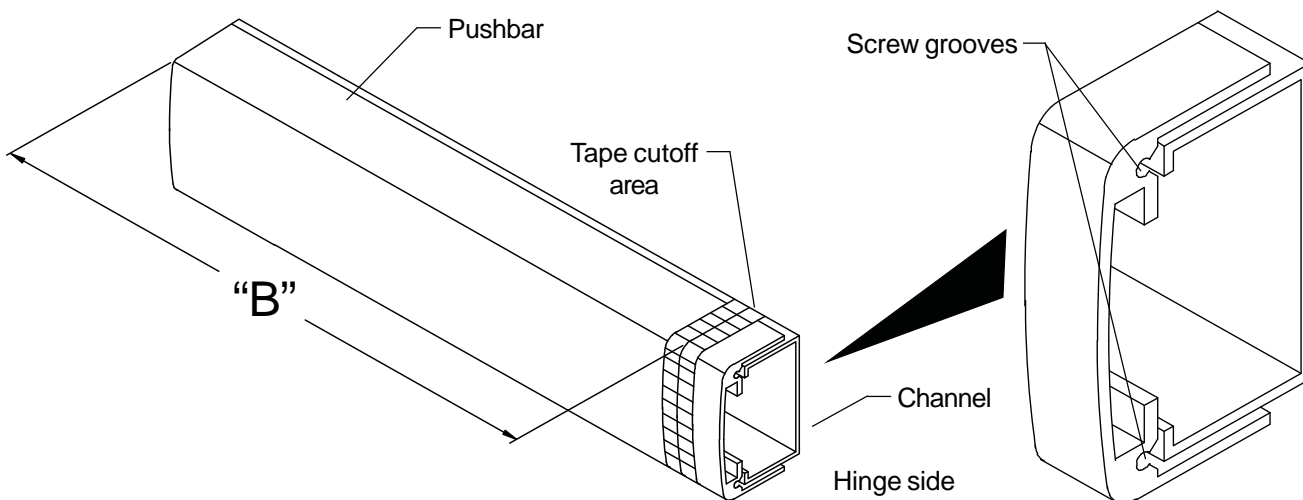

**Figure 4**