





190DT DEVICE OR 190DT DEVICE x ACTIVE TOUCHBAR INSTALLATION INSTRUCTIONS

FALCON®

190 DT
D-4317-B
Date: 05-29-2015

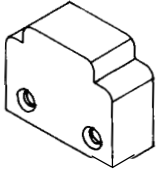
1 PARTS CHECK

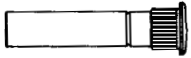
1. MAKE SURE THE CORRECT DEVICE IS BEING USED AND ALL NEEDED PARTS ARE ON HAND.
NOTE: LIST DOES NOT REFLECT ALL POSSIBLE APPLICATIONS.

1. 190DT DEVICE 		2. CHANNEL END CAP (2 QTY.) 	
3. MOUNTING BRACKET (2 QTY.) 	4. SEXBOLT (2 QTY.) 	5. 1/4"-20x3/4" TPHMS (2 QTY.) 	6. #8-32x3/8" UFPHMS w/ NYLON PATCH (4 QTY. - BLACK) 

2 DOOR LAYOUT

1. DOOR MUST BE FITTED AND HUNG PROPERLY BEFORE PROCEEDING.
2. MARK VERTICAL \mathcal{C} AND DEVICE REF \mathcal{C} ON DOOR (SEE FIGURE BELOW).

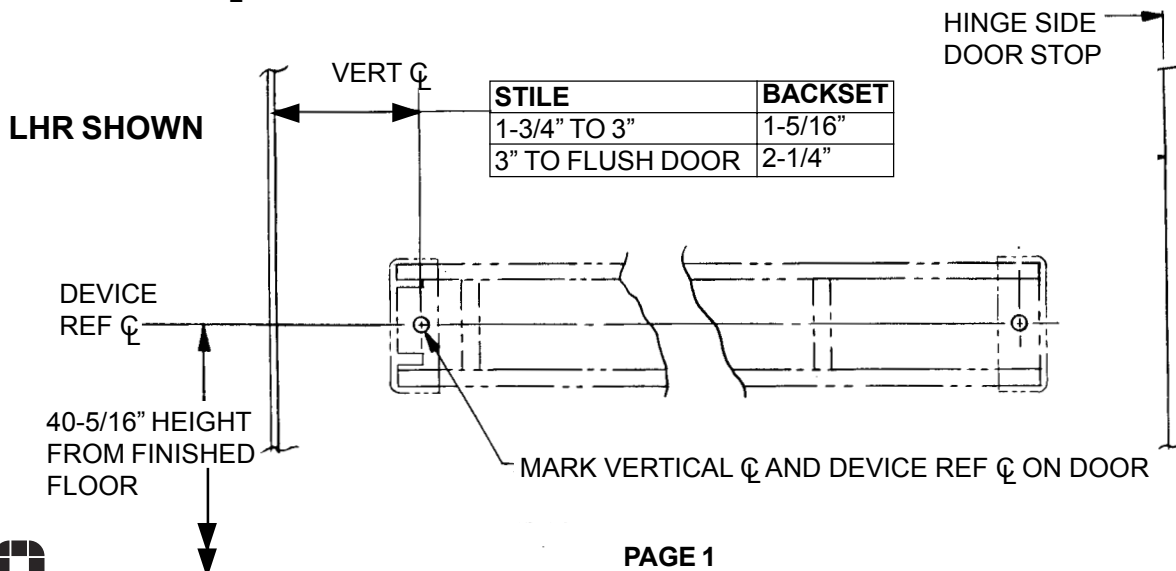

3 DOOR & HARDWARE PREPARATION

1. DRILL 9/32" DIA. HOLE INSIDE AND 3/8" DIA. HOLE OUTSIDE AT LOCATION MARKED IN 2 .
 FOR WOOD DOORS, DRILL 3/8" DIA. HOLE THRU.

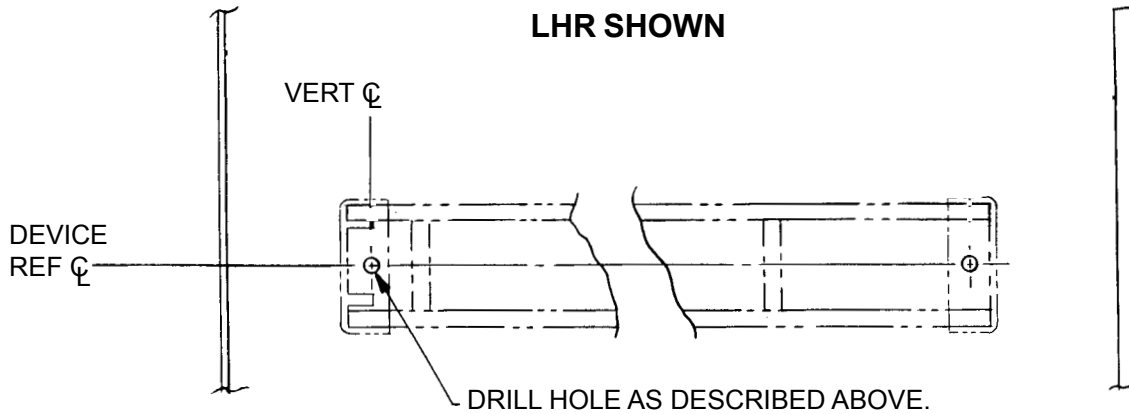

2. DETERMINE DEVICE LENGTH.
- A. MEASURE DISTANCE FROM VERTICAL C TO STOP SURFACE ON HINGE SIDE OF DOOR ("Y" - BELOW).
- B. SUBTRACT 1" FOR RECOMMENDED CLEARANCE (FOR STILES LESS THAN 2-3/4" WIDE, SUBTRACT 3/4").
- C. LENGTH OF DEVICE FROM VERTICAL C TO CUT-OFF LENGTH IS "X".

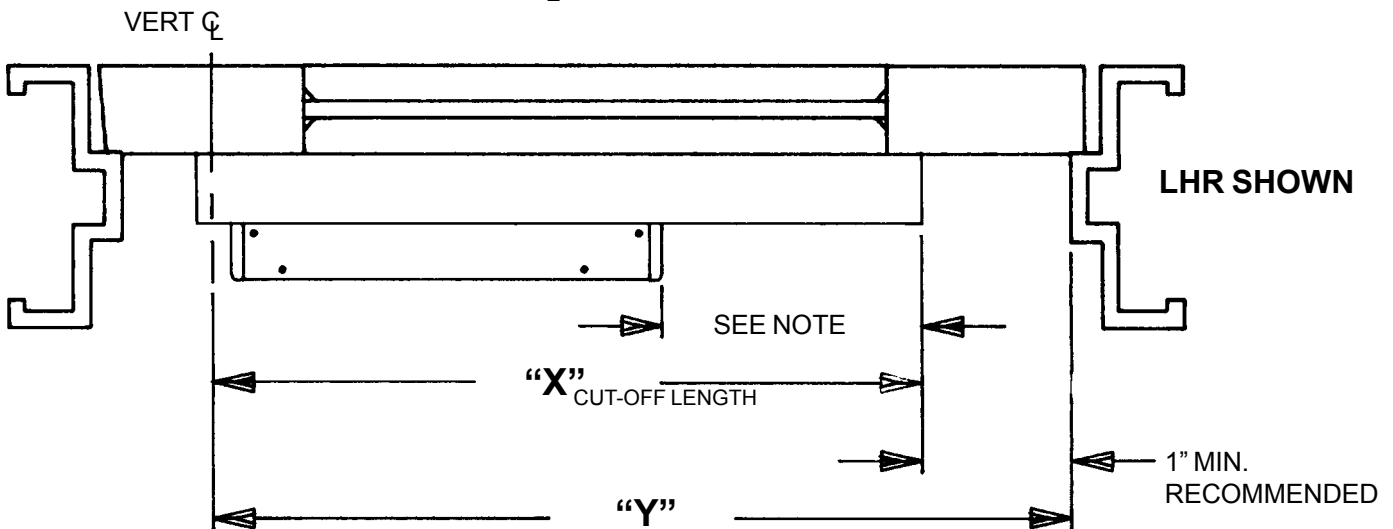

NOTE:

- FOR STANDARD 190DT OR 190DT x ACTIVE TOUCHBAR: 1-3/4" MIN.
- FOR 190DT x ACTIVE TOUCHBAR WITH STANDARD DOGGING: 3" MIN.
- FOR 190DT x ACTIVE TOUCHBAR WITH CYLINDER DOGGING: 4-1/2" MIN
- FOR 190DT x ACTIVE TOUCHBAR WITH EXIT ALARM, AE RETROFIT KIT OR KEY OVER-RIDE: 7-1/2" MIN.

3. IF DEVICE IS LONGER THAN "X", CUT THE DEVICE.

A) MARK DEVICE CHANNEL AND COVER TO LENGTH "X".

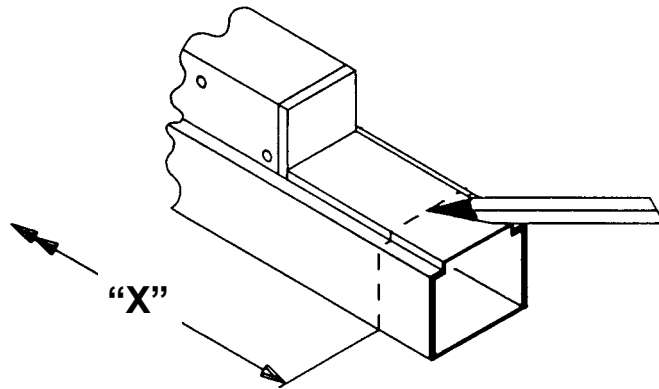

NOTE: BE SURE CHANNEL COVER IS PUSHED SNUG TO TOUCHBAR PRIOR TO MARKING OR CUTTING TO SIZE

B. CUT BOTH CHANNEL AND CHANNEL COVER TO MARKED DIMENSIONS AND REMOVE BURRS.

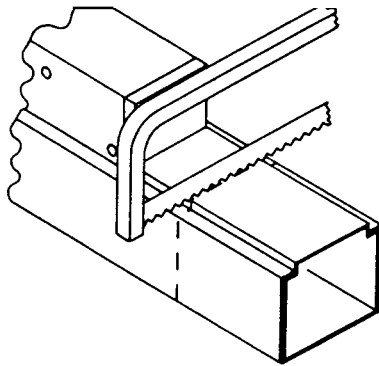

NOTE: FACTORY RECOMMENDS SAWING RATHER THAN GRIND CUT TO SIZE. GRINDING CAN DAMAGE THE FINISH OF THE DEVICE AND SAWING RESULTS IN LESS DAMAGE TO THE DEVICE'S FINISH.

4. DRILL MOUNTING HOLE.

REMOVE CHANNEL COVER AND DRILL 5/16" DIA. HOLE ON DEVICE REF \varnothing 5/16" FROM END OF CHANNEL.

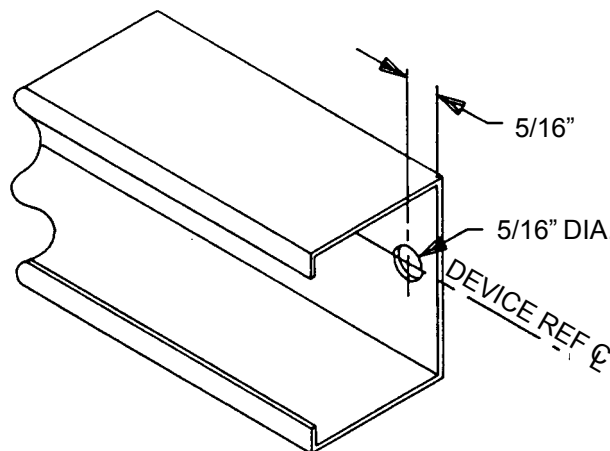

4 HARDWARE INSTALLATION

1. MOUNT DEVICE IN HOLE PREPARED IN DOOR USING A SEXBOLT, END CAP MOUNTING BRACKET, AND 1/4"-20x3/4" TPHMS SCREW AS SHOWN BELOW.
2. PREPARE HINGE SIDE OF DOOR FOR DEVICE MOUNTING BY:
 - A. LEVEL DEVICE.
 - B. MARK CENTER OF 5/16" DIA. HOLE AT END OF CHANNEL.
 - C. DRILL 9/32" DIA. HOLE THRU DOOR AND THEN DRILL 3/8" DIA. HOLE ON OPPOSITE SIDE OF DOOR USING 9/32" DIA. HOLE AS GUIDE (3/8" DIA. HOLE THRU FOR WOOD DOORS).
3. MOUNT HINGE SIDE OF DEVICE USING OTHER SEXBOLT, END CAP MOUNTING BRACKET AND 1/4"-20x3/4" TPHMS.
4. SLIDE CHANNEL COVER AND CHANNEL INSERT INTO DEVICE.
5. ATTACH CHANNEL END CAPS USING #8-32x3/8" UFPHMS w/NYLON PATCH SCREWS.

LHR SHOWN

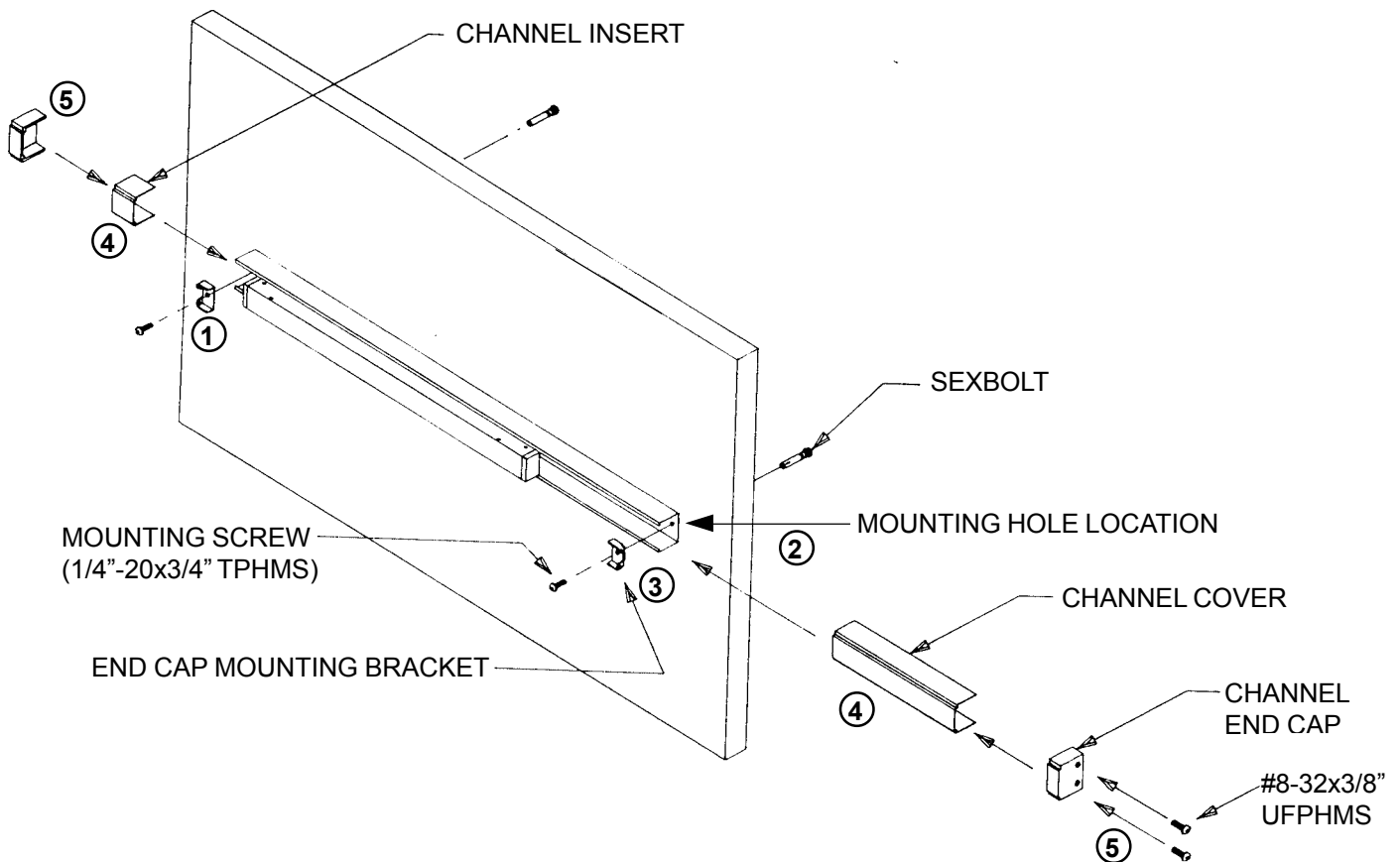

Customer Service

1-877-671-7011

www.allegion.com/us