



FALCON

D-4312 CRF-4023 & CR-4023

Mullion

Installation Instructions

5 CYLINDER REMOVABLE MULLION INSTALLATION

1. SCREW IN ADJUSTMENT SCREW ON THE TOP MULLION FITTING ASSEMBLY AS FAR AS POSSIBLE.
2. DROP BOTTOM OF MULLION ASSEMBLY OVER THE BOTTOM MULLION FITTING AND SWING MULLION ASSEMBLY INTO PLACE. IF MULLION ASSEMBLY WILL NOT SWING AND LOCK INTO PLACE, LOOK AT THE LOCATION OF THE PLUNGER WITH RESPECT TO THE LOCATOR ON THE CR UNIT.

A. IF THE PLUNGER IS ABOVE THE LOCATOR, THE MULLION ASSEMBLY IS TOO SHORT.

- 1) SWING THE MULLION ASSEMBLY AWAY FROM THE DOOR OPENING.
- 2) LOOSEN THE TOP MULLION FITTING ASSEMBLY MOUNTING SCREWS ENOUGH TO SLIDE IN THE ADJUSTMENT SHIM.
- 3) SLIDE THE ADJUSTMENT SHIM BETWEEN THE FRAME AND THE TOP MULLION FITTING BASE AND RE-TIGHTEN THE MOUNTING SCREWS.

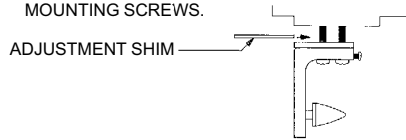

- 4) SWING THE MULLION ASSEMBLY BACK IN PLACE. THE MULLION ASSEMBLY SHOULD LOCK IN PLACE. IF NOT, REPEAT THE PROCESS UTILIZING ADDITIONAL ADJUSTMENT SHIMS.

B. IF THE PLUNGER IS BELOW THE LOCATOR, THE MULLION ASSEMBLY IS TOO LONG. RESIZE THE MULLION ASSEMBLY PER SECTION 4, STEPS 3 AND 4.



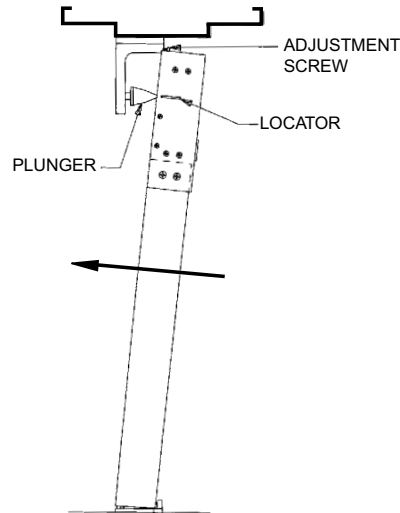







3. TURN THE KEY IN THE CYLINDER AND PULL THE MULLION ASSEMBLY AWAY. RE-INSTALL MULLION ASSEMBLY. REPEAT FOUR TO FIVE TIMES TO ENSURE PROPER FUNCTION.
4. ONCE THE MULLION ASSEMBLY IS IN PLACE, SLIDE A SCREWDRIVER THRU THE SLOT ABOVE THE CYLINDER AT THE TOP OF THE CR UNIT AND BACK THE ADJUSTMENT SCREW OUT OF THE TOP MULLION FITTING ASSEMBLY UNTIL THE MULLION ASSEMBLY IS HELD TIGHT.
5. TURN THE KEY IN THE CYLINDER. IF IT DOES NOT FREELY TURN, TURN THE ADJUSTMENT SCREW IN THE TOP MULLION FITTING ASSEMBLY IN BY **ONE-QUARTER** TURN AND REPEAT. IF KEY STILL DOES NOT FREELY TURN, REPEAT PROCESS UNTIL KEY FREELY TURNS AND MULLION ASSEMBLY CAN BE PULLED FROM OPENING.
6. INSERT MULLION ASSEMBLY BACK INTO OPENING.
7. FOR FIRE RATED MULLIONS, INSTALL STABILIZER BLOCKS, 2 PER DOOR, (SEE INSTRUCTION IN THE CENTER OF THIS BOOK, DT-4312).
8. INSTALL DEVICE PER DEVICE INSTALLATION INSTRUCTIONS.
9. FINISH (PAINT) MULLION MAKING SURE TO MASK THE WARNING STICKER TO PREVENT PAINTING OVER IT.

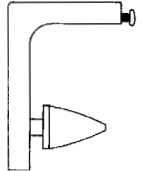
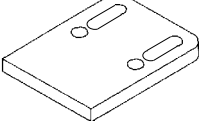

1 PARTS CHECK

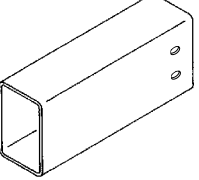
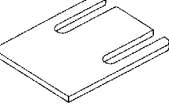
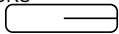
- 1) MAKE SURE THE CORRECT MULLION IS BEING USED AND THE APPROPRIATE RIM DEVICES ARE AVAILABLE.
- 2) MAKE SURE ALL NEEDED PARTS ARE ON HAND.

NOTE: LIST DOES NOT REFLECT ALL POSSIBLE APPLICATIONS

1. CR UNIT 	4. BOTTOM MULLION FITTING 	8. SCREW PACK 1/4"-20x3/4" UFPHMS (4 QTY)  CYLINDER NUT (1 QTY) 
2. TOP MULLION FITTING ASSY. 	5. TOP MULLION FITTING BASE 	CYLINDER RETAINER BRACKET (1 QTY)  1/4"-20x2" PPHMS (4 QTY) 
3. MULLION 	6. ADJUSTMENT SHIM 	3/8" STEEL ANCHORS  3/8"-16x1-1/4" FPHMS (2 QTY) 
7. MORTISE CYLINDER 1-1/4" MORTISE CYLINDER REQUIRED WITH STANDARD "A" CAM (3/4" LONG, 5/16" WIDE) NOTE: 1-1/2" AND LONGER CYLINDERS REQUIRE BLOCKING RINGS SUPPLIED BY OTHERS		STABILIZER BLOCKS (4 QTY - CRF-4023 ONLY)  1/4"-20x1-1/4" FPHMS (8 QTY - CRF-4023 ONLY) 



Customer Service

1-877-671-7011 www.allegion.com/us

© Allegion 2014
Printed in U.S.A.
D-4312 Rev. 01/14-b

2 DOOR OPENING LAYOUT

1. DOOR SHOULD BE FITTED AND HUNG INSIDE FRAME.
2. CHECK SQUARENESS OF FRAME AT CENTER OF OPENING WITH RESPECT TO THE DOORS. IF FRAME IS NOT SQUARE, IT MAY BE NECESSARY TO ADJUST THE FRAME, OR TO SHIM THE TOP FITTING WITH A SHIM, TO PROVIDE A SQUARED FIT TO GET PROPER MULLION ENGAGEMENT.
3. MARK CENTERLINE OF OPENING ON TOP FRAME AND ON FLOOR.

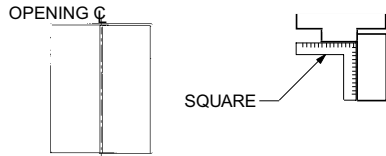

4. POSITION THE BOTTOM MULLION FITTING AS SHOWN BELOW. MARK THE C OF THE TWO COUNTERSUNK MOUNTING HOLES ON THE FLOOR.

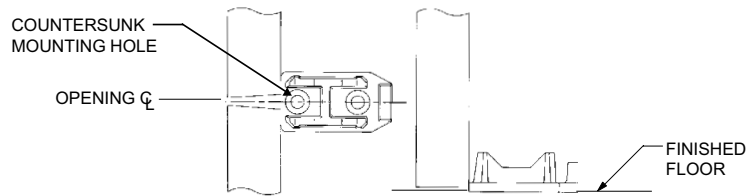

3 MULLION FITTING INSTALLATION

1. MARK THE TOP OF THE FRAME PER THE DRILLING TEMPLATE FROM THE CENTER OF THIS BOOK. CENTER PUNCH, DRILL AND TAP MARKED HOLES THRU BOTH FRAME SKIN AND REINFORCEMENT.

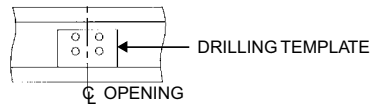

2. MOUNT TOP MULLION FITTING ASSEMBLY AND TOP MULLION FITTING BASE ON FRAME USING FOUR 1/4"-20x2" PPHMS.

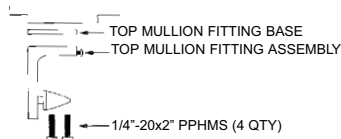

3. PREPARE FINISHED FLOOR TO RECEIVE 3/8" STEEL ANCHORS AT LOCATIONS MARKED IN 2, STEP 4.
4. INSTALL BOTTOM MULLION FITTING ON FLOOR.

4 MULLION PREPARATION

1. USING CYLINDER NUT AND CYLINDER RETAINER BRACKET, INSTALL MORTISE CYLINDER IN CR UNIT. IT MAY BE NECESSARY TO PUSH THE SPRING LOADED LOCKING PLATE IN THE CR UNIT UP TO SCREW ON THE CYLINDER NUT. AFTER INSTALLING THE CYLINDER, INSERT AND TURN KEY TO CHECK FUNCTION OF THE CR UNIT (SEE BELOW).

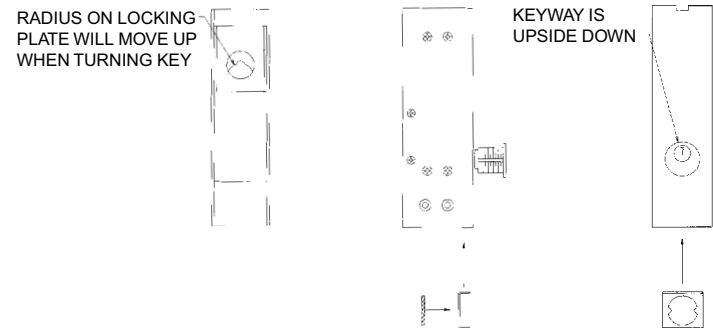

2. ASSEMBLE THE CR UNIT TO THE MULLION WITH FOUR 1/4"-20x3/4" UFPHMS.

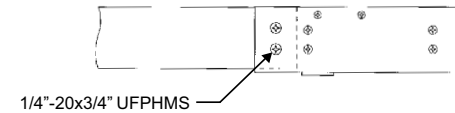

3. MEASURE THE HEIGHT OF THE DOOR OPENING AS SHOWN BELOW AT THE CENTERLINE OF THE DOOR OPENING. RECORD MEASUREMENT ("Y") HERE: _____

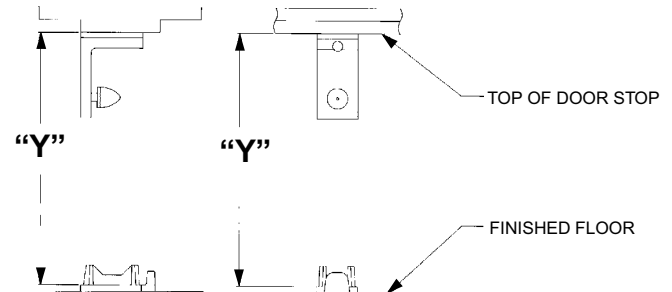

4. MARK MULLION AND CR UNIT ASSEMBLY ON ALL SIDES OF THE MULLION BODY TO THE MEASUREMENT TAKEN IN STEP 5 MINUS 5/8". THEN CUT THE MULLION ASSEMBLY TO THE MARKED LENGTH.

$$"X" = "Y" - 5/8"$$

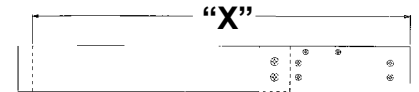

CRF-4023 AND CR-4023 MULLION TOP MULLION FITTING ASSEMBLY DRILLING TEMPLATE AND STABILIZER BLOCK DOOR PREPARATION

STABILIZER BLOCK DOOR PREPARATION

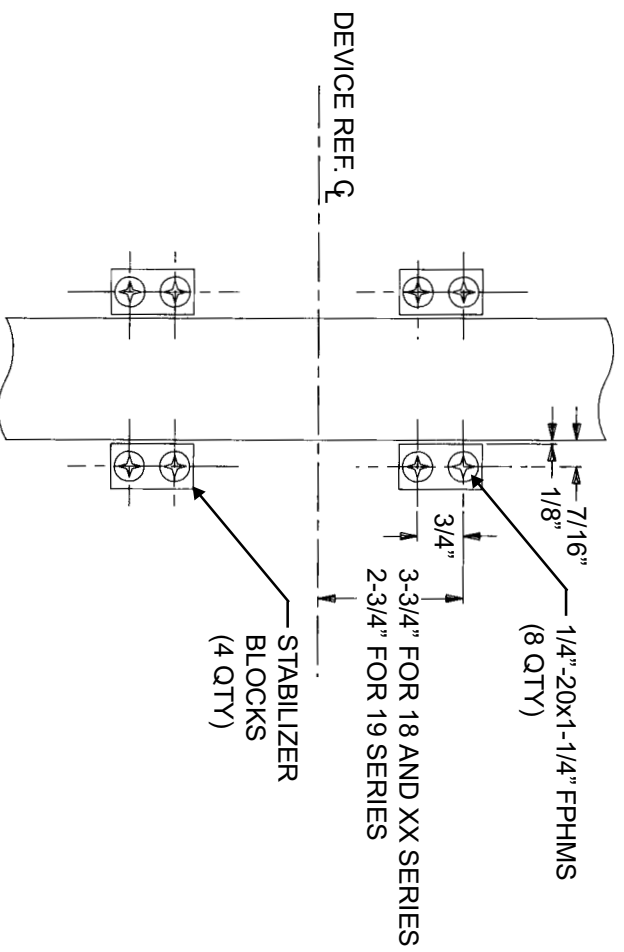

TOP MULLION FITTING ASSEMBLY DRILLING TEMPLATE

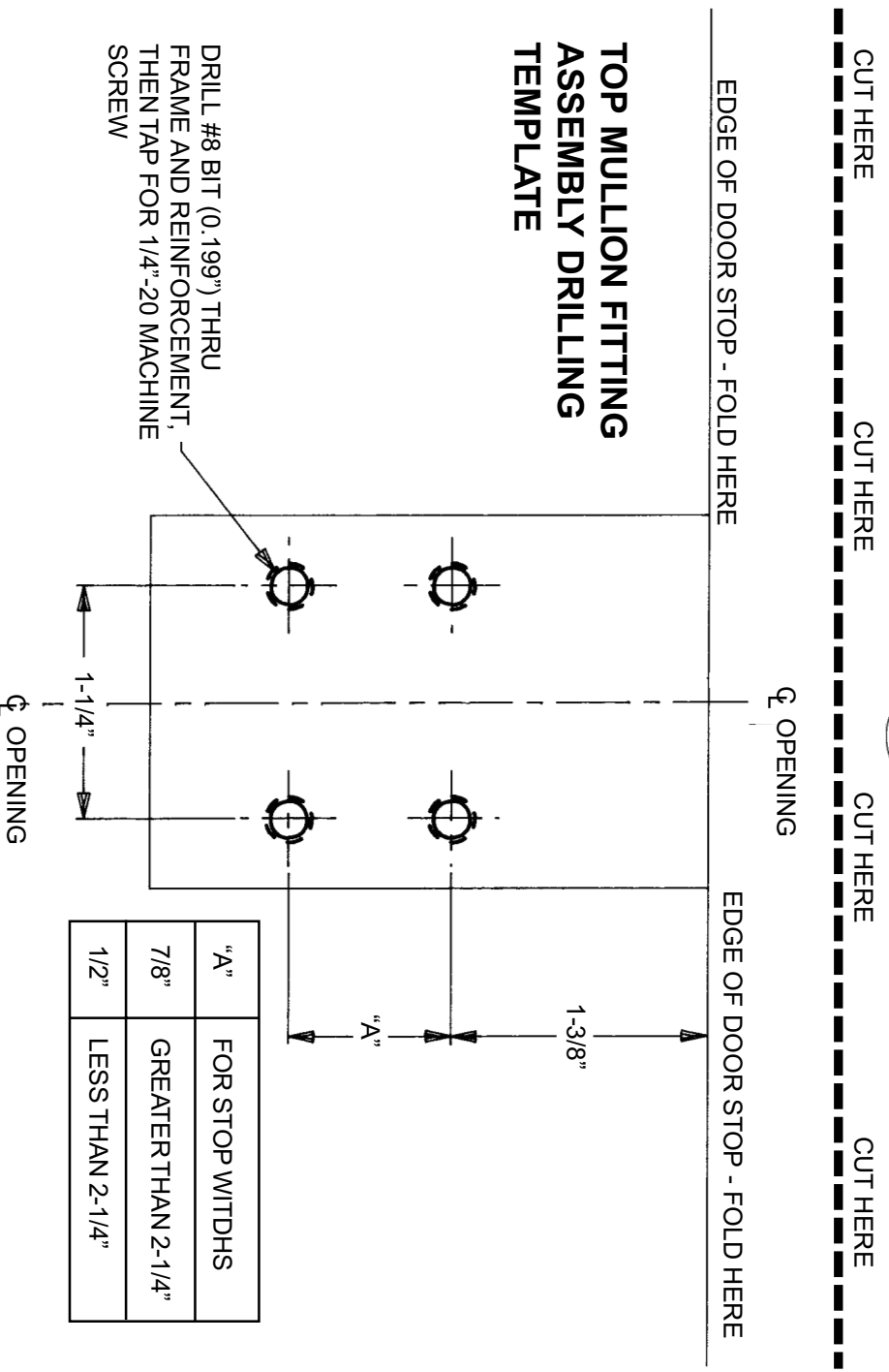

"A"	FOR STOP WITDHS
7/8"	GREATER THAN 2-1/4"
1/2"	LESS THAN 2-1/4"