



Q513-064

# D151/151F (UL)

# D251/251F (UL)

## FALCON®

Double Thumbturn Deadbolt  
Cerrojo de Pasador con Mariposa Doble  
Pêne Dormant avec Barrette Tourante Double

Installation Instructions  
Instrucciones de instalación  
Notice d'installation

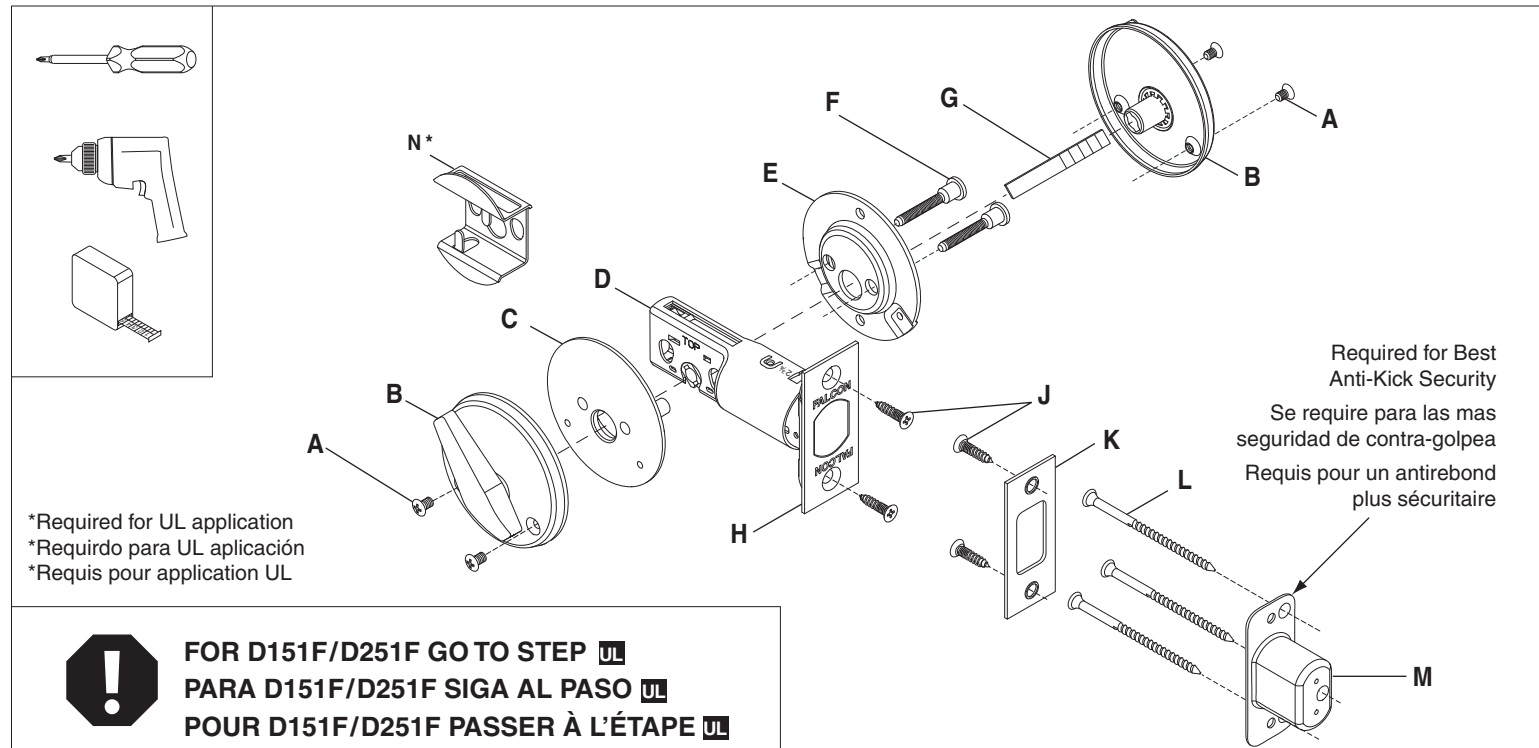

\*Required for UL application  
\*Requirido para UL aplicación  
\*Requis pour application UL



**FOR D151F/D251F GO TO STEP 1**  
**PARA D151F/D251F SIGA AL PASO 1**  
**POUR D151F/D251F PASSER À L'ÉTAPE 1**

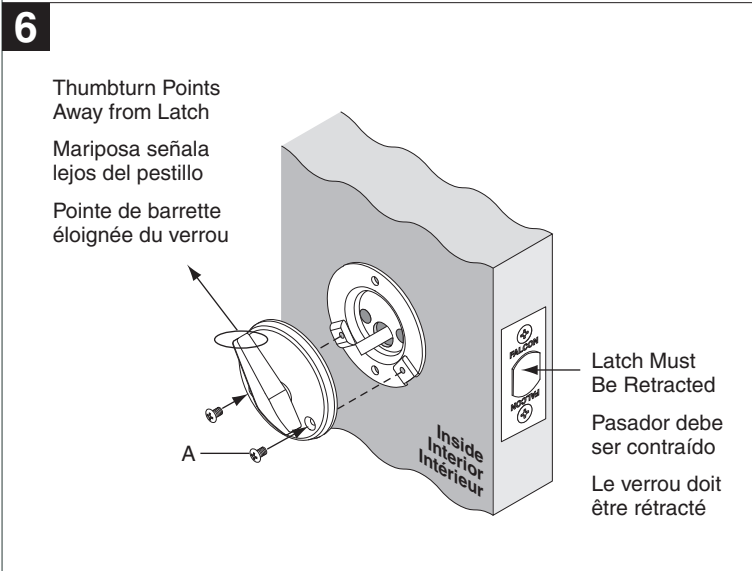
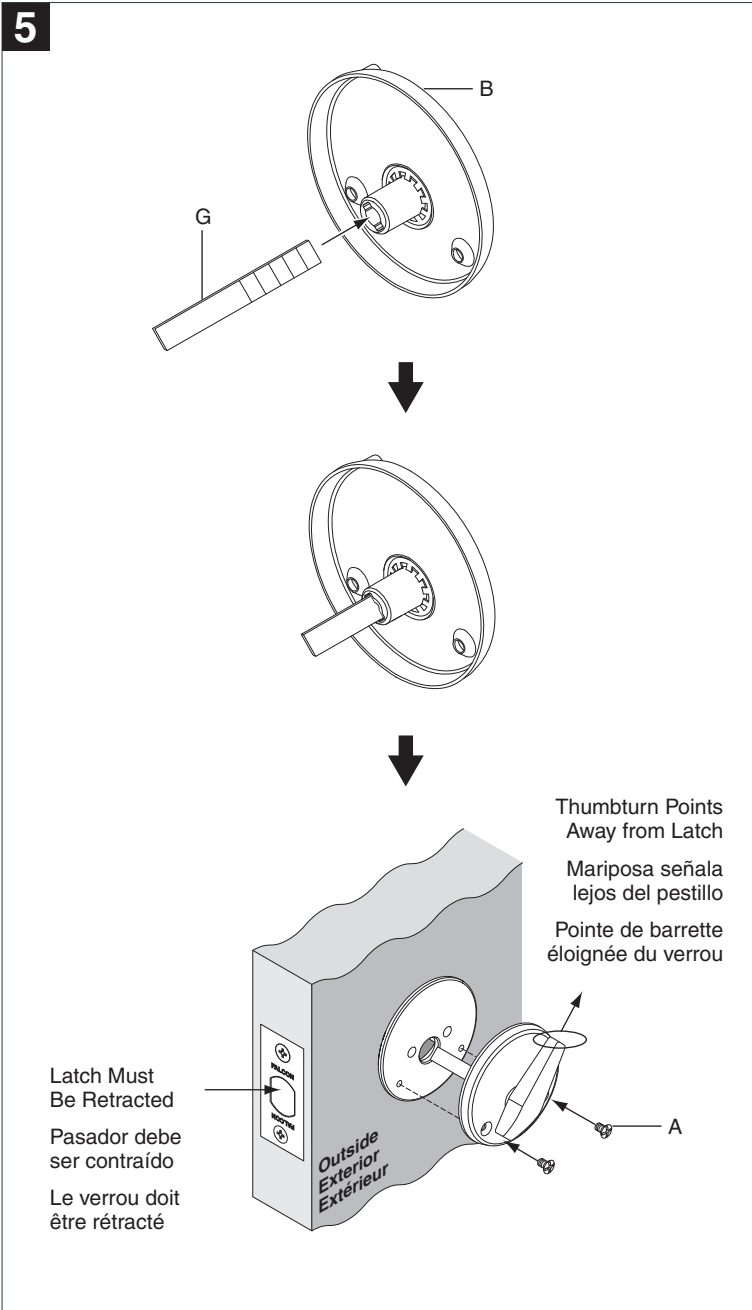
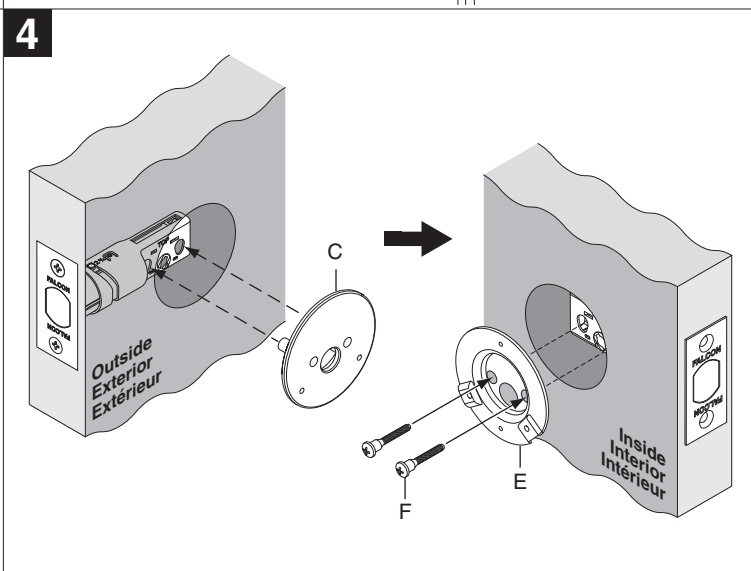
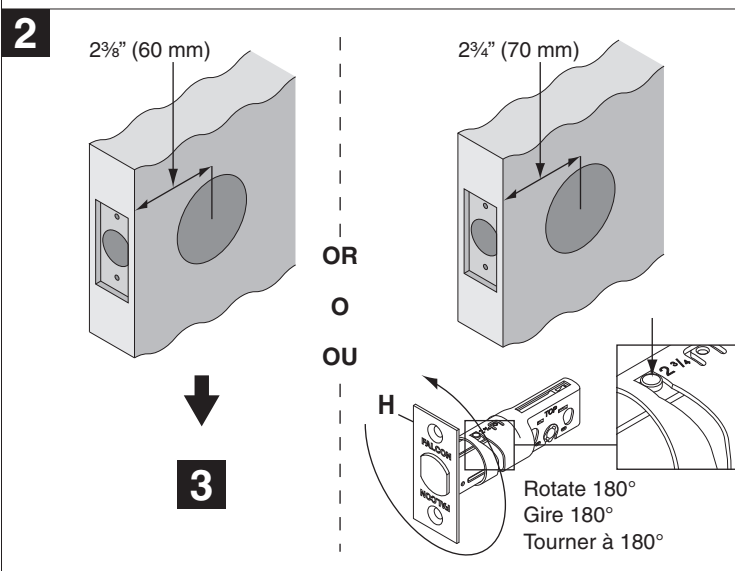
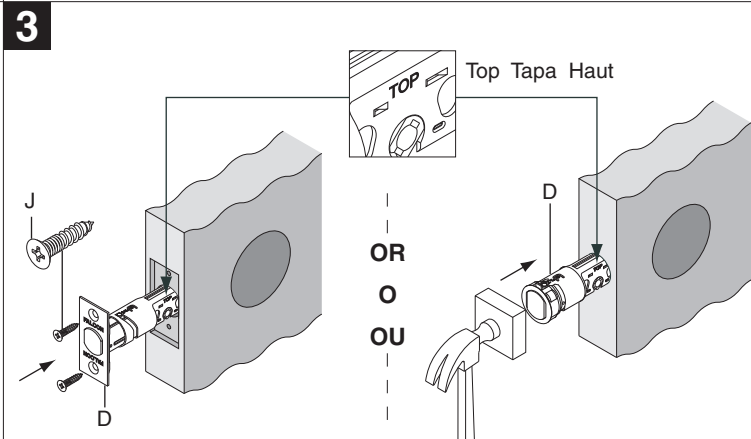
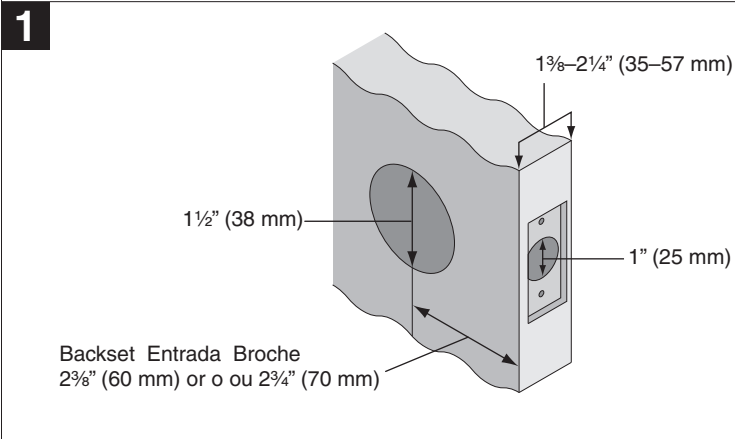

Customer Service Servicio al cliente Service à la clientèle  
1-877-671-7011 www.allegion.com/us

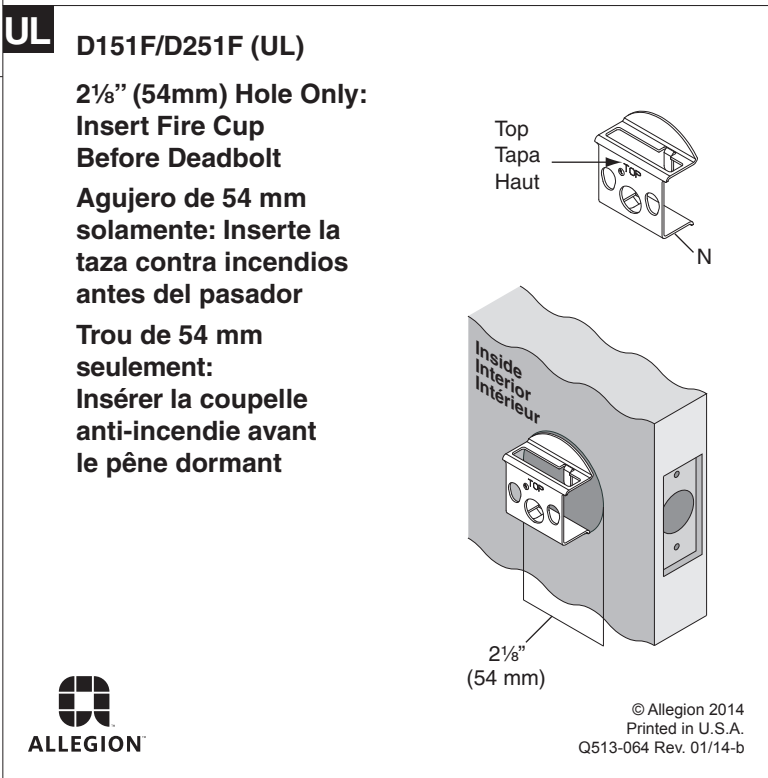
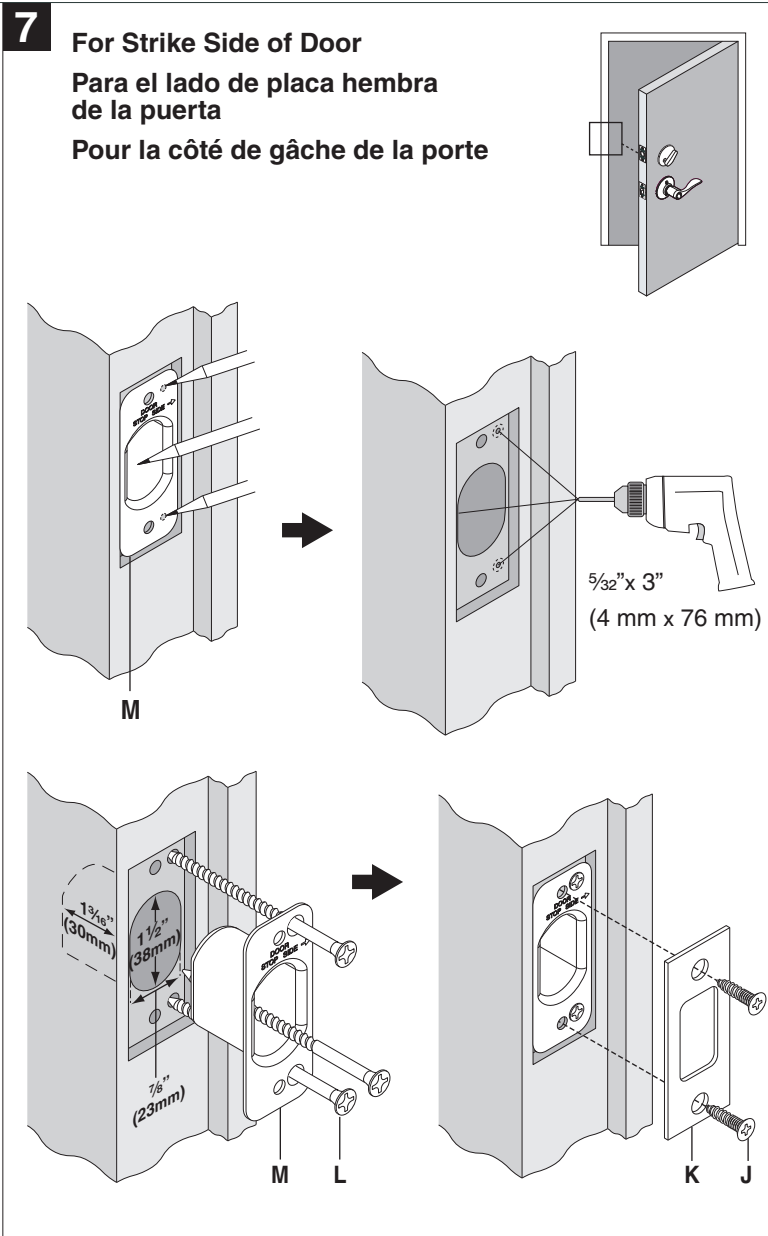

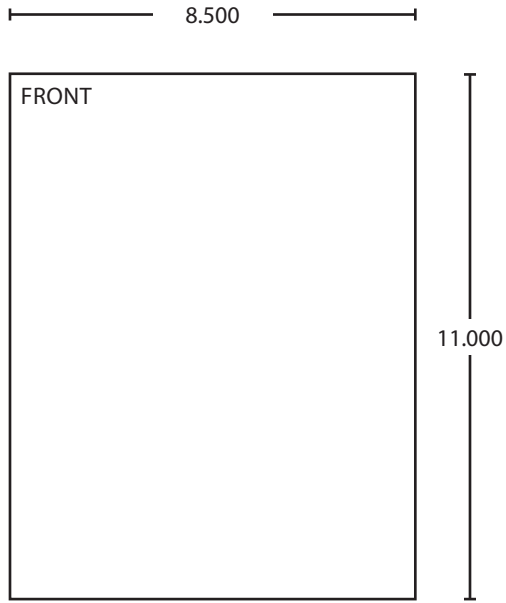

BEGINNING SHEET

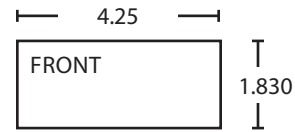

FOLDED SHEET

Additional Notes:
1. None

Revision History						Revision Description:					
A	B	C	D	E	F	B > Revised artwork					
1437											
Material White Paper						Edited By		Approved By		EC Number	Release Date
						D. Spence		M. Sasso		043528	01-01-14
Notes 1. printed two sides 2. printed black 3. tolerance ± .13 4. printed in country may vary 5. drawings not to scale						Title Sheet, Instruction D151-251F					
						Creation Date 01-15-14		Number Q513-064			Revision B
						Created By D. Spence		Activity 3899 Hancock Expwy Security, CO 80911		© Allegion 2014	
						Software: InDesign CS6					