

FERME-PORTE SÉRIE SC 71
INSTRUCTIONS D'INSTALLATION
Modèles avec bras Spring-N-Stop
& Spring-N-Stop/avec retenue

SC71 (1-6 Adj.)

SC 71 SERIES DOOR CLOSER
INSTALLATION INSTRUCTION
Spring-N-Stop & Spring-N-Stop/Hold Open Arm Models

SC71 (1-6 Adj.)

CERRADOR DE PUERTA SERIE SC 71
INSTRUCCIONES DE INSTALACIÓN

Modelos con brazo Spring-N-Stop
& Spring-N-Stop/con retención

SC71 (1-6 Adj.)

Parallel Arm Closer mounted on push side of door.
Installation (Opposite of the hinge side)

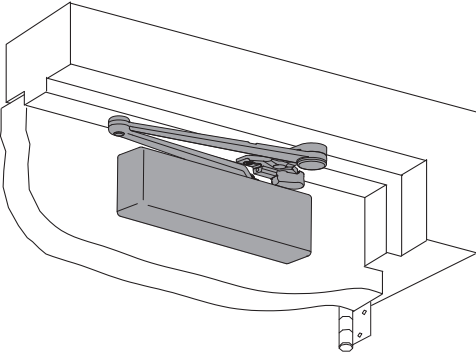

Installation "bras parallèle" Ferme-porte installé sur le côté à pousser de la porte. (À l'opposé du côté de la charnière)
 Instalación "brazo paralelo" Cerrador montado a lado del empuje de la puerta. (Opuesto al lado del gozne)

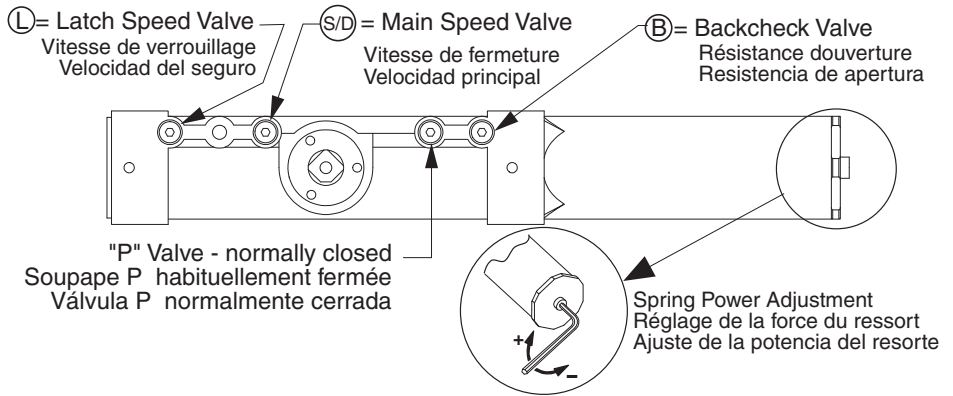

FASTENERS		DOOR / FRAME	DRILL-SIZES
ARM SHOE	#14 wood	WOOD	1/8"
	1/4-20 machine	METAL	drill: #7 tap: 1/4-20
CLOSER BODY	#14 wood	WOOD	1/8"
	1/4-20 machine	METAL	drill: #7 tap: 1/4-20
EITHER	Thru-bolt	ALL	3/8"
FIFTH-HOLE SPACER	#14 wood	WOOD	1/8"
	1/4-20 machine	METAL	drill: #7 tap: 1/4-20
ARM ATTACHMENT SCREW ARM ATTACHMENT LOCK WASHER			
COVER SCREW COVER PLUG			

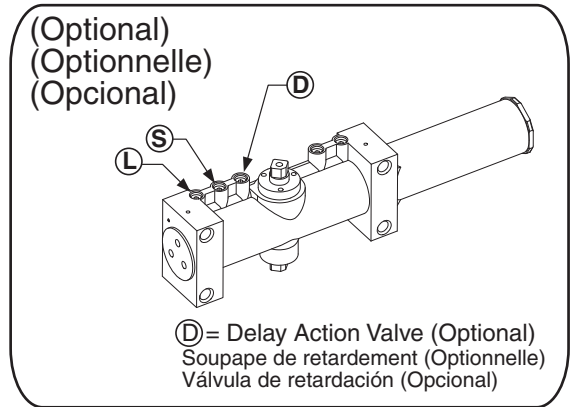

CAUTION
 IMPROPER INSTALLATION OR REGULATION MAY RESULT IN PERSONAL INJURY OR PROPERTY DAMAGE. FOLLOW ALL INSTRUCTIONS CAREFULLY. FOR QUESTIONS, CALL FALCON AT 1-877-671-7011

ADVERTENCIA
 Una instalación o un ajuste incorrectos pueden resultar en daño personal o material. Siga bien todas las instrucciones. para más informaciones, lláma a fon al 1-877-671-7011

DANGER
 Une installation ou un réglage inadéquats peuvent entraîner des blessures ou des dommages. Veuillez suivre toutes les instructions avec soin. Pour plus de renseignements, composez le 1-877-671-7011

Customer Service **Servicio al cliente** **Service à la clientèle**
 1-877-671-7011 www.allegion.com/us

- 1. Door and Frame Preparation** A. Choose degree of door opening B. Drill per screw chart. (See front page)
 Préparation de la porte et du cadre A.Sélectionnez le degré d'ouverture désiré B.Percez selon les indications du tableau (voir la page frontispice)
 Preparación de la puerta y del cuadro A.Elija el grado de apertura de la puerta B.Barrene según el gráfico (Vea la página de la cubierta)

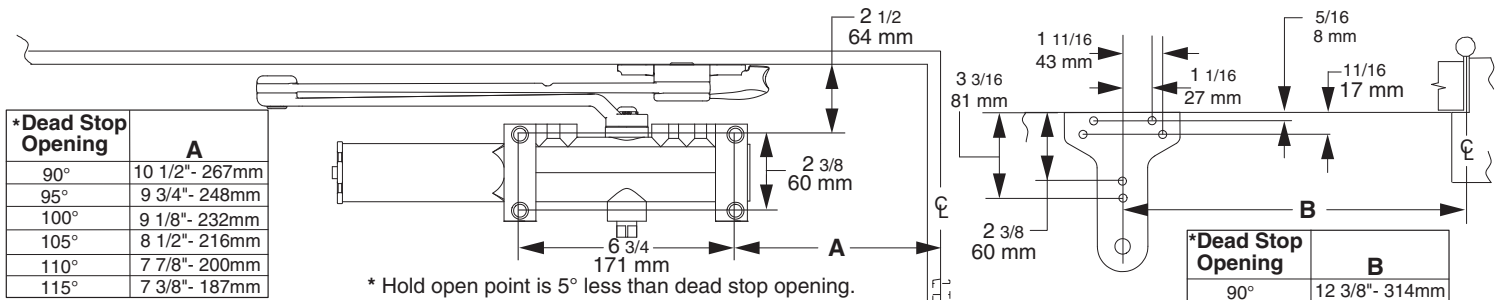

*Dead Stop Opening	A
90°	10 1/2" - 267mm
95°	9 3/4" - 248mm
100°	9 1/8" - 232mm
105°	8 1/2" - 216mm
110°	7 7/8" - 200mm
115°	7 3/8" - 187mm

*Dead Stop Opening	B
90°	12 3/8" - 314mm
95°	11 5/8" - 295mm
100°	11" - 279mm
105°	10 3/8" - 264mm
110°	9 3/4" - 248mm
115°	9 1/4" - 235mm

* Hold open point is 5° less than dead stop opening.

RIGHT HAND DOOR ILLUSTRATED.

Same dimensions apply for Left Hand Door measured from center line of hinge.
 PORTE MAIN DROITE ILLUSTRÉE. Les mêmes dimensions s'appliquent pour une porte main gauche, mesurées à partir du centre de la charnière.
 PUERTA MANO DERECHA ILUSTRADA. Las mismas dimensiones se aplican para puertas de mano izquierda, medidas a partir de la línea central de la bisagra.

- 2. Determine door width, adjust spring power to match chart.**

Mesurez la largeur de la porte.
 Réglez le ressort selon les indications du tableau.
 Determina la anchura de la puerta. Ajuste la potencia del resorte según lo indicado en el gráfico.

POWER ADJUSTMENT RÉGLER LA PUISSANCE AJUSTE DE POTENCIA	
	0
32" - 815mm	+ 5
36" - 915mm	+ 9
42" - 1050mm	+ 15
48" - 1220mm	+ 21

* Door closer is shipped with +9 turns.
 Ferme-porte expédié avec +9 révolutions
 Cerrador mandado con +9 vueltas

- 3. Install closer onto door.**
 Installez le ferme-porte sur la porte.
 Monte el cerrador en la puerta.

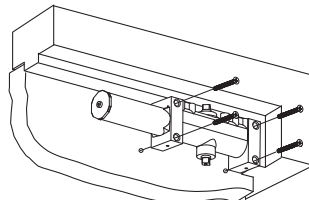

Valves UP for Right hand door. (Shown)

Valves DOWN for Left hand door.

Soupapes vers le HAUT pour porte main droite (illustrée)
 Soupapes vers le BAS pour porte main gauche
 Válvulas ARRIBA para puerta mano derecha (ilustrada)
 Válvulas ABAJO para puerta mano izquierda

Spring Power faces away from the hinge edge.

Force du ressort fait face à l'opposé du bord de la charnière.
 Potencia del resorte cara opuesta al borde del gozne.

- 4. Install arm & shoe assembly onto frame.**
 Installez l'assemblage du bras et de la console sur le cadre. Installe el ensamblaje del brazo y de la zapata en el cuadro.

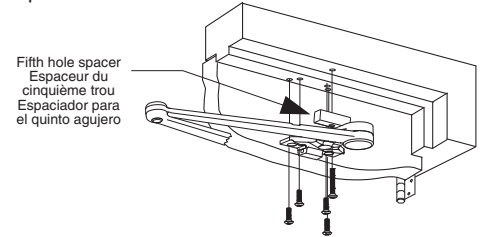

HOLD OPEN ARM: To engage or disengage hold open feature, turn control handle one-quarter (1/4) turn.

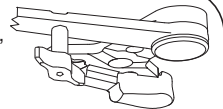

BRAS DE RETENUE: Pour engager ou désengager le mécanisme de retenue, tournez la manette de contrôle d'un quart (1/4) de tour.

BRAZO DE RETENCIÓN: Para embragar o desembragar la característica de retención, dar un cuarto de vuelta (1/4) al cabo.

- 5. Securely attach spring block to shoe.** (Right hand shown)

Fixez solidement le bloc ressort au sabot (main droite illustrée)

Sujeta seguramente el bloque resorte a la zapata (Mano derecha ilustrada)

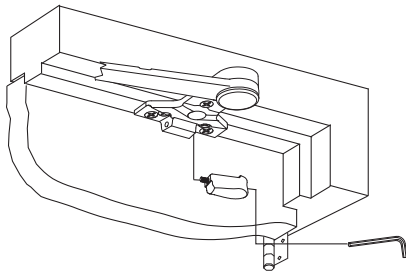

- 6. Attach main arm to closer.**
 Attachez le bras principal au ferme-porte.
 Coloque el brazo principal al cerrador.

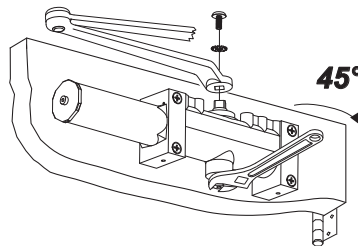

- 8. Attach cover with screws and insert cover plugs.**
 Fixez le couvercle avec les vis et insérez les bouchons de couvercle.
 Sujeta la tapa con las tuercas e inserte los tapones de tapa.

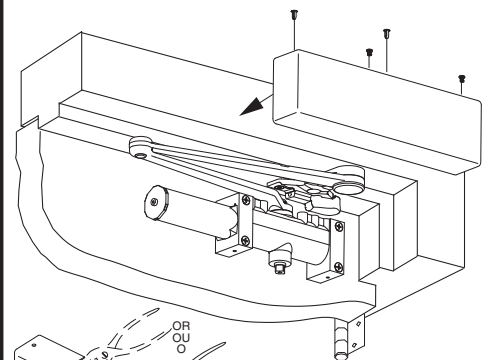

- 7. Adjustment Instructions**
 Instructions de réglage
 Instrucciones de ajuste

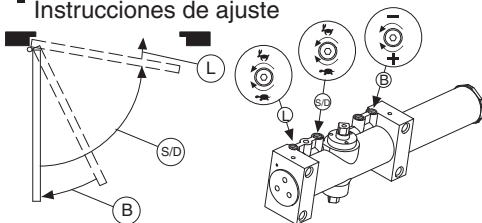

Optional Delay Action

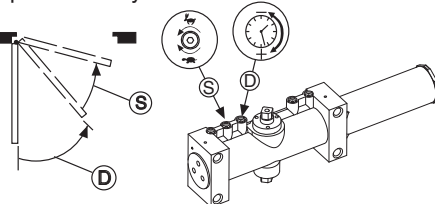

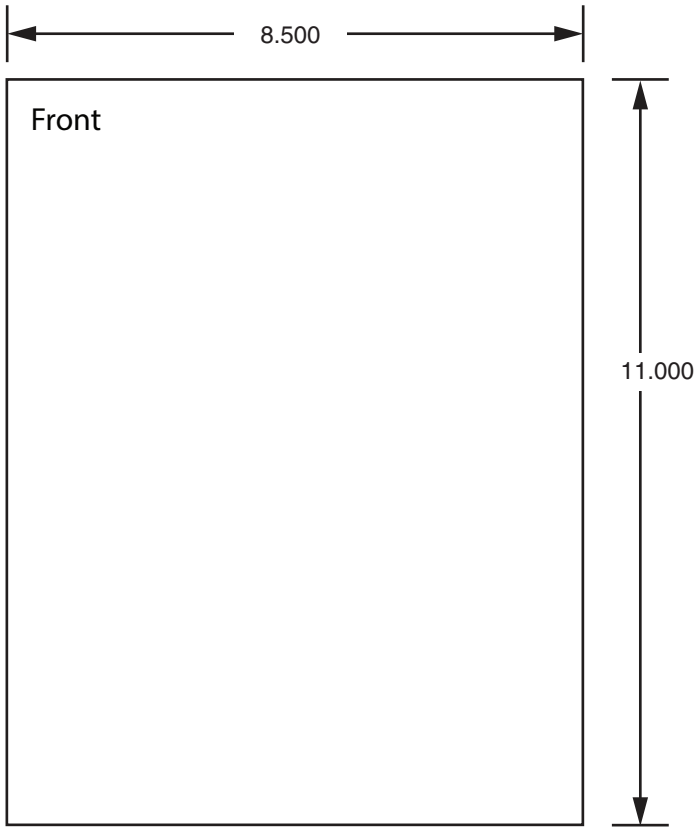

Beginning Sheet

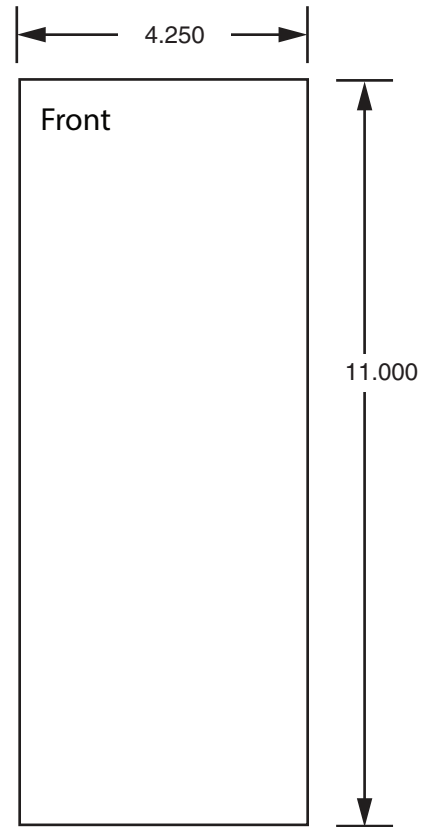

Final Size

Additional Notes:
None

Revision History						Revision Description:					
D	E	F	G	H	J	D > Revised Artwork					
047232	EC #	EC #	EC #	EC #	EC #						
Material						Edited By		Approved By		EC Number	Release Date
White Paper						D. Myers		M. Sasso		047232	02-27-14
Notes						Title					
<ol style="list-style-type: none"> printed two sides printed black tolerance: ± .13 printed in country may vary drawings to not scale 						SC71 Series Spring N Stop Instruction Sheet					
Creation Date		Number				Revision					
04-27-10		43163				D					
Created By		Activity									
N/A		3899 Hancock Expwy									
Software: Illustrator CS6		Security, CO 80911						© 2014 Allegion			