

For use with: 3CB1 suffixed TW4-CON, and TW8-CON

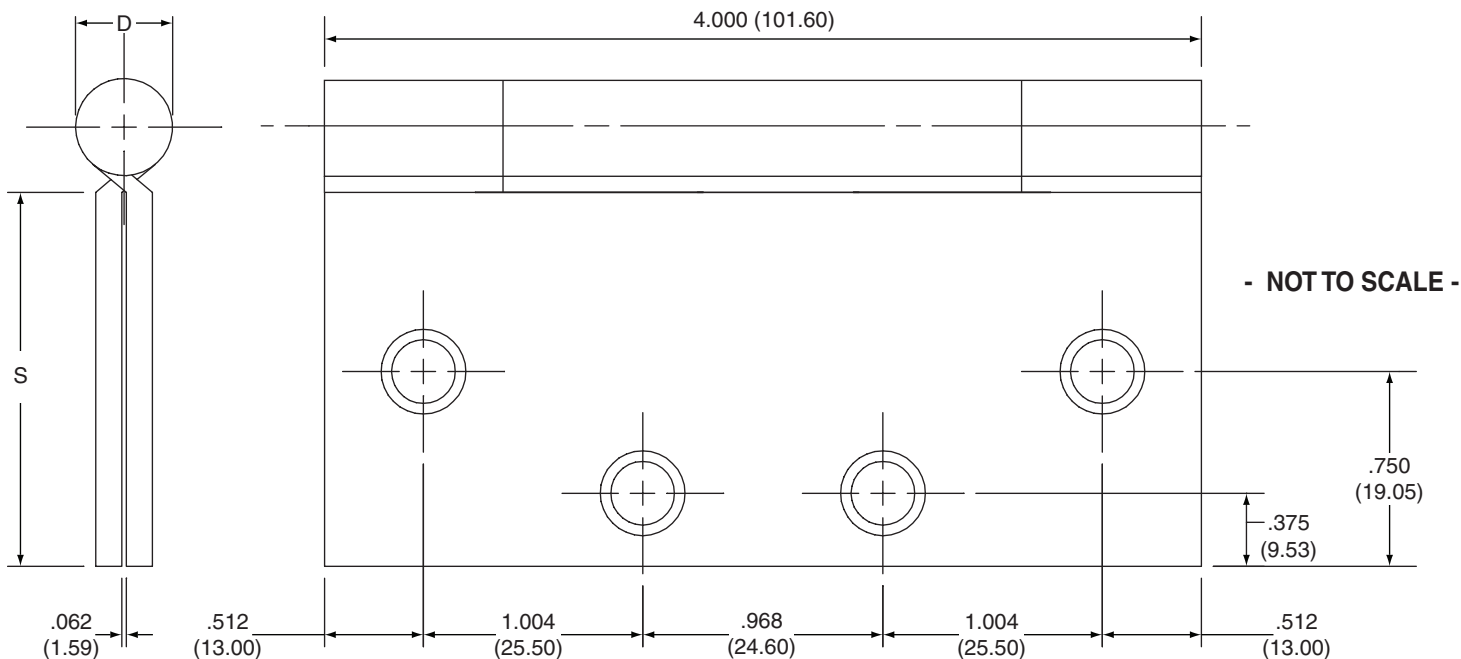

TW4 and TW8

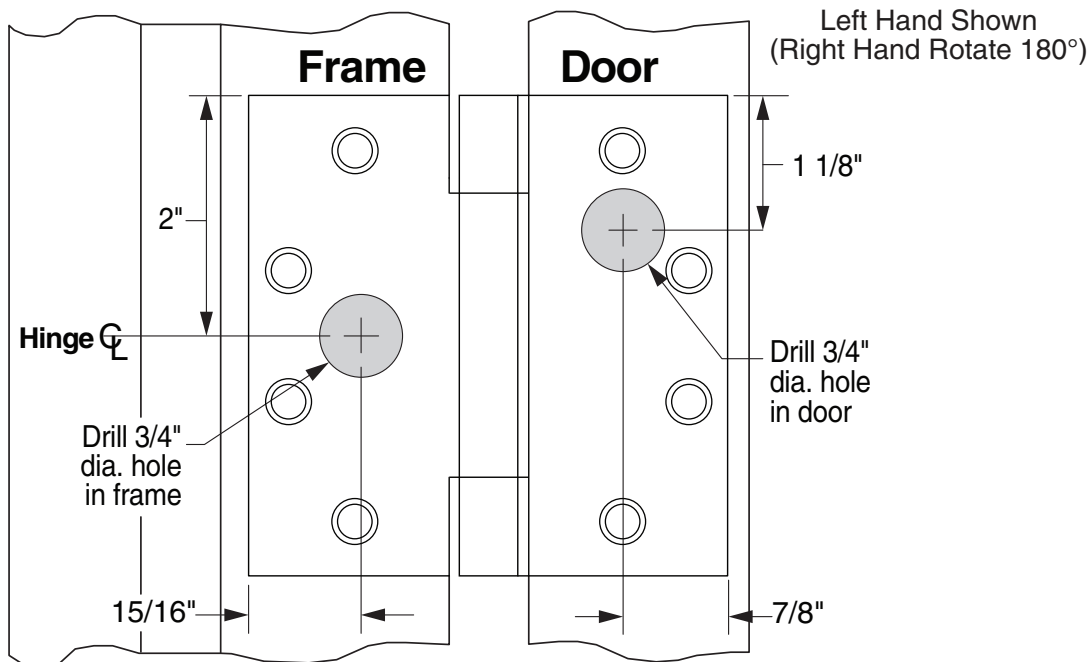

Hinge Model	Hinge Weight	Metal Gauge	(D) Knuckle Diameter	(S) Distance From Edge of Leaf to Swage Line
				4 x 4 (101.60 x 101.60)
3CB1	Standard	.130 (3.30)	.609 (15.48)	1.625 (41.28)

Machine Screw Size: 12-24 x 1/2" F.H.
Wood Screw Size: #12 x 1 1/4" F.H.

- Notes:**
1. Round Corners (RC) application will have 1/4" (6.35) and 5/8" (15.88) radius corners, but will conform to template as shown above the other radius corners.
 2. Hospital Tip (HT) and Wide Throw (WT) applications will conform to template as shown above.

Customer Service

1-877-671-7011

www.allegion.com/us

IVES HINGES ARE MADE IN SIZE, GAUGE AND WITH SCREW HOLES LOCATED TO CONFORM TO ANSI - A156.7.

IVES

3 KNUCKLE 4" ELECTRIC FULL MORTISE HINGE TEMPLATE



ALLEGION

© 2020 Allegion
INST.4-3KEHG
Rev. 08/20-a

Note: Dimensions in () are millimeters

Template Number **INST.4-3KEHG_A**