

Study the picture to the right and determine which instructions and template are to be used.

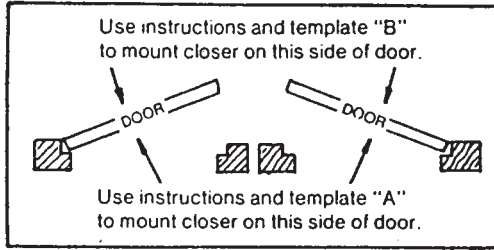

INSTRUCTION "A"

2. Make sure door swings freely. Lubricate hinges if necessary.
3. Cut out template "A" and place on hinge side of door frame. Mark hole centers on door frame for six (6) screws and drill 1/8" pilot holes.
4. Facing door from the closer side; if hinges are on the right side, large bracket should be installed with side having the eight (8) slots surrounding the large hole in the DOWN position. If hinges are on the left side, the slots should be in the UP position. Install bracket using six (6) #10 x 7/8" screws. Soap can be applied to the screws for easier installation.
5. Slide hold open bracket on closer rod with tab toward closer tube.
6. Assemble two (2) plastic bushings to the large holes in the large bracket. (See Fig. 2)
7. Place spring in large bracket with hook end toward the eight (8) slots in bracket. (See Fig. 2)
8. Insert hub from the BOTTOM, through the spring, and through the top hole of the large bracket. NOTE: Align internal spring hook with "U" slot in hub.
9. Place steel spacer over top of hub.
10. Slide closer rod into hub. Align large groove in closer rod with small hole in top of hub and insert short connecting pin.

Temporarily attach small bracket to the FRONT hole in closer tube using long connecting pin.
12. With door closed, twist large spring and disengage from slots in large bracket. Swing closer tube to door until small bracket touches door. Align small groove in closer rod with rear of tube. NOTE: This setting will give a 100 degree door opening. For 90 degree opening, locate small groove approximately 9/32" from REAR end of tube.
13. With closer tube level (horizontal position), mark the rear hole in the small bracket and remove from closer tube. Realign small bracket and mark the front hole. Drill 2-1/8" pilot holes and install small bracket using two (2) #10x7/8" screws. CAUTION: DO NOT DRILL THROUGH DOOR.
14. With door closed, twist large spring and position closer tube 90 degrees to door. Engage hook end of large spring in closest slot. Push closer tube to door and connect to small bracket with long connecting pin.

CAUTION: FOLLOWING STEP NO. 14 THE CLOSER TUBE WILL SWING AWAY FROM THE DOOR WHENEVER THE LONG CONNECTING PIN IN THE SMALL BRACKET IS REMOVED. WHEN REMOVING LONG CONNECTING PIN FOR ADJUSTMENTS, GRASP THE CLOSER TUBE FIRMLY AND KEEP AWAY FROM ITS PATH.

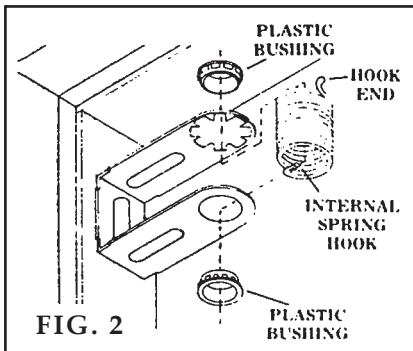
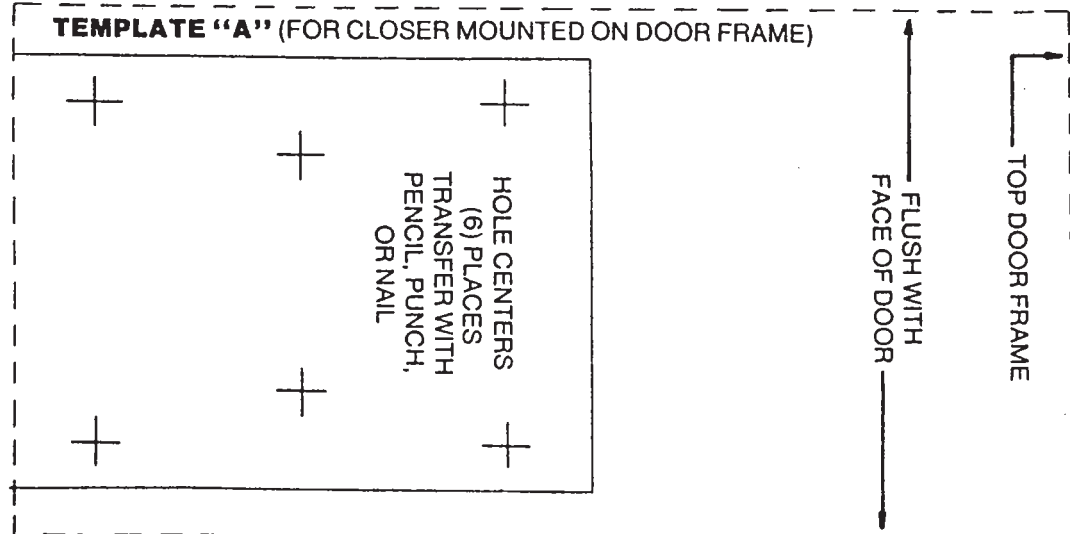

FIG. 2



CLOSER ADJUSTMENTS

A. SPEED ADJUSTMENT

Rotate air adjusting screw at end of closer tube: Clockwise for slower, counter clockwise for faster.

B. LESS LATCHING FORCE

Disconnect closer tube from small bracket and repeat step 14. Position closer tube 45 degrees from door (rather than 90 degrees) and reconnect.

C. MORE LATCHING FORCE

Disconnect closer tube from small bracket. Hold spring hub in place, remove short connecting pin and pull closer rod out of spring hub. Disengage hook end of large spring and rotate spring hub to next slot (or two slots for extra heavy latching force.)

(NOTE: if required, a wrench (1 1/16") can be used to rotate spring hub to aid in assembly).

CAUTION: DO NOT ENGAGE SPRING MORE THAN TWO SLOTS BEYOND 90 DEGREES AS PERMANENT CLOSER DAMAGE MAY RESULT.

Reassemble closer rod to spring hub and insert short connecting pin. Reconnect closer to small bracket.

D. SNAP ACTION LATCHING

To reduce the snap action latching speed (the last few inches of travel) for smoother, more quiet operation, remove the long connecting pin from small bracket and relocate in REAR hole of closer tube.

Periodically lubricate bearing surfaces at top and bottom of large bracket and closer rod as necessary.

For future reference; fold these instructions, place them in back of large bracket, and slide cover over large bracket.

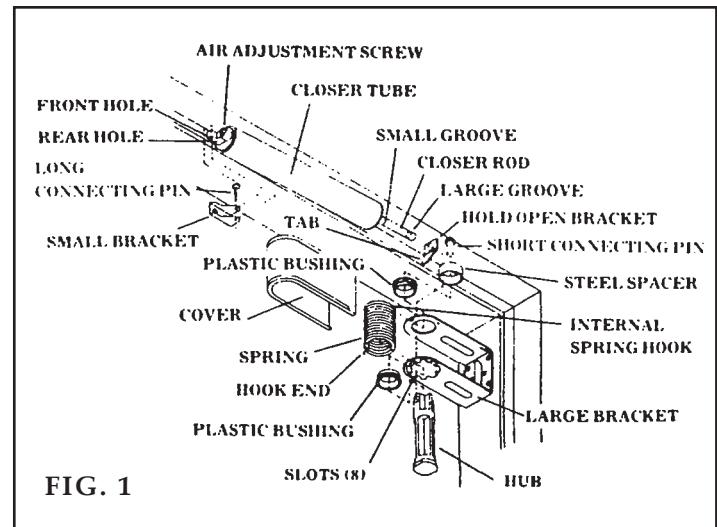

FIG. 1

927 - HEAVY DUTY DOOR CLOSER - PART 2

INSTRUCTION "B"

1. Allow a minimum of 6 inches clearance from center line of hinge pin to wall.
 2. Make sure door swings freely. Lubricate hinges if necessary.
 3. Cut out template "B" and place on hinge side of door with edge of template even with edge of door and top of template flush with top of door. Mark hole centers and drill six (6) 1/8" pilot holes. CAUTION: DO NOT DRILL THROUGH DOOR.
 4. Facing door from the closer side; if hinges are on the right side, large bracket should be installed with side having the eight (8) slots surrounding the large hole in the DOWN position. If the hinges are on the left side, the slots should be in the UP position. Install bracket using six (6) #10 x 7/8" screws. Soap can be applied to the screws for easier installation.
 5. Slide hold-open bracket on closer rod with tab toward closer tube.
 6. Assemble two (2) plastic bushings to the large holes in the large bracket (See Fig. 2)
 7. Place spring in large bracket with hook end toward the eight (8) slots in bracket. (See Fig. 2)
 8. Insert hub from the BOTTOM, through the spring, and through the top hole of the large bracket. NOTE: Align internal spring hook with "U" slot in hub.
 9. Place steel spacer over top of hub.
 10. Slide closer rod into hub. Align large groove in closer rod with small hole in top of hub and insert short connecting pin.
 11. Temporarily attach small bracket to the FRONT hole in closer tube using long connecting pin.
 12. With door closed, twist large spring and disengage from slots in large bracket. Swing closer tube to door until small bracket touches door frame. Align small groove in closer rod with rear of tube. NOTE: This setting will give 100 degree opening. For 90 degree opening, locate small groove approximately 9/16" from REAR end of tube.
 13. With closer tube level (horizontal position), mark the rear hole in the small bracket and remove from closer tube. Realign small bracket and mark the front hole. Drill 2-1/8" pilot holes and install small bracket using two (2) #10x7/8" screws.
- With door closed, twist large spring and position closer tube 90 degrees to door. Engage hook end of large spring in closest slot. Push closer tube to door frame and connect to small bracket with long connecting pin

CAUTION: FOLLOWING STEP NO.14 THE CLOSER TUBE WILL SWING AWAY FROM THE DOOR WHENEVER THE LONG CONNECTING PIN IN THE SMALL BRACKET IS REMOVED. WHEN REMOVING LONG CONNECTING PIN FOR ADJUSTMENT, GRASP THE CLOSER TUBE FIRMLY AND KEEP AWAY FROM ITS PATH.

Customer Service

1-877-671-7011 www.allegion.com/us

CLOSER ADJUSTMENT

A. SPEED ADJUSTMENT

Rotate air adjustment screw at end of closer tube: Clockwise for slower, counter clockwise for faster.

B. LESS LATCHING FORCE

Disconnect closer tube from small bracket and repeat step 14. Position closer tube 45 degrees from door (rather than 90 degrees) and reconnect.

C. MORE LATCHING FORCE

Disconnect closer tube from small bracket. Hold spring hub in place, remove short connecting pin and pull closer rod out of spring hub. Disengage hook end of large spring and rotate spring hub to next slot (or two slots for extra heavy latching force.)

(NOTE: If required, a wrench (1-1/16") can be used to rotate spring hub to aid in assembly).

CAUTION: DO NOT ENGAGE SPRING MORE THAN TWO SLOTS BEYOND 90 DEGREES AS PERMANENT CLOSER DAMAGE MAY RESULT.

Reassemble closer rod to spring hub and insert short connecting pin. Reconnect closer to small bracket.

D. SNAP-ACTION LATCHING

To reduce the snap-action latching speed (the last few inches of travel) for smoother, more quiet operation, remove the long connecting pin from small bracket and relocate in REAR hole of closer tube.

Periodically lubricate bearing surfaces at top and bottom of large bracket and closer rod as necessary.

For future reference; fold these instructions, place them in back of large bracket, and slide cover over large bracket.

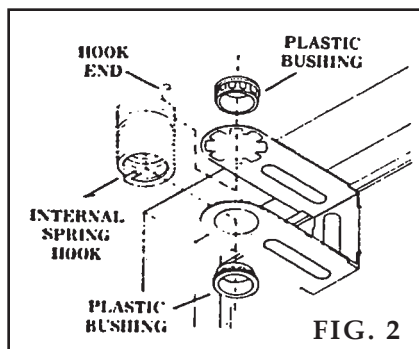
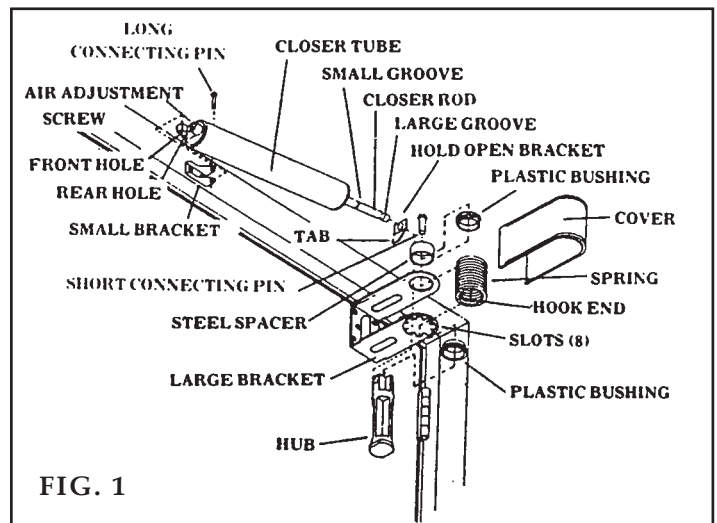

TEMPLATE "B" (FOR CLOSER MOUNTED ON DOOR)

