

ROLLER LATCH

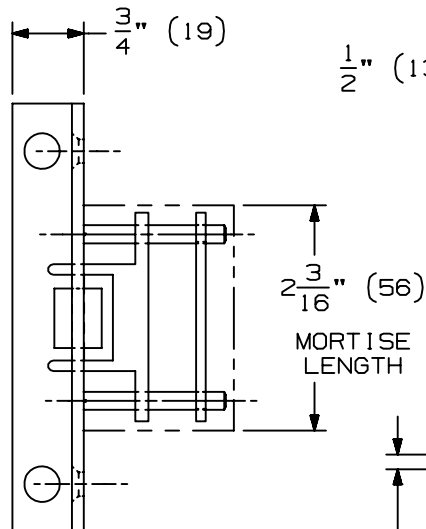

STRIKE

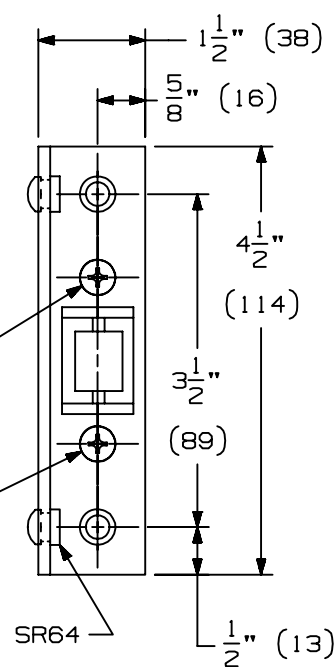
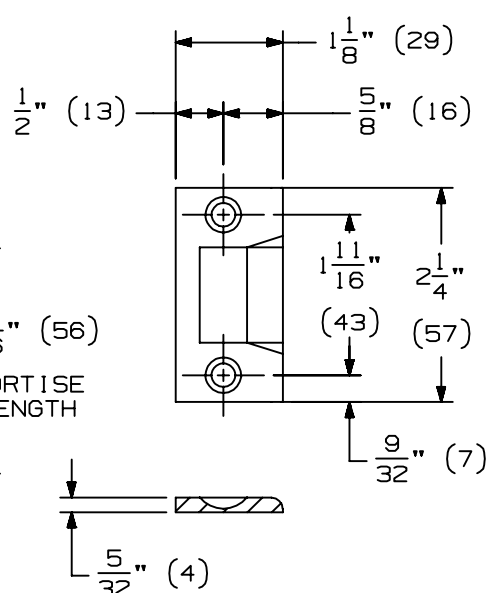

ADJUSTING SCREWS SEE THAT ROLLER EXTENDS EVENLY AND IS PARALLEL WITH DOOR.

HEAD FRAME MOUNTING

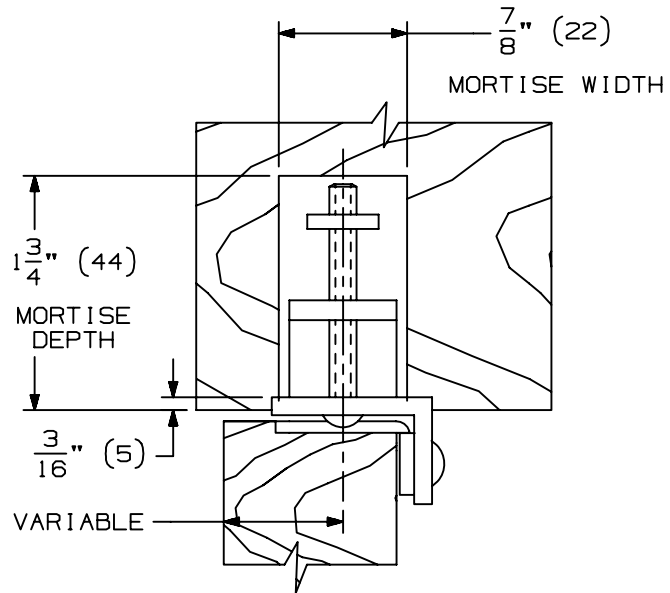

SIDE JAMB MOUNTING

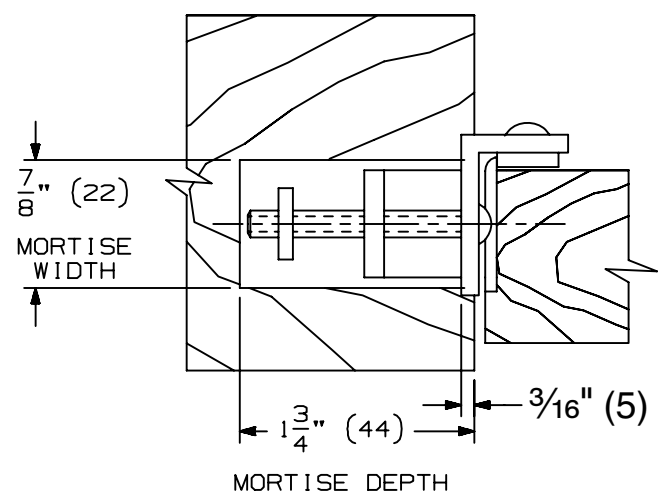

NOTES:  
1. HOLLOW METAL DOORS & FRAMES SHOULD BE PROPERLY REINFORCED WITH A 3/16" (5) MINIMUM THICKNESS PLATE.

	QTY	SCREW DETAILS
LATCH	2	10 X 1 1/2" FPHSMS
STRIKE	2	8 X 1" FPHSMS

**IVES** RL1152 ANGLE ROLLER LATCH INSTALLATION TEMPLATE



NOTE: DIMENSIONS IN ( ) ARE MILLIMETERS.

TEMPLATE NUMBER: INST.RL1152\_b

DATE: 6-6-13