

ROLLER LATCH

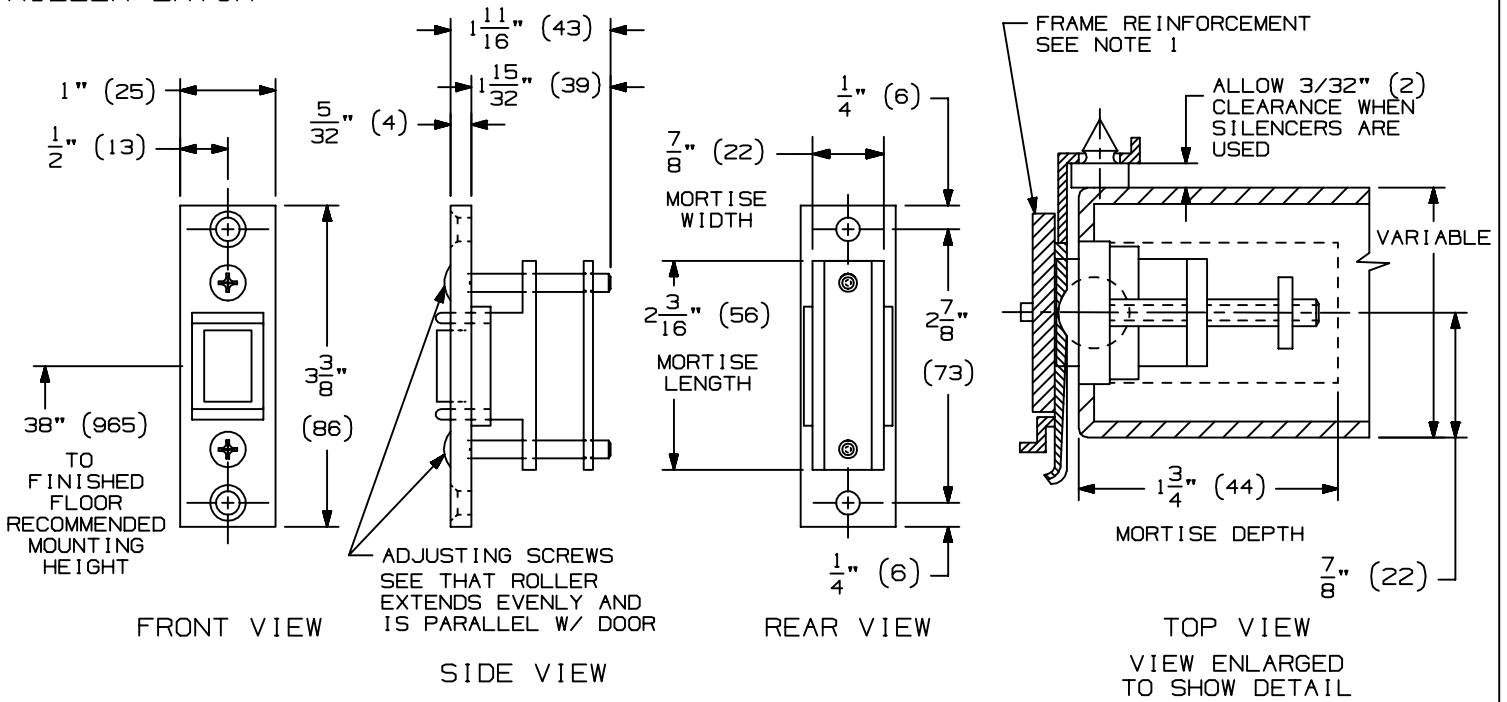

STRIKES

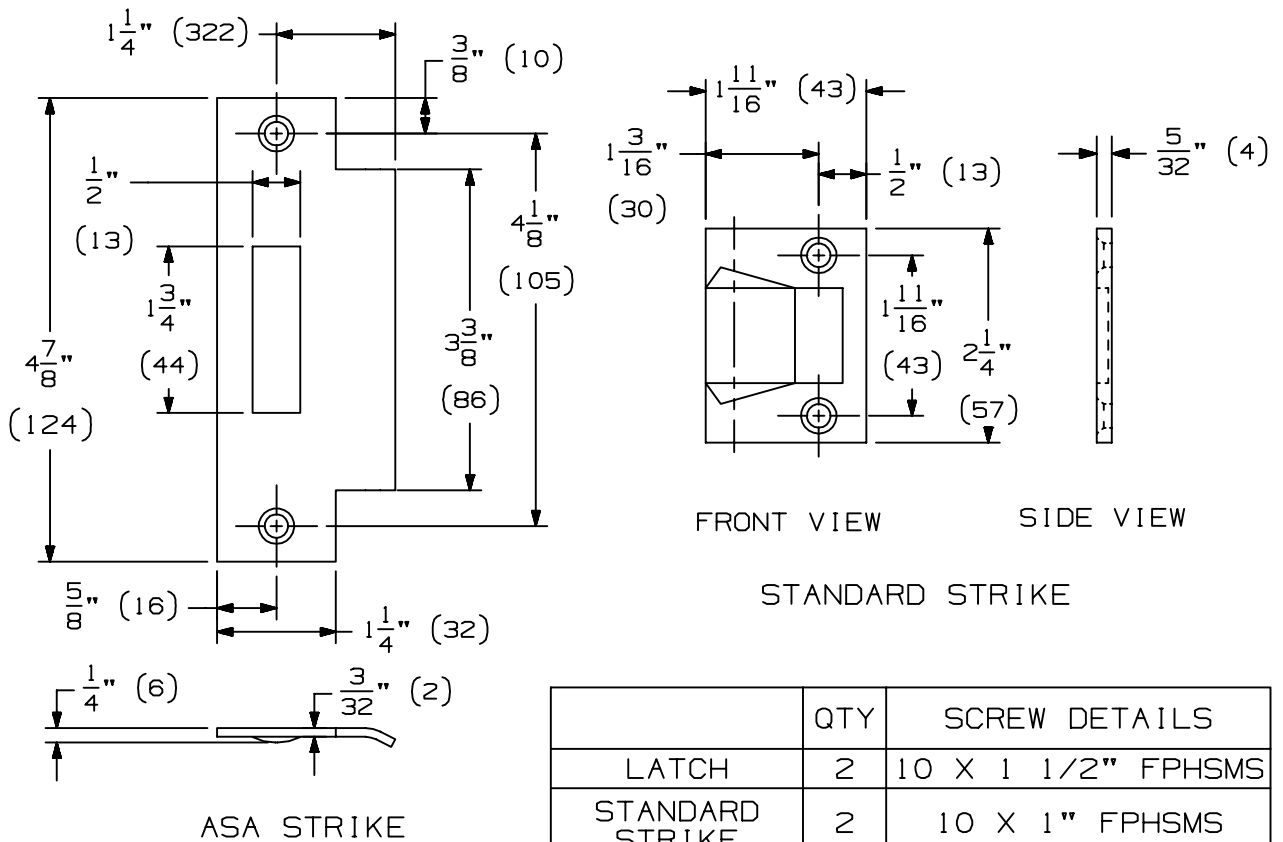

NOTES:

1. HOLLOW METAL DOORS & FRAMES SHOULD BE PROPERLY REINFORCED WITH A 3/16" (5) MINIMUM THICKNESS PLATE.

IVES

RL30 ROLLER LATCH
 INSTALLATION TEMPLATE

IR Ingersoll Rand
 Security Technologies

NOTE: DIMENSIONS IN () ARE MILLIMETERS.

TEMPLATE NUMBER: INST. RL30_A

DATE: 08-19-13