

RLBD

AD Series Dry Contact Relay Board

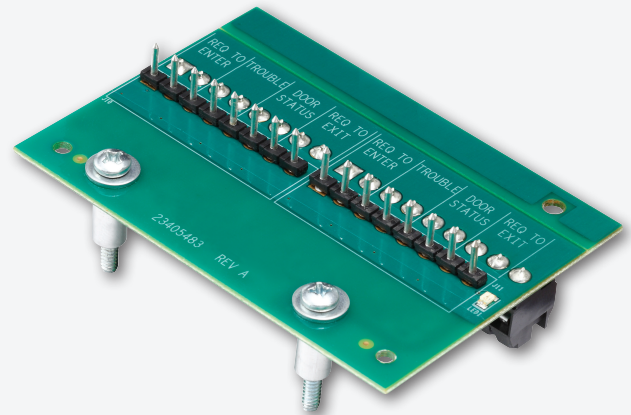

Overview

The Schlage AD Series Relay Board (RLBD) is an add on board used on the PIM400-TD2 and PIB300-2D for access control systems that require dry contact closures for supervised inputs.

The optional RLBD relay board removes the need for additional wired relays which can be cumbersome to source, complicated to install, and difficult to troubleshoot. The use of this board over custom wired solutions increases system reliability and reduces installation labor.

The RLBD is not required for integration of the PIM400-TD2 or the PIB300-2D where the access control system can accept unsupervised inputs.

Features & Benefits

- Use with PIM400-TD2 or PIB300-2D
- Red LED light indicates power status
- Longer cycle lifetime than traditional mechanical-based relay solutions
- Access point status signals
 - Request-to-enter
 - Request-to-exit
 - Door position/status
 - Tamper switch

RLBD Specifications

Voltage maximum (contact-to-contact)	28V
Maximum contact current	110 mA
“Open” state resistance	5 mega-ohms
“Closed” state resistance	2 ohms
Dimensions (H x W x D)	2.1" x 3.5" x 1.0" (5.33 cm x 8.89 cm x 2.54 cm)
Weight	0.125 lb (56.7 g)
Operating temperature	-31°F to 151°F (-35°C to 66°C)
Operating humidity	0-100% non-condensing

Available through one of our GSA schedule 84 approved distributors

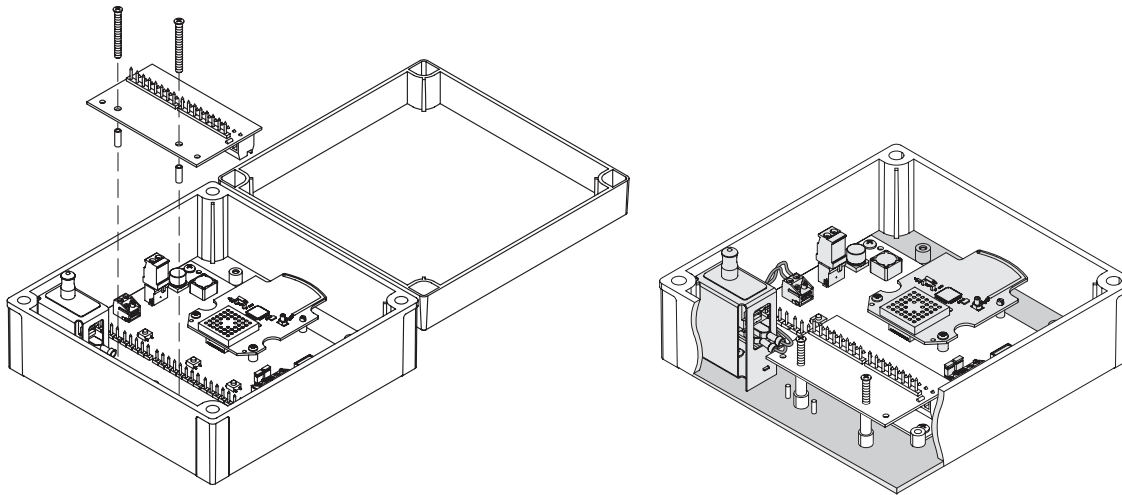

Installation of RLBD in a PIM400-TD2