



P518-421

AD-CY, AD-MS, AD-933



AD-Series Reader Replacement
Remplazo del lector de la serie AD
Remplacement du lecteur de séries AD

Installation Instructions
Instrucciones de instalación
Instructions d'installation

Note	Nota	Remarque
If installing reader on WPR400, see the user guide for reader installation instructions.		
Si está instalando el lector en el WPR400, consulte la Guía del usuario para las instrucciones de instalación del lector.		
Si vous installez le lecteur sur le WPR400, consultez le guide d'utilisation pour les instructions relatives à l'installation du lecteur.		

	ATTENTION: Electrostatic Sensitive Device
	ATENCIÓN: Dispositivo sensible electrostático
	ATTENTION : Dispositif sensible aux décharges électrostatiques

- | | | |
|---|--|--|
| <ol style="list-style-type: none"> 1. Remove power. 2. Find drawing of lock type (Cylindrical, Mortise, or Exit Device). 3. Remove existing reader as shown. 4. Install new reader. 5. Reassemble in reverse order. 6. Reconnect power. | <ol style="list-style-type: none"> 1. Desconecte la corriente. 2. Encuentre el dibujo del tipo de cerradura (cilíndrica, de muesca o de dispositivo de salida). 3. Quite el lector existente como se muestra. 4. Instale el lector nuevo. 5. Vuelva a ensamblar en orden inverso. 6. Vuelva a conectar la corriente. | <ol style="list-style-type: none"> 1. Coupez l'alimentation électrique. 2. Repérez le tracé du type de serrure (cylindrique, à mortaise ou dispositif de sortie de secours). 3. Retirez le lecteur actuel, tel qu'illustré. 4. Installez un nouveau lecteur. 5. Remontez en ordre inverse. 6. Rétablissez l'alimentation électrique. |
|---|--|--|

Cylindrical or Mortise Cilíndrico o de muesca Cylindrique ou mortaise

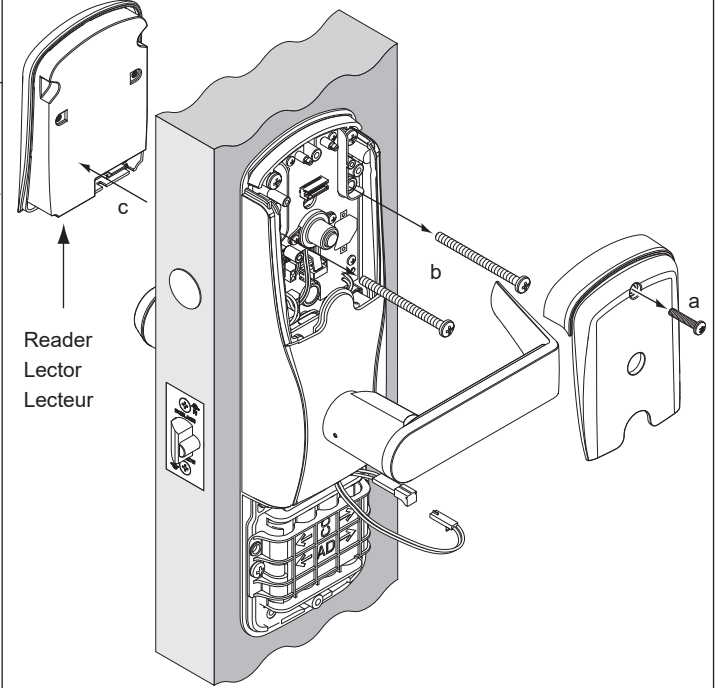

Exit Device Dispositivo de salida Dispositif de sortie de secours

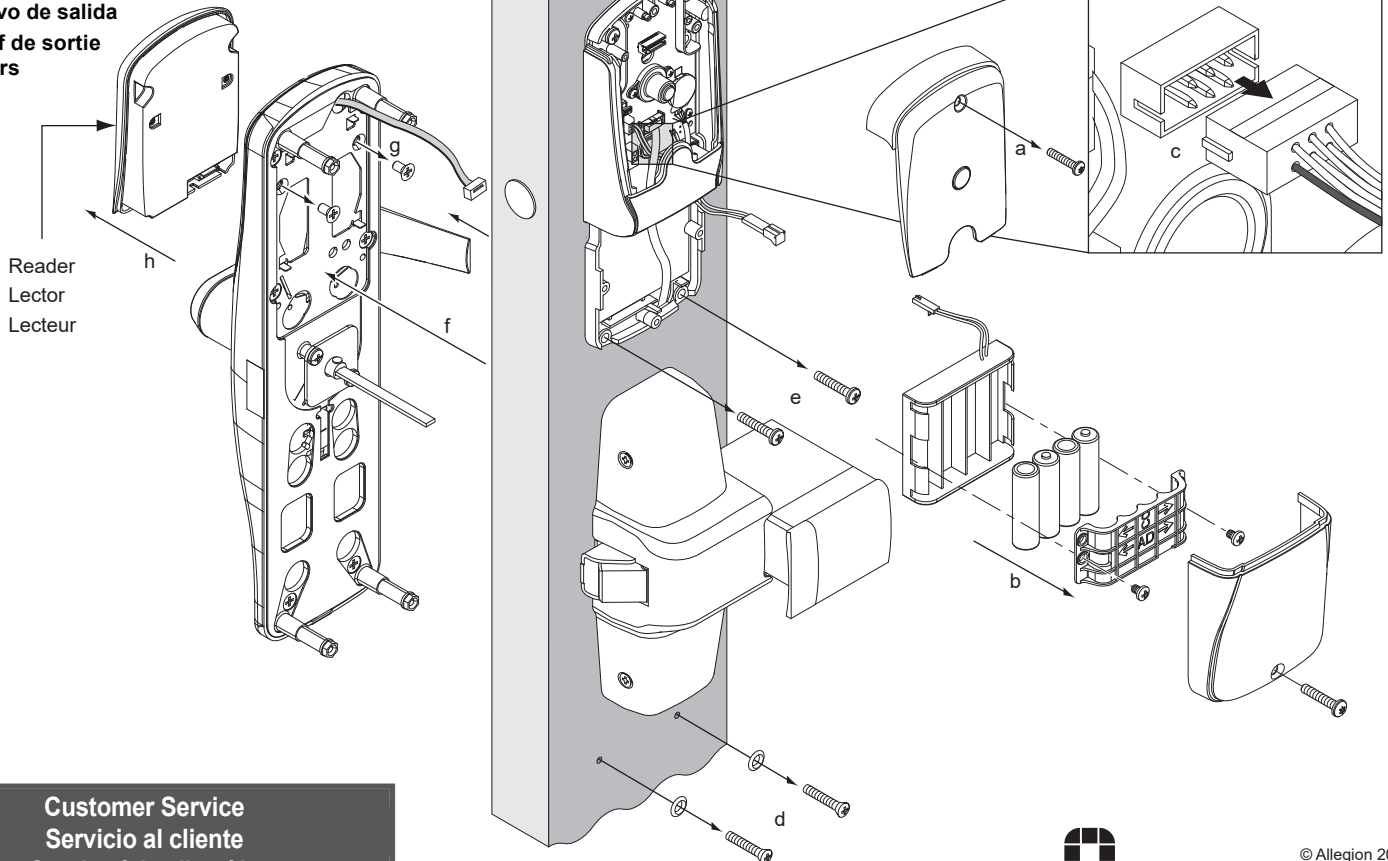

Customer Service
Servicio al cliente
Service à la clientèle

1-877-671-7011 www.allegion.com/us



© Allegion 2018
P518-421 Rev. 03/18-b