



575 Birch Street, Forestville, CT 06010
 Phone (866) 322-1237 Fax (866) 322-1233
 WWW.LOCKNETICS.COM

CL-CONTROLLER

UNIVERSAL ACCESS CONTROL SYSTEM

INSTALLATION AND WIRING INSTRUCTIONS

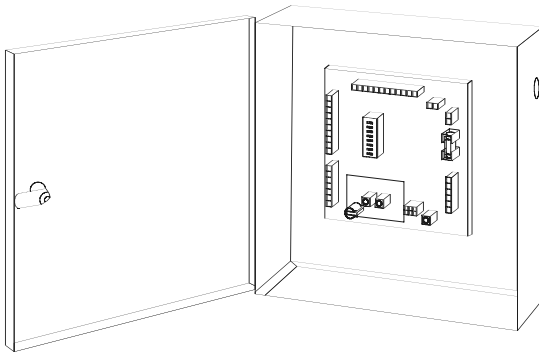

CL-CONTROLLER
UNLIMITED USERS ALLOWED

- 2000 AUDIT EVENTS
- SOFTWARE-MANAGED TIME ZONES
- SOFTWARE-MANAGED HOLIDAY EVENTS
- SMARTIME FUNCTIONALITY
- MAGNETIC STRIPE CARD OR MAGNETIC STRIPE CARD + PIN ACCESS

TABLE OF CONTENTS:

Specifications..... 2
 How to Get Started..... 2
 Typical System Installation..... 2
 Overview of Installation Steps..... 3
 Dip Switch Settings..... 3
 Wiring Connections..... 4
 Access Control Device Wiring..... 5
 Definition of Functions..... 5
 Default Codes..... 5
 Programming: General Information. 6
 Programming Master iButton/card... 6
 Erasing Memory..... 6
 Advanced Programming Features... 6
 Sample Wiring Diagrams..... 7
 Use of the PB-1 Button..... 8
 Trouble Shooting..... 8
 Use of the MOV spike suppressor... 8

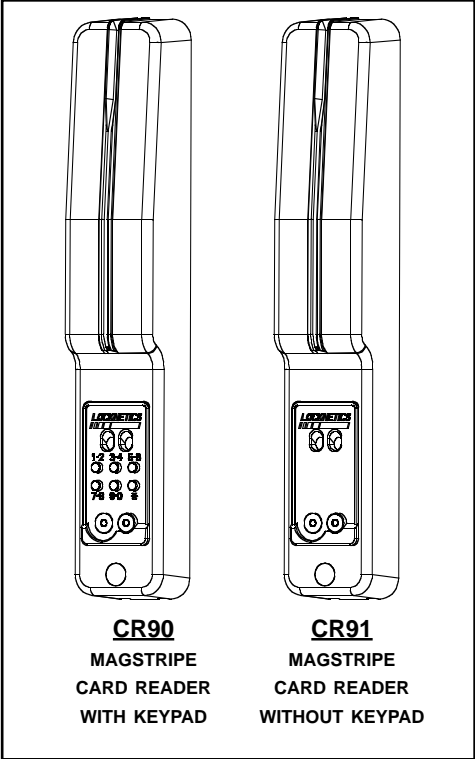

PLEASE READ ALL INSTRUCTIONS PRIOR TO INSTALLING THE SYSTEM.
 HANDLE THE EQUIPMENT CAREFULLY.

IMPORTANT! This manual is intended to be kept for programming, maintenance, and trouble shooting purposes. *Do not dispose of after installation.* Please present this manual to facility manager upon completion of installation.





SPECIFICATIONS:

Electrical:

Input Voltage: 12 to 28 VAC/VDC
 Current Draw: 200mA max.
 DC Output Voltage (with AC input): 1 amp max. (Matches input voltage)

Control Relays:

Main -DPDT contacts, 5 amp max @ 30VDC
 Aux -SPDT contacts, 5 amp max @ 30VDC
 Alarm -SPDT contacts, 5 amp max @ 30VDC

Unique Users Allowed:

UNLIMITED

CARD READER - ENVIRONMENTAL:

Model:	Temp (C/F) -----lower	Temp(C/F) -----upper	Environmental: Wet?	Distance to Controller (Max) Meters/Feet
CR90 / CR91	-20 / -4	60 / 140	interior or sheltered exterior	61/200

HOW TO GET STARTED:

The CL-CONTROLLER can be interfaced to the CR90, a magnetic stripe card reader with a keypad. The CL-CONTROLLER may have been ordered with the PS option (505-EIR power supply in the same enclosure). If it does not have a supply, one will be required. Make sure that the supply chosen will meet the electrical requirements of all components in the system. Note that electrical power dissipates over long wire runs, so it is important that the equipment be located close to the opening it is controlling.

Consult national electric code handbook for information regarding wire run lengths and minimum required wire gauge and type for the voltage and current in the system.

TYPICAL SYSTEM INSTALLATION: A typical installation consists of a locking device (magnetic lock, electric strike, etc.), a power supply, a CL-CONTROLLER, an access control device (CR90 Card Reader w/Keypad), an exit control (exit device, pushbutton, etc.), and door cord or electric hinge. Any installation involving modification or specification of an opening which is considered to be a *means of egress* (emergency exit) or a *fire rated opening* must conform to all local and national life safety and building codes. The specific gage and number of wires will vary with the kind of equipment used, the intended function, and local and national building codes. In most cases it is required that magnetic locks open in the event of a fire alarm condition. (Consult local authority having jurisdiction.)

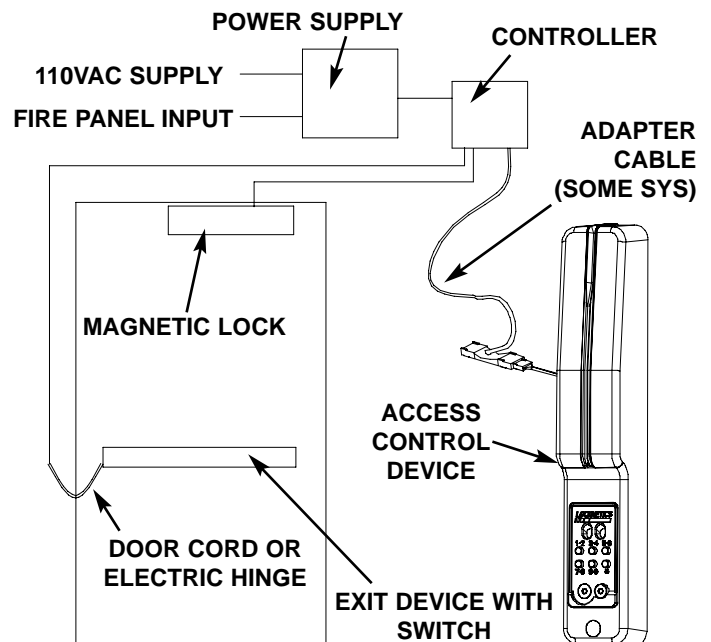

OVERVIEW OF INSTALLATION STEPS:

1. INSTALL COMPONENTS

- A. Determine where each component will be located. Mount Controller and Power Supply to Wall. Run conduit as required by local and national codes.
- B. Follow instructions included with Access Control device to mount it and run wires to controller.
- C. Mount Lock.

2. MAKE WIRING CONNECTIONS

- A. Set Dipswitches correctly for your system.
- B. Make wiring connections as required.
- C. Use of the MOV spike suppressor (see page 8).
- D. Connect Power

3. CONFIGURE AND PROGRAM SYSTEM

- A. Initialize Master iButton/Card as required.
- B. Configure and Program System.
- C. Test System.

1. SET THE EIGHT DIPSWITCHES ON SW1 FOR PROPER FUNCTION:

SW1

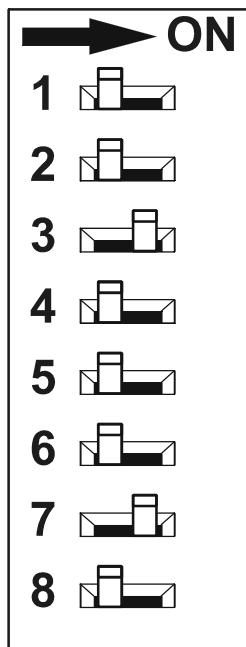

- Dipswitch 1 NOT USED
- Dipswitch 2 REX ALARM RESET: OFF= REX DOES NOT RESET ALARM
ON = REX DOES RESET ALARM
- Dipswitch 3 *ALARM RELAY: OFF=RELAY DE-ENERGIZED IN ALARM
ON = RELAY ENERGIZED IN ALARM
- Dipswitch 4 **ANTI-TAILGATE: OFF=DISABLE, ON=ENABLE
- Dipswitch 5 NOT USED
- Dipswitch 6 **DOOR FORCED/PROPPED: OFF=DISABLE, ON=ENABLE
- Dipswitch 7 AUTOMATIC RELOCK ON POWER-UP: OFF=RESET REQUIRED
ON=AUTOMATIC RELOCK
- Dipswitch 8 NOT USED

NOTES:

* Dipswitch 3 OFF: Alarm relay is energized under normal condition. Therefore, when power is lost, an alarm condition will occur. If Dipswitch 3 is set to ON, then the controller will energize the relay in an alarm condition. With this setting, loss of power will not be an alarm condition.
IMPORTANT! This setting will affect the "normal" condition of the relay terminals. (See wiring on next page.)

** These functions require a door status switch to be wired to the controller. The switch must be closed when the door is closed. (See wiring on next page.)

2. MAKE WIRING CONNECTIONS: Note that the main relay is a double pole, double throw relay. TB4 will put out DC unregulated voltage up to one Amp. Note that it is not necessary to use this terminal if your system already uses DC voltage from a power supply. NOTE: Terminal blocks are removable (except TB4).

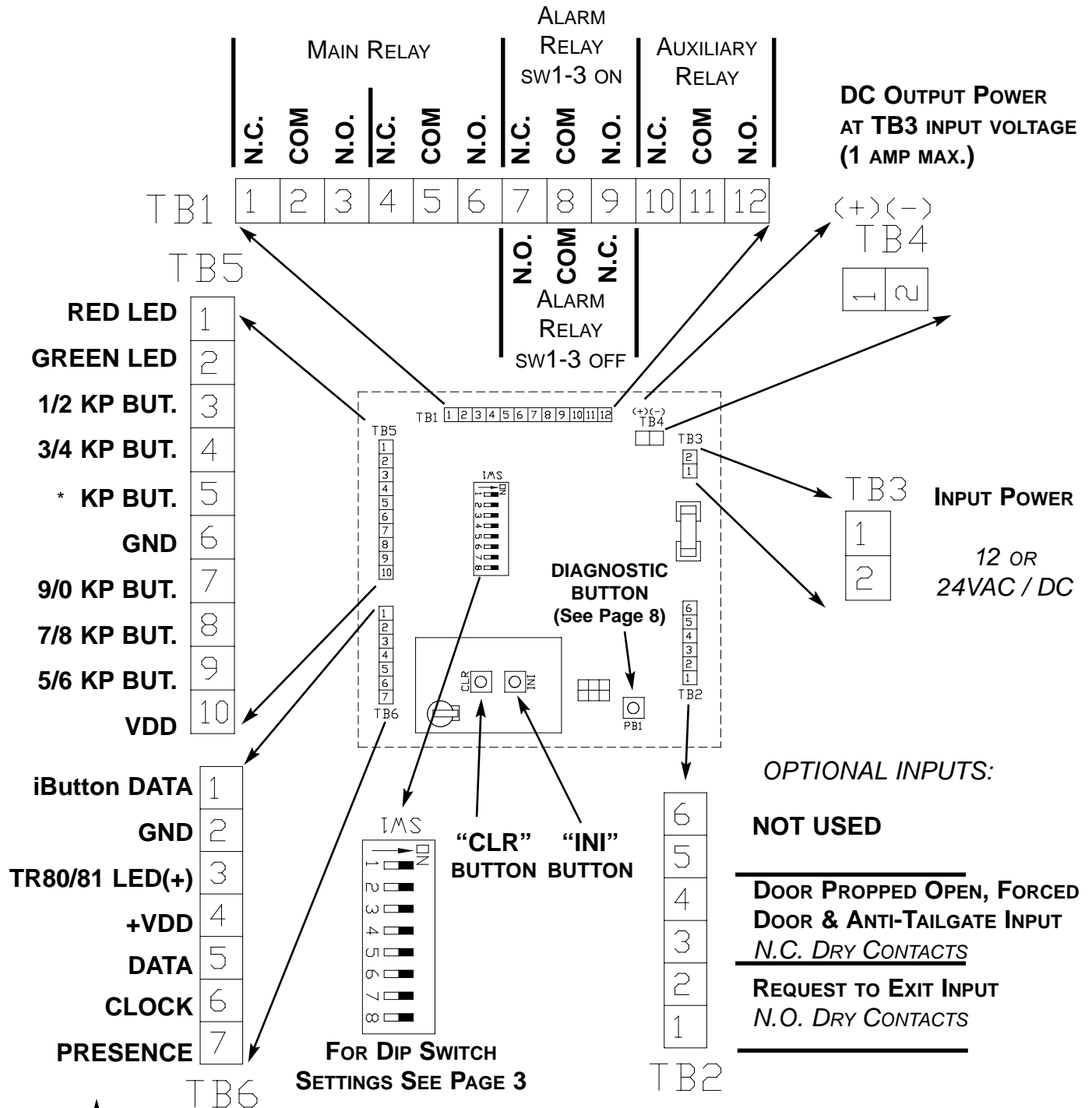

Request to Exit: Closing contacts will activate relays for six seconds. The timer is computer programmable only.

Door Prop: Triggers Alarm Relay when door is held open for 30sec. (Requires door position switch.)

Anti-Tailgate: Allows relocking of door immediately upon closing. (Requires door position switch.)

Forced Door: Triggers Alarm Relay when door is forced open without a legal release. (Requires door position switch.)



Make connections to the access control device or adapter cable as required. *Be sure that all wiring is correct before power is applied. If more than one card reader or prox card reader must be wired, a CR2 adapter board will be required. Refer to the instructions included with the adapter board for special wiring instructions.*

CARD READER	TB5										TB6						
	<GREEN>	<BLUE>	WHITE	WHITE/BLACK	WHITE/BROWN		WHITE/RED-	WHITE/ORANGE	WHITE/YELLOW	<GREY>	<BROWN>	<BLACK>(GND)		<VIOLET> (+5v) >	<RED>	<ORANGE>	<YELLOW>
	1	2	3	4	5	6	7	8	9	10	1	2	3	4	5	6	7

NOTES:

1. All 15 wires shown must be connected on the CR90 models.
2. On CR91 models, connect the 9 wires which are <bracketed> to the terminals.

DEFINITION OF ACCESS FUNCTIONS AND FACTORY DEFAULTS:

	Factory Default	
FACTORY CONSTRUCTION CARD	13579	This card is shipped with the equipment and is only to be used for testing the equipment immediately following installation. Once the Master Code is entered (see below), the Factory Construction Card becomes ineffective.
MASTER	97531*	Allows access to programming functions. Will not activate relays. Factory Construction and User Cards will not function after entering the Master Code (or Master iButton/Card) until computer programming is complete or 30 seconds have expired.
NORMAL ACCESS _____		No factory default. Activates main relay for relock time delay. Will reset alarm condition.
TOGGLE _____		No factory default. Activates main relay until same or another Toggle credential* is entered.
LOCKOUT _____		No factory default. "Freezes" the lock in its present condition, either locked or unlocked, until the same or another Lockout credential is entered.
SUPERVISED ACCESS _____		No factory default. This type of credential allows access only when used with another Supervised Access credential. The second credential must be entered within five seconds of the first one. The order that they are entered does not matter. Both the first and second supervised access credentials entered will be reported on the audit trail report.
PASS-THRU _____		No factory default. This type of access credential allows access even if the lock is in the "Freeze/Lockout" mode. After the relock time delay, the controller will resume its "Lockout" status.

**NOTE: A credential could be a card only or card + PIN*

PROGRAMMING: GENERAL INFORMATION

Programming the CL-CONTROLLER is done by computer programming only. Time zone controls for the CL-CONTROLLER is also done by computer programming. See the help files and software documentation for details.

The units come from the factory with a "Factory Construction Card" and a PIN. This card is shipped with the equipment and is only to be used for testing the equipment immediately following installation. Factory Construction Cards and User Cards will not function after entering the Master Code (or Master iButton/Card) until computer programming is complete or 30 seconds have expired.

Whenever the lock is reset (memory erased) it will return to factory default.

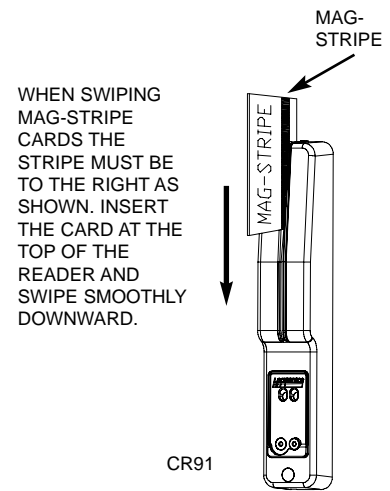

Creating a Master iButton/Card (For Computer Programming):

- A. Open the cover of the controller.
- B. Press the "INI" button three times.
The red LED will come on and stay on.
- C. Touch Master iButton to reader (or swipe the Master card) .
The LED(s) will flash to indicate acceptance.
- D. When you are finished, press the "INI" button once.
The red LED will turn off.

NOTES:

- 1. Refer to instructions included with the programmer/software that you will use to program for more information regarding programming.
- 2. The Master iButton or card is used for initiating programming. It will not unlock the door.

ERASING MEMORY (RETURN TO FACTORY DEFAULT SETTINGS):

Important: Resetting will delete all void entries, audits, Master iButton/Card, time zones, holidays and smarttime events. All time delays and default codes will be restored to default values.

- 1. Open cover of controller and set dipswitches according to chart on page 3.
- 2. Depress "CLR" microswitch three times. The red LED will turn on.
- 3. The operation is complete when the red LED turns off. (approx. 10 sec)

ADVANCED PROGRAMMING FEATURES:

There are several advanced features which the CL-CONTROLLER supports when factory configured:

DOORBELL FUNCTION: The doorbell function will change the state of the AUX relay for one second anytime the * key is pressed. This can be used to sound a buzzer to alert someone inside that someone is at the door. (Best if used with a sign which informs the guest that the * button is a doorbell.)

REX INPUT CONFIGURATION: The request to exit input is configured to activate the MAIN relay only. Note that the REX input can also be configured to clear or not to clear an alarm condition (see dipswitch settings on p.3)

SAMPLE WIRING DIAGRAMS:

Below are two sample wiring diagrams showing only the power supply connections, connections to fail safe or fail secure lock, request to exit (REX) and door status switch. Note that the door status switches completely optional, depending on the design of your system. See dip switch settings on page 3.

IMPORTANT: SEE PAGE 8 FOR USE OF THE MOV SPIKE SUPPRESSOR (INCLUDED).

CL-CONTROLLER W/ PS OPTION (505-EIR POWER SUPPLY):

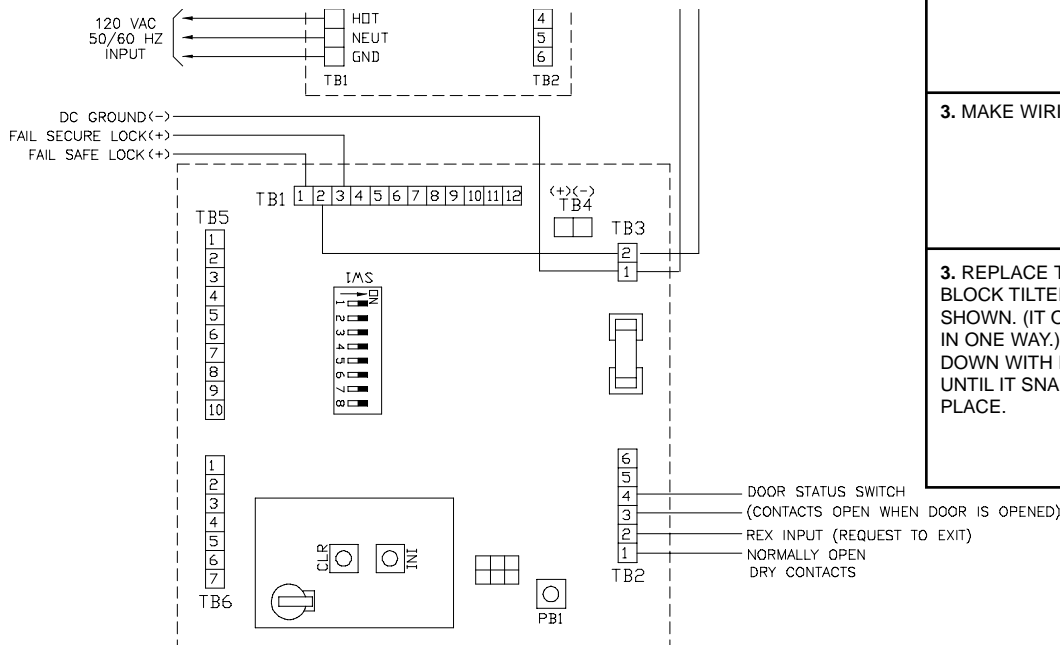

REMOVABLE TERMINALS:

IMPORTANT! REMOVE SYSTEM POWER BEFORE REMOVING TERMINAL BLOCKS. ALL TERMINAL BLOCKS ARE REMOVABLE EXCEPT TB4.

1. INSERT FLAT SCREW-DRIVER INTO NOTCH IN TOP OF TERMINAL BLOCK.

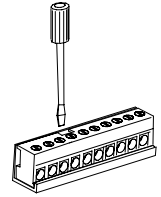

2. PRY TERMINAL BLOCK AWAY FROM HOLDER.

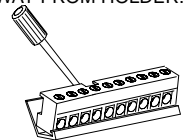

3. MAKE WIRING CONNECTIONS.

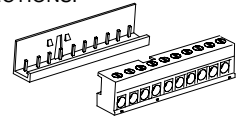

3. REPLACE TERMINAL BLOCK TILTED AS SHOWN. (IT ONLY GOES IN ONE WAY.) PRESS DOWN WITH FINGER UNTIL IT SNAPS INTO PLACE.

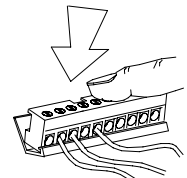

CL-CONTROLLER W/ AC TRANSFORMER:

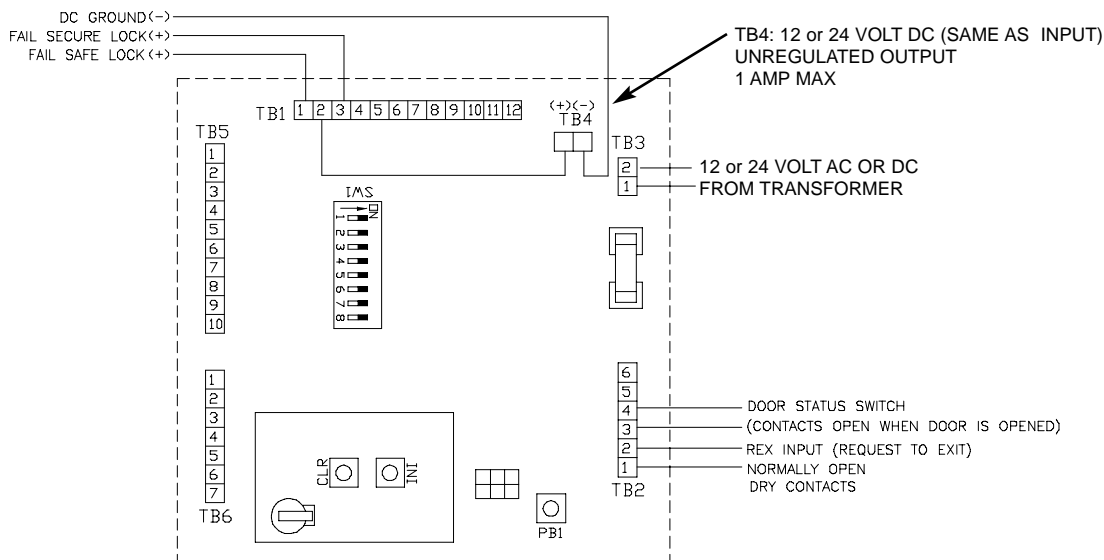

USE OF THE DIAGNOSTIC BUTTON PB-1:

The pushbutton PB-1 (see page 4 for location) is for diagnosing wiring problems which can occur during installation. When pushed, it will change the state of all three relays for as long as it is pushed (Exception: if the alarm relay is already set to be energized on powerup - see page 3 for setting - it will not change state.) In addition, LED(s) on a keypad, reader, etc. will light while the button is being depressed. When the button is released, the relays will remain energized for the remainder of the relock time delay if the button is held past the relock delay, the relays will de-energize as soon as it is released. This button is intended for checking out wiring logic etc. before the system is programmed.

TROUBLE SHOOTING:

Some common problems associated with the installation of the CL-CONTROLLER can be easily recognized and corrected:

Problem:

Possible Solution:

System has power but lock won't lock.
No lights on.

Check wiring. Possibly the relay is wired wrong or power is not applied to lock.

System has power but lock won't lock.
LEDs on keypad/reader flashing.

Check wiring. Possibly the rex input is closed (instead of open).
Dipswitch SW1-7 is off. Switch to ON. Remove power. Reapply power.

Lights on keypad work but programming steps don't seem to function.

Initialized Keypad
Wrong master code, iButton, or Card.

Door Forced/Propped Alarm configured but not Active

Door Position switch not installed or wired properly.
SW1-6 not set to ON.

USE OF THE MOV SPIKE SUPPRESSOR:

Some manufacturers of electric locks do not include built in spike suppressors. When the lock is turned off a high voltage spike can cause sensitive controller electronics to malfunction. If there is any doubt about the presence of spike suppression devices in a product the use of the MOV provided is required. It should be wired into the system as shown:

