

Table of contents (click below or use bookmarks)

- General information 5**
 - Introduction.....5
 - Standards5
 - Dimensioning.....5
 - Terminology.....5
 - Literature.....5
 - Errors and omissions5
- Technical publications.....6**
 - SDI.....6
 - HMMA 8
 - ANSI.....10
- Handing procedures 11**
- Frame and door nomenclature12**
- Typical hardware locations 14**
 - Doors and frames with 3 Hinges (1½ Pair) 14
 - Doors and frames with 4 Hinges (2 Pair) 15
 - Doors and frames with 5 Hinges (2½ Pair)16
 - Dutch doors17
- Comparative hinge and strike locations 18**

This page intentionally left blank

Introduction

Introduction

After more than seven decades of quality, craftsmanship and service leadership, Steelcraft continues to be recognized as the world's leading manufacturer of steel doors and frames.

Steelcraft manufactures the most complete line of steel doors and frames. These products are produced from the highest quality of commercial carbon steel or galvanized steel as specified.

Steelcraft frames are designed for virtually all types of wall construction. The flush frame is primarily intended for installation as part of the wall framing system(s), while the Drywall Frames are specifically designed for drywall construction.

Steelcraft also offers the broadest line of labeled (Fire Rated) doors and frames for either Positive or Neutral fire test environments. Steelcraft continues to be very active in assisting building code officials in the adoption of more stringent and realistic codes for Fire Doors and Frames.

The Steelcraft Architectural Stick System consists of standard frame components that are pre-engineered for assembly and fabrication by the local Steelcraft distributor. This allows for unlimited opportunities to meet the architectural and aesthetic needs of extensive window wall, store front and entrance units.

Steelcraft is devoted to the manufacture, service and continuous improvement of steel doors, frames and their components. A measure of this commitment can be found in the great number of door and frame innovations that are now common in the industry—pioneered, designed, developed, and in certain products, patented by Steelcraft.

This Technical Manual is designed to provide Architects, Engineers, Specification Writers, End Users and Distributors with the necessary information to specify the correct Steelcraft product to meet the application and functional needs of the project. In addition to providing the industry with the highest quality of steel doors, frames and components, Steelcraft offers the widest selection of sizes, styles and designs to compliment virtually any architectural, aesthetic, security or safety requirement.

Standards

Steelcraft is a long-standing and very involved member of several training and industry organizations, which are also dedicated to the continual improvement of the Commercial Door and Frame Markets. Some of the major trade associations of which Steelcraft is an active member include:

SDI Steel Door Institute

HMMA Hollow Metal Manufacturers' Association

DHI The Door and Hardware Institute

Dimensioning

All dimensions shown in this manual are based on the imperial (feet and inches) dimensions system, with the equivalent metric (millimeters) shown in parentheses. Steelcraft has and does supply projects globally in both Imperial and Metric dimensioning. It is the responsibility of the architect, specifier and purchaser of the doors and frames to clearly indicate the dimensional system required to be met. With the multitude of building components interfacing with the door and frame installations, this is extremely critical and requires a clearly stated and understood dimensioning policy.

Steelcraft Metric Policy

Jobs ordered in metric dimensions will be supplied to the actual dimensions indicated on orders placed to Steelcraft. No

dimensions will be considered nominal, unless they are clearly indicated and supported by a clearly stated metric dimensional standard. All critical, installation and functional tolerances will be in accordance with the industry tolerance published in and by the Steel Door Institute (SDI) and the Hollow Metal Manufacturers Association (HMMA).

Terminology

The terms covered in this manual are in accordance with those published by:

SDI ANSI A250.7 Nomenclature for:
Standard Steel Doors and Steel Frames

HMMA HMMA 801-05 Glossary of
Terms for Hollow Metal Doors and Frames

Literature

Literature or standards referenced in this manual can be obtained directly from the publisher of that literature. To obtain any standard referenced in this manual, refer to the organizations listed. Downloadable documents may be obtained by connecting to the organization's website.

ANSI American National Standards Institute
<http://www.ansi.org>

ASTM American Society for Testing and Materials
<http://www.astm.org>

CSI Construction Specifications Institute
<http://csinet.org>

DHI Door and Hardware Institute
<http://www.dhi.org>

HMMA Hollow Metal Manufacturers' Association
Division of NAAMM
<http://www.naamm.org>

NAAMM National Association of Architectural
Metal Manufacturers
<http://www.naamm.org>

NFPA National Fire Protection Association
<http://www.nfpa.org>

SDI Steel Door Institute
<http://www.steeldoor.org>

UL Underwriters Laboratories, Inc.
<http://www.ul.com>

WH Warnock Hersey (Intertek ETL SEMKO)
<http://www.intertek.com>

Errors and omissions

Every effort has been made to ensure the accuracy and completeness of this Steelcraft Technical Manual. This manual is for use by qualified persons only. The information herein is subject to some interpretation, and from time to time, the data sheets will be updated whenever it is deemed necessary as new tests are conducted, new products and technologies are introduced and as specifications are revised. For these reasons, and because of the nature and scope of the subject, Steelcraft and its employees can assume no responsibility or liability for the absolute accuracy of the material contained herein or its use. The information in this Technical Manual is subject to change without notice and does not represent a commitment on the part of Steelcraft.

Please contact the Steelcraft Technical Service Department if you identify an error or omissions.

SDI 106-99*Recommended Standard Door Type Nomenclature*

This document contains Standard door type nomenclature ranging from flush (Type F) to Dutch doors (Type D). The use of the Standard nomenclature contained in the document will greatly simplify architectural drawing takeoff process and will do much to avoid confusion and errors which result from misinterpretation of these details.

SDI 108-04*Recommended Selection and Usage Guide for Standard Steel Doors*

This document was developed to establish guide criteria for the selection and usage of standard steel doors in such building types as apartment, dormitory, hotel/motel, hospital/nursing home, industrial, office and school.

SDI 109-04*Hardware for Standard Steel Doors and Frames*

This document contains a listing of hardware from various hardware manufacturers that is compatible for use on standard steel doors and frames. It covers various types of locks, exit devices, closers, holders, hinges, roller latches, flush bolts, and electric strikes.

SDI 110-84 (R2000)*Standard Steel Doors and Frames for Modular Masonry Construction*

This document contains information in respect to, as the title indicates, the installation of standard steel doors and frames in modular masonry construction. The basic module covered in the document as developed by the industry is 4".

SDI 111-00*Recommended Selection and Usage Guide for Standard Steel Doors, Frames and Accessories (A through H):***SDI 111-A***Recommended Standard Steel Door Frame Details*

Covers recommended steel door frame details as they are affected by common wall conditions.

SDI 111-B*Recommended Standard Details for Dutch Doors*
Standard dimensions for dutch doors.**SDI 111-C***Recommended Louver Details for Standard Steel Doors*

This document discusses, explains and details a variety of louver designs and size available for standard steel doors.

SDI 111-D*Recommended Door, Frame and Hardware Schedule for Standard Steel Doors and Frames*

Contains a suggested door, frame and hardware schedule form and defines "handing".

SDI Technical publications

Listed here, and on the following page, are the current Technical publications available from the Steel Door Institute.

All documents in this list are part of the **SDI Fact File**.

Free downloads of these documents are available from SDI's Website:

<http://www.steeldoor.org>

SDI 111-E*Recommended Guidelines for The Use of Gasketing and Thresholds for Standard Steel Doors and Frames*

Contains details which represent the recommendations of the SDI in respect to weather-stripping of standard steel doors and frames.

SDI 111-F*Recommended Existing Wall Anchors for Standard Steel Doors and Frames*

A guide for architects to aid them in recognizing available options to the traditional sub buck detail which has been widely used in the past. It illustrates anchoring systems which are available in regular and labeled frames.

SDI 111-G*Recommended Standard Preparation for Double Type (Interconnected) Locks On Standard Steel Doors and Frames*
Dimensions for standard door and frame preparation for double type (interconnected) locks.**SDI 111-H***High Frequency Hinge Preparations for Frames*

Specifications for steel frames used in extremely high frequency or high use areas which need to be supplied with additional reinforcing to eliminate potential door sag.

SDI 112-97*Zinc-Coated (Galvanized/Galvannealed) Standard Steel Doors and Frames*

This document provides information regarding the galvanized sheet used in standard steel door and frame construction when a requirement for galvanized doors and frames is specified.

SDI 113-01*Standard Practice for Determining the Steady State Thermal Transmittance of Steel Door and Frame Assemblies*

This document establishes a minimum standard and a method of test for thermal effectiveness of steel door and frame assemblies under circumstances that might reasonably be considered normal field applications and conditions.

SDI

SDI 117-00

Manufacturing Tolerances Standard Steel Doors and Frames

This document is intended to furnish users and prospective users of standard steel doors and frames with practical information regarding mortise and manufacturing tolerances for both doors and frames.

SDI 118-02

Basic Fire Door Requirements

This document contains rules and other information in a condense simplified manner in respect to code requirements for the design and use of fire doors.

SDI 122-99

Installation and Troubleshooting Guide for Standard Steel Doors and Frames

This document covers field installation problems most commonly experienced with standard steel door and frame installations. Most problems encountered are because of inappropriate application of the products and/or improper installation.

**SDI 124-98**

Maintenance of Standard Steel Doors and Frames

This document is intended to serve as a general outline of maintenance activities needed for hollow metal doors and frames.

SDI 127 Series: *Industry Alerts (A through J):*

SDI 127A-99

End Closure Location

Industry Alerts - End Closure

SDI 127B-99

Door Edge Cutouts

Industry Alerts - Door Edge Cutouts

SDI 127C-99

Frame Cutout Limits

Industry Alerts - Frame Cutout Limits

SDI 127D-99

Electric Strikes In Stud Walls

Industry Alerts - Electric Strikes in Stud Walls

SDI 127E-01

Prime Painted Materials Alert

Industry Alerts - Prime Painted Materials Alert

SDI 127F-02

Butted Frames Rough Opening Sizes

Industry Alerts - Butted Frames Rough Opening Sizes

SDI 127G-02

Environmental Considerations Relating to Factory Painted Steel Doors and Frames

Industry Alerts - Environmental Considerations Relating to Factory Painted Steel Doors and Frames

SDI 127H-02

Water Penetration

Industry Alerts - Water Penetration

SDI 127I-04

Grouting Frames in Drywall

Industry Alerts - Grouting Frames in Drywall

SDI 127J-04

Bituminous Back-Coating of Frames

Industry Alerts - Bituminous Back-Coating of Frames

SDI 128-97

Guidelines for Acoustical Performance of Standard Steel Doors and Frames

This document shall provide guidelines for the specifying, designing, installing, and adjusting of standard steel doors and frames in Sound Control applications.

SDI 129-04

Hinge and Strike Spacing

A reference of standard locations used in the manufacture of steel door and frames by SDI member companies for a variety of door sizes.

SDI 130-05

Electronic Hinge Preparations

Practical information regarding an acceptable method for preparing frames for 4 1/2" electric hinges. This document will allow frame manufacturers to provide frames prior to having knowledge of the specific electric hinge being used.

SDI 131-04

Accelerated Physical Endurance Test Procedure for Steel Doors, Frames and Frame Anchors

This test procedure provides manufacturers with a method of quickly testing the performance of doors.

Drywall Slip-On Frames

This document illustrates step by step how to install Drywall Frames in less than 10 minutes. It also lists the many advantages of drywall slip-on frames.

HMMA Technical publications

Listed here, and on the following page are the current Technical publications available from the Hollow Metal Manufacturers Association, a Division of the National Association of Architectural Metal Manufacturers.

Free downloads of these documents are available from the HMMA/NAAMM Website:

<http://naamm.org/hmma/>

HMMA 800-96

Introduction to Custom Hollow Metal

It is the purpose of this manual to provide authoritative and unbiased technical information regarding the manufacture, design and use of custom hollow metal doors and frames.

ANSI/NAAMM HMMA 801-05

Glossary of Terms for Hollow Metal Doors and Frames

Defines commonly used terms in connection with Hollow Metal Work as they specifically apply to hollow metal doors and frames. These terms may be defined differently by other industries.

HMMA 802-07

Manufacturing of Hollow Metal Doors and Frames

This publication details the types of steel materials used and fabrication processes, including shearing, blanking, brake forming, limitations of break forming, welding and painting.

HMMA 803-97

Steel Tables

Values of minimum steel thicknesses taken from the Underwriters Laboratories, Inc. publication for gauge number and equivalent thickness are shown. ASTM and ANSI do not list gauge numbers in their standards which was the standard of referral prior to 1970.

HMMA 810-87

Hollow Metal Doors

This document reviews basic sizes, types, designs and construction of hollow metal doors.

HMMA 820-87

Hollow Metal Frames

This document details various elevation types, profiles, assembly and anchoring of Knock-Down (KD) and welded 3-sided and multiple opening hollow metal frames.

HMMA 830-02

Hardware Selection for Hollow Metal Doors and Frames

This publication is intended to acquaint the reader with commonly used door hardware that provides both aesthetic appeal and durable function.

HMMA 831-97

Hardware Locations for Hollow Metal Doors and Frames

Recommended locations for hardware on Custom Hollow Metal doors differ from those established for Standard Hollow Metal doors principally with respect to hinges, knobs and strikes.

HMMA 840-99

Guide Specifications for Installation and Storage of Hollow Metal Doors and Frames

A comprehensive review of the delivery, receiving, on-site storage and installation of Knock-Down (KD) and welded hollow metal frames and hanging of hollow metal doors.

HMMA 850-00

Fire Rated Hollow Metal Doors and Frames

Data on current practices within the industry are presented with emphasis on the requirements of the National Fire Protection Association (NFPA) and Model Codes. Fire testing, listing, labeling and certification services are thoroughly covered.

**HMMA 860-92**

Guide Specifications for Hollow Metal Doors and Frames

A CSI format specification intended as a guideline for the development of, and editing of job specifications for the application of specific job requirements related to Apartment Buildings, Dormitories, Military Barracks, and Motels.

HMMA 861-06

Guide Specifications for Commercial Hollow Metal Doors and Frames

A CSI format specification intended as a guideline for the development of, and editing of job specifications for the application of specific job requirements related to Schools, Hospitals, Industrial Buildings, Office Buildings, Hotels, Nursing Homes, Airports, and Convention Centers.

ANSI/NAAMM HMMA 862-03

Guide Specifications for Commercial Security Hollow Metal Doors and Frames

A CSI format specification intended as a guideline for the development of, and editing of job specifications for the application of specific job requirements related to Exterior Doors to Schools, Warehouses, Industrial Buildings, or Strip Stores.

ANSI/NAAMM HMMA 863-04

Guide Specifications for Detention Security Hollow Metal Doors and Frames

A CSI format specification intended as a guideline for the development of, and editing of job specifications for the application of specific job requirements related to Jails, Prisons, Detention Centers, and Secured Areas in Hospitals or Courthouses.

ANSI/NAAMM HMMA 865-03

Guide Specifications for Swinging Sound Control Hollow Metal Doors and Frames

A CSI format specification intended as a guideline for the development of, and editing of job specifications for the application of specific job requirements related to Television, Radio, Recording and Sound Studios, Theaters, and Music Rooms.

ANSI/NAAMM HMMA 866-01

Guide Specifications for Stainless Steel Hollow Metal Doors and Frames

A CSI format specification intended as a guideline for the development of, and editing of job specifications for the application of specific job requirements related to the use of Type 304 or 316 Stainless Steel for highly corrosive, moderately corrosive or aesthetic applications.

ANSI/NAAMM HMMA 867-06

Guide Specifications for Commercial Laminated Core Hollow Metal Doors and Frames

This specification presents the 2004 CSI Format (for the new CSI location for hollow metal doors and frame products) Master Format 2004 Section 08 11 13 and is intended as a guideline for the development of, and editing of job specifications for the application of specific job requirements related to commercial, laminated core, steel doors, and appropriate frame products

A250.3-2007

Test Procedure and Acceptance Criteria for – Factory Applied Finish Coatings for Steel Doors and Frames
Prescribes the procedure to be followed in the selection of material, chemical preparation, painting, testing, and evaluation of factory applied finish painted steel surfaces for steel doors and frames.

A250.4-2001

Test Procedures and Accepted Criteria for – Physical Endurance for Steel Doors, Frames, Frame Anchors and Hardware Reinforcing
A standard method of testing the performance of a steel door mounted in a pressed steel or channel iron frame under condition that might be considered an accelerated field operating conditions.

A250.6-2003

Recommended Practice for Hardware Reinforcing on Standard Steel Doors and Frames
Provides users of standard steel doors and frames with practical information regarding accepted design methods for reinforcing, and recommended practices for proper field preparation and installation of builders hardware.

A250.7-1997 (R-2002)

Nomenclature for – Standard Steel Doors and Steel Frames
Detailed definitions of terms common to the Standard Steel Door and Steel Door Frame Industry.

**A250.8-2003 (SDI-100)**

Recommended Specifications for Standard Steel Doors and Frames
This specification for swinging steel doors and frames offers a number of choices in both regular and fire rated door and frame constructions. The user must select from the specification the specific grades of doors and frames that best apply to the project. This specification covers sizes, types, materials, general construction requirements and finishing of 1³/₄" extra heavy duty steel doors, 1³/₄" heavy duty steel doors, 1³/₄" and 1³/₈" standard duty steel doors, together with frames and accessories. They are intended to be standard items not subject to variations.

A250.10-1998 (R2004)

Test Procedure and Acceptance Criteria for – Prime Painted Steel Surfaces for Steel Doors and Frames
Procedures for the selection of material, chemical preparation, painting, testing and evaluation of prime painted steel surfaces for steel doors and frames.

A250.11-2001

Recommended Erection Instructions for Steel Frames
This document includes information in respect to storage of frames on the jobsite, grouting and back painting of frames and assembly of frames. It contains instructions in respect to bracing frames before wall construction and the installation of frames in masonry, steel stud wall construction, wood stud wall construction and drywall construction.

A250.13-2003

Testing and Rating of Severe Windstorm Resistant Components for Swinging Door Assemblies
This standard provides procedures for testing and establishing load ratings (design load in pounds per square foot or pounds force) for components of exterior swinging door assemblies. It is the intent of this document to test the protection of openings during severe windstorm conditions, such as a hurricane, that produces sustained wind speeds or gusts in a range of 110 to 150 miles per hour as defined by ASCE 7-02. It is not intended to simulate wind forces generated by tornadoes.

ANSI Technical publications

Listed on this page are the current Technical publications available from the American National Standards Institute.

Free downloads of these documents are available from SDI's Website:

<http://www.steeldoor.org>

Handing procedures diagrams

To determine the hand of a door, view the door from the outside (the side that hinges are on is the hand of the door).

- If the door swings away from the viewer, the hand is regular hand, i.e., right or left hand.
- If the door swings to the viewer, the door is reverse swing, i.e., right hand reverse swing or left hand reverse swing.

All Steelcraft Doors and Frames are handed according to the following chart::

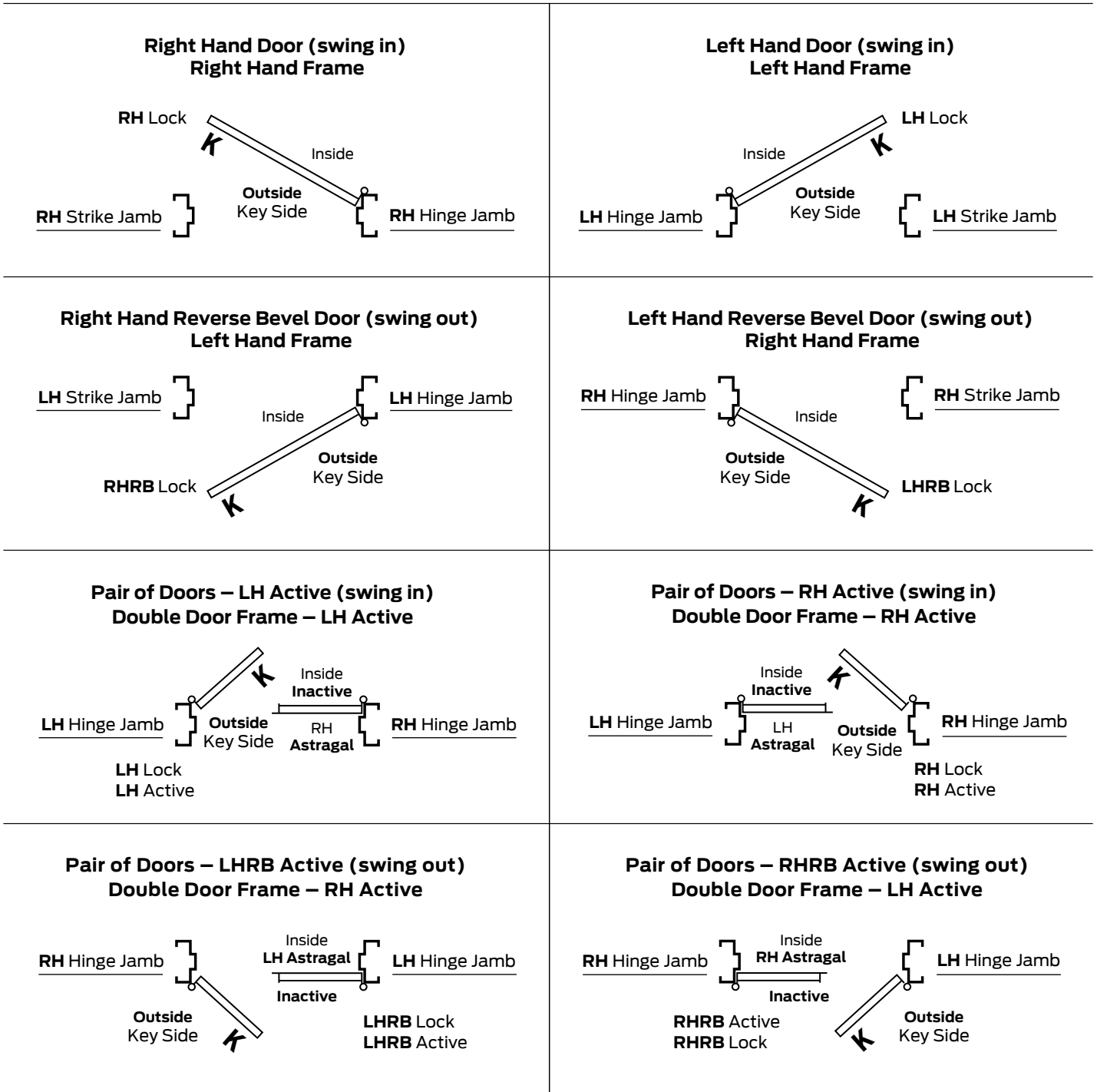

K - indicates Key side of the active door

Frame nomenclature

Steelcraft frames are described and marked with easy to follow product identification nomenclature. The markings identify the frames by frame series, gauge (decimal and metric), fire rating, door thickness, overall depth, door opening height/width, hardware preps, component and handing.

The following is a brief guide to the nomenclature used by Steelcraft: **F 16 UL 4 5 3/4" 70 SJ R ASA**

Notes:

1. The nomenclature designation shown on this page is for education, example and reference only.
2. Refer to the individual Technical Data Manual sheets to develop options related to the specific frame series.
3. Refer to the hardware section of this manual for preps and nomenclature not covered on this sheet.

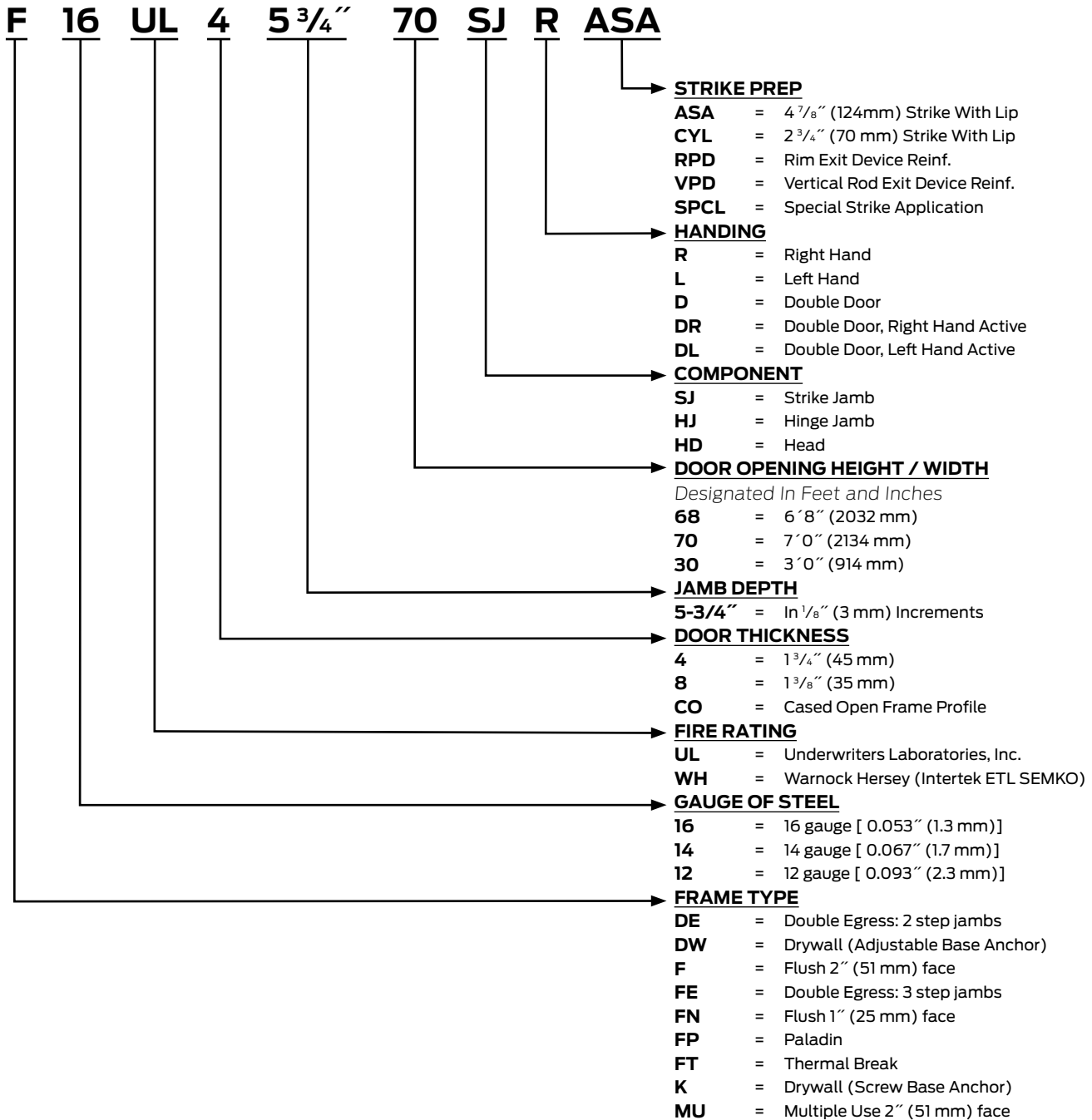

Door nomenclature

Steelcraft doors are described and marked with easy to follow product identification nomenclature. The markings identify the doors by door series, gauge (decimal and metric), fire rating, door thickness, width, height, glass design, hand and lock preps.

The following is a brief guide to the nomenclature used by Steelcraft: **L 18 UL 4 30 70 FR 61L**



3 Hinges (1 1/2 Pair)

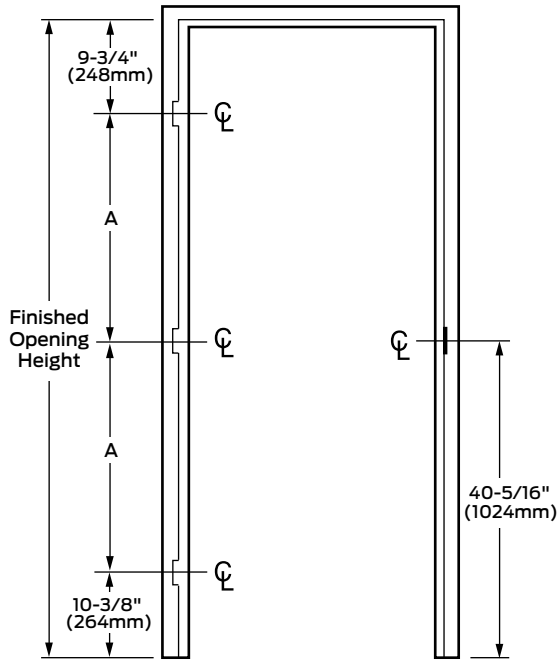

TYPICAL FRAME ELEVATION

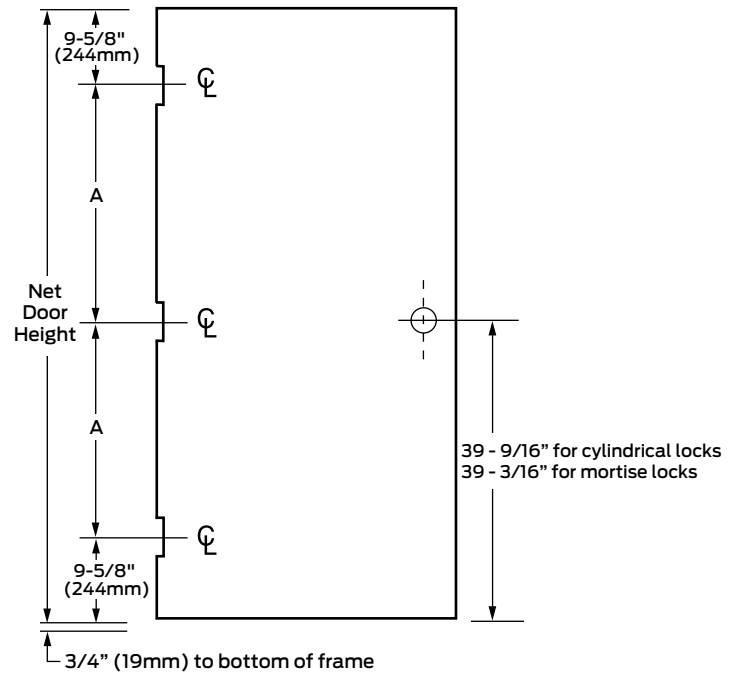

TYPICAL DOOR ELEVATION

Typical Hardware Preps: Table 1

Door opening height	Dimension "A"
6'8" (2032mm)	29-15/16" (760mm)
7'0" (2134mm)	31-15/16" (811mm)
7'2" (2184mm)	32-15/16" (837mm)
7'6" (2286mm)	34-15/16" (887mm)

Notes

- 3 hinges (1-1/2 pair) are standard on 6'8", 7'0", 7'2", and 7'6" openings
- Steelcraft standard locations:** hardware preps (hinge and lock) with standard 3/4" undercut are located as illustrated above and as noted in Table 1.
- Special door undercuts:** hardware locations shown from the bottom of the door will be adjusted accordingly. Locations will be held from the top of the door.
- Special door heights:** special door heights are available. Dimension "A" will vary accordingly.
- Refer to the Hardware section of this manual for all hardware locations and most prep details.

4 Hinges (2 Pair)

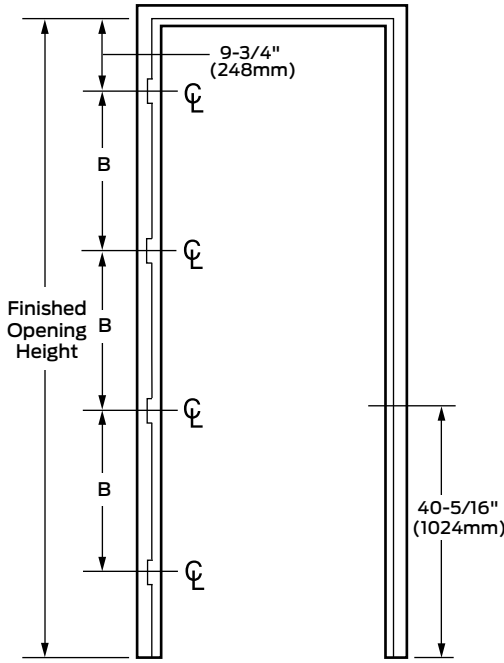

TYPICAL FRAME ELEVATION

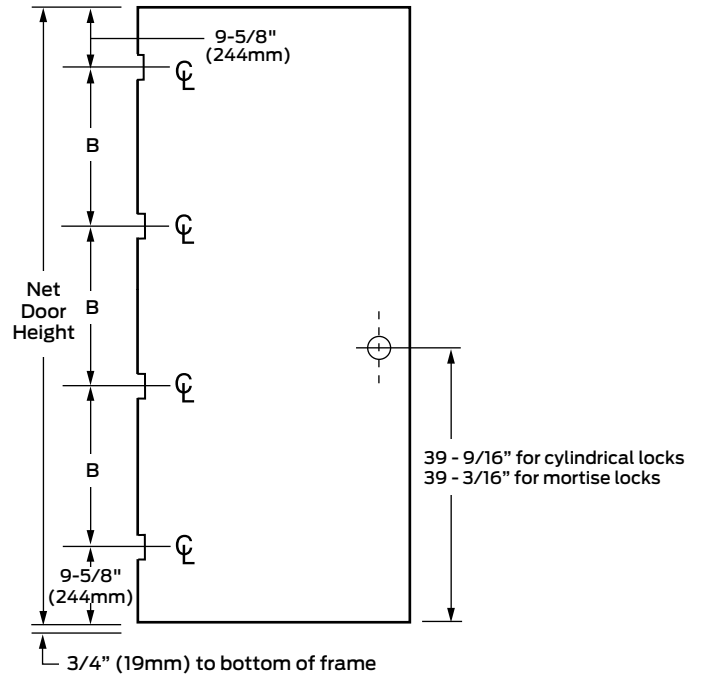

TYPICAL DOOR ELEVATION

Typical Hardware Preps: Table 2

Door opening height	Dimension "B"
6'8" (2032mm)	19-61/64" (507mm)
7'0" (2134mm)	21-19/64" (541mm)
7'2" (2184mm)	21-61/64" (558mm)
7'6" (2286mm)	23-19/64" (592mm)
7'8" (2337mm)	23-61/64" (608mm)
7'10" (2388mm)	24-5/8" (625mm)
8'0" (2438mm)	25-19/64" (643mm)
8'2" (2489mm)	25-61/64" (659mm)
8'4" (2540mm)	26-5/8" (676mm)
8'6" (2591mm)	27-19/64" (693mm)
8'8" (2642mm)	27-61/64" (710mm)
8'10" (2692mm)	28-5/8" (727mm)
9'0" (2743mm)	29-19/64" (744mm)
9'2" (2794mm)	29-61/64" (761mm)
9'4" (2845mm)	30-5/8" (778mm)
9'6" (2896mm)	31-19/64" (795mm)
9'8" (2946mm)	31-61/64" (812mm)
9'10" (2997mm)	32-5/8" (829mm)
10'0" (3048mm)	33-19/64" (846mm)

Notes

1. 4 hinges (2 pair) are standard on openings over 7'6" in height and up to and including 10'0" in height.
2. **Steelcraft standard locations:** hardware preps (hinge and lock) with standard 3/4" undercut are located as illustrated above and as noted in Table 2.
3. **Special door undercuts:** hardware locations shown from the bottom of the door will be adjusted accordingly. Locations will be held from the top of the door.
4. **Special door heights:** special door heights are available. Dimension "B" will vary accordingly.
5. Refer to the Hardware section of this manual for all hardware locations and most prep details.

5 Hinges (2 1/2 Pair)

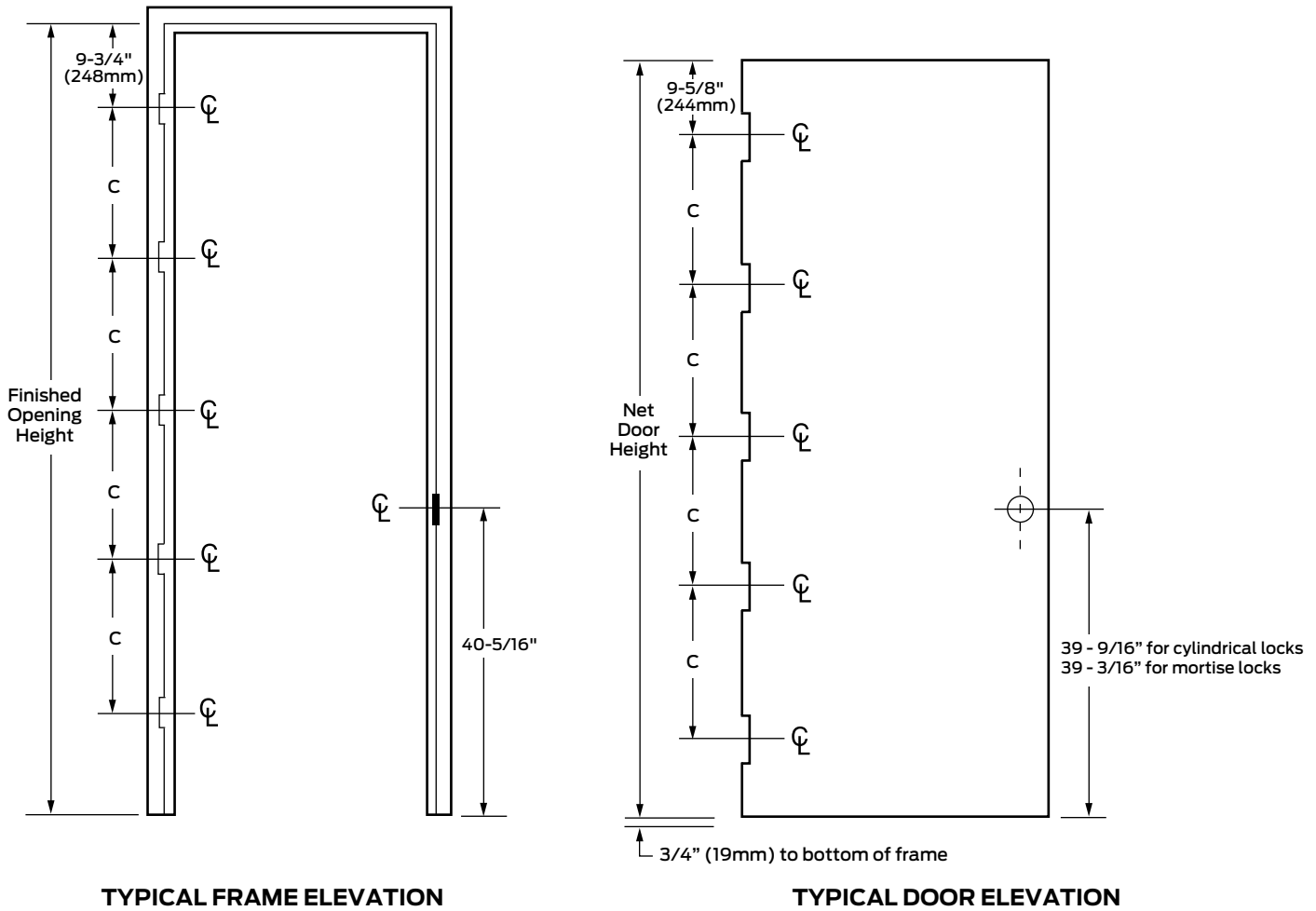

Typical Hardware Preps: Table 3

Door opening height	Dimension "C"
10' 2" (3049mm)	25-15/32" (647mm)
10' 4" (3154mm)	25-31/32" (660mm)
10' 6" (3200mm)	26-15/32" (672mm)
10' 8" (3251mm)	26-31/32" (685mm)
10' 10" (3302mm)	27-15/32" (698mm)
11' 0" (3353mm)	27-31/32" (710mm)

Notes

- 5 hinges (2-1/2 pair) are standard on openings over 10' 0" in height.
- Steelcraft standard locations:** hardware preps (hinge and lock) with standard 3/4" undercut are located as illustrated above and as noted in Table 3.
- Special door undercuts:** hardware locations shown from the bottom of the door will be adjusted accordingly. Locations will be held from the top of the door.
- Special door heights:** special door heights are available. Dimension "C" will vary accordingly.
- Refer to the Hardware section of this manual for all hardware locations and most prep details.

Dutch

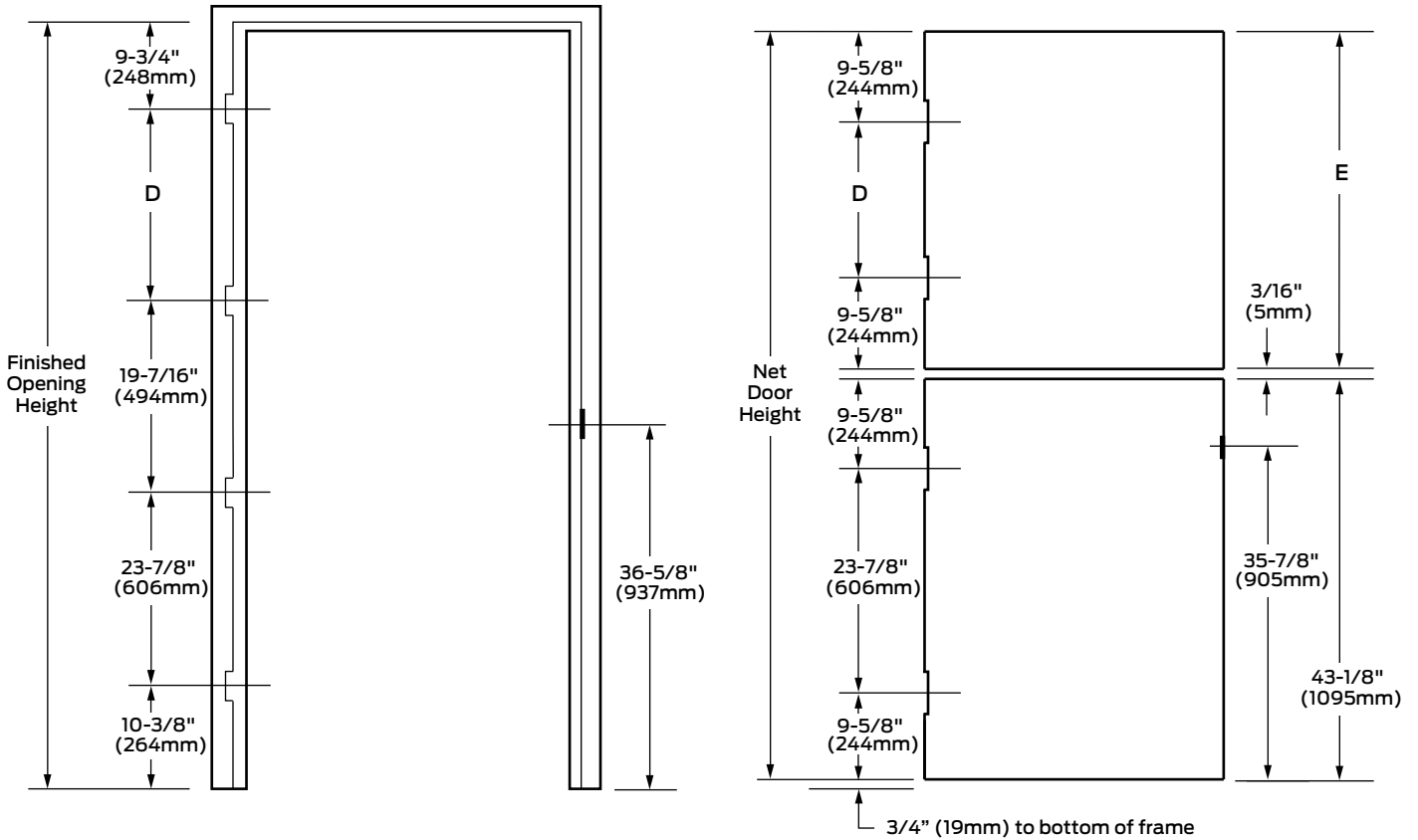

DUTCH DOOR ELEVATION

Typical Hardware Preps: Table 4

Door opening height	Dimension "D"	Dimension "E"
6'8" (2032mm)	16-9/16" (421mm)	35-13/16" (910mm)
7'0" (2134mm)	20-9/16" (522mm)	39-13/16" (1011mm)
7'2" (2184mm)	22-9/16" (573mm)	41-13/16" (1062mm)

Notes

1. 4 hinges (2 pair) are standard on dutch door openings.
2. **Steelcraft standard locations:** hardware preps (hinge and lock) with standard 3/4" undercut are located as illustrated above and as noted in Table 4.
3. **Special door undercuts:** hardware locations shown from the bottom of the door will be adjusted accordingly. Locations will be held from the top of the door.
4. **Special door heights:** special door heights are available. Dimensions "D and E" will vary accordingly.
5. **Fire Rated dutch doors:** additional locking hardware is required. Refer to the Fire Rated section of this manual.
6. Refer to the Hardware section of this manual for all hardware locations and most prep details.

Comparative hinge and strike locations

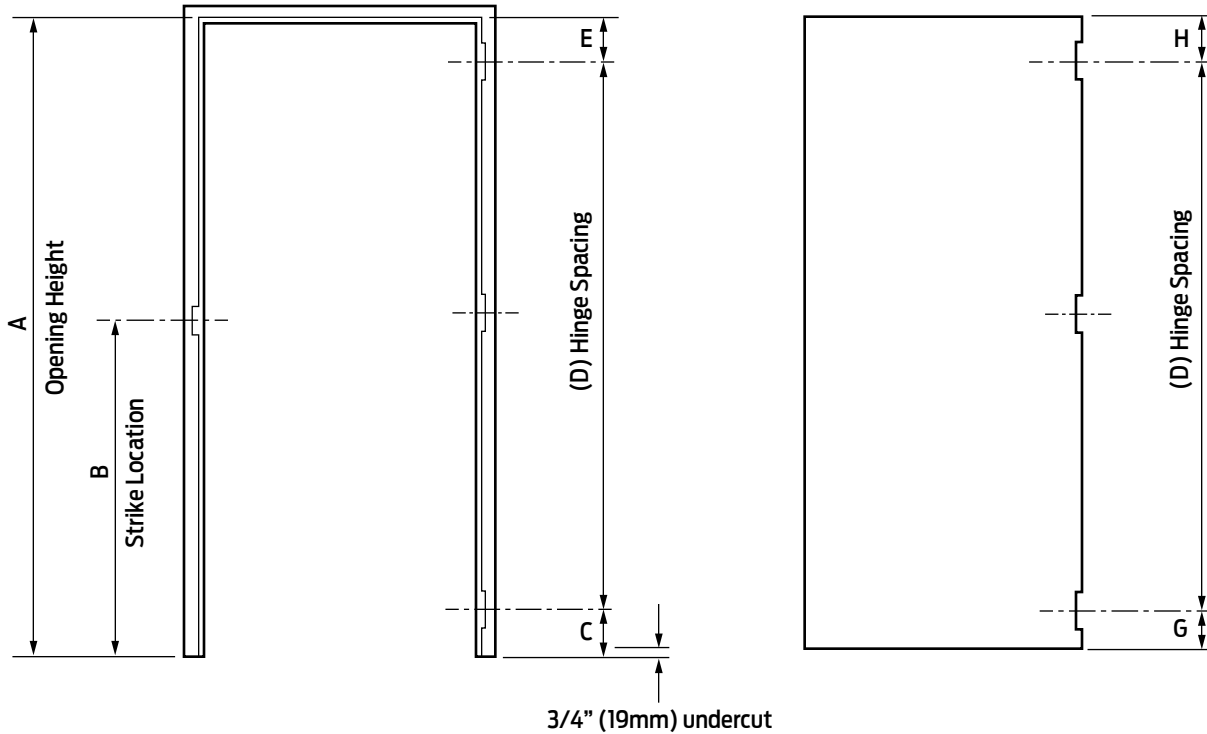

Notes

- A. See page 19 for foot/inch Comparative Hinge and Strike Locations for 1-3/4" Doors and Frames with 4-1/2" x 4-1/2" Hinges.
- B. See page 20 for metric Comparative hinge and strike locations for 45mm Doors and Frames with 114mm x 114mm Hinges.
- C. Dimensions for hinge and strike locations of the SDI Manufacturers shown on pages 19 and 20 are to the centerline of the preparation.

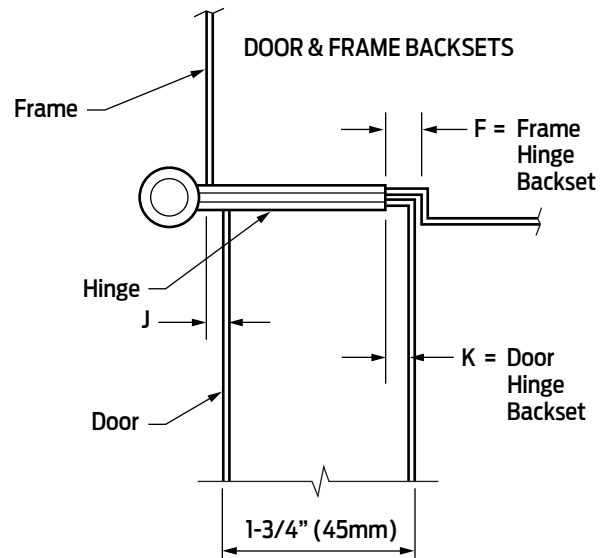

Comparative hinge and strike locations for 1 3/4" Doors and frames with 4 1/2" x 4 1/2" hinges

Manufacturer	A	B	C	D	E	F	G	H	J	K	
	Frame						Door				
	Height	Strike	Bottom hinge	Hinge spacing	Top hinge	Hinge backset	Bottom hinge	Top hinge	Inset (reveal)	Hinge backset	
℄ from floor							℄ to ℄	℄ from underside of head			℄ to door bottom
Steelcraft	6'8"	40 5/16"	10 3/8"	2 @ 29 15/16"	9 3/4"	5/16"	9 5/8"	9 5/8"	1/8"	1/4"	
	7'0"			2 @ 31 15/16"							
	7'2"			2 @ 32 15/16"							
	7'10"			3 @ 24 5/8"							
	8'0"			3 @ 25 19/64"							
Amweld	6'8"	40 5/16"	10 3/8"	2 @ 29 15/16"	9 3/4"	5/16"	9 5/8"	9 5/8"	1/16"	3/16"	
	7'0"		2 @ 31 15/16"	11 5/8"							
	7'2"		12 3/8"	2 @ 31 15/16"			7 9/16"				
	7'10"		8 5/16"	3 @ 25 15/16"			9 9/16"				
	8'0"		10 5/16"	3 @ 25 15/16"							
Ceco	6'8"	41 13/16"	9"	2 @ 31"	9"	5/16"	8 1/4"	8 7/8"	1/8"	1/4"	
	7'0"			2 @ 33"							
	7'2"			2 @ 34"							
	7'10"			3 @ 25 21/64"							
	8'0"			3 @ 26"							
Curries	6'8"	40"	12 1/4"	2 @ 30 1/4"	7 1/4"	5/16"	11 5/8"	7 1/8"	1/8"	1/4"	
	7'0"			2 @ 32 1/4"			11 1/2"				
	7'2"			2 @ 33 1/4"			11 5/8"				
	7'10"			12 1/8"			3 @ 24 7/8"				
	8'0"			12 1/4"			3 @ 25 1/2"				
Deansteel	6'8"	40 5/16"	12 1/4"	2 @ 30 1/4"	7 1/4"	5/16"	11 1/2"	7 1/8"	1/8"	1/4"	
	7'0"			2 @ 32 1/4"							
	7'2"			2 @ 33 1/4"							
	7'10"			24 7/8" 24 3/4" 24 7/8"							
	8'0"			3 @ 25 1/2"							
Mesker	6'8"	40 5/16"	12 1/4"	2 @ 30 1/4"	7 1/4"	5/16"	11 1/2"	7 1/8"	1/8"	1/4"	
	7'0"			2 @ 32 1/4"			9 1/2"				
	7'2"			2 @ 33 1/4"			11 1/2"				
	7'10"			10 1/4"			3 @ 25 1/2"				
	8'0"			12 1/4"			3 @ 25 1/2"				
Pioneer	6'8"	38"	12 1/4"	2 @ 30 1/4"	7 1/4"	5/16"	11 5/8"	7 1/8"	3/32"	7/32"	
	7'0"			2 @ 32 1/4"			11 11/16"				
	7'2"			2 @ 33 1/4"			11 5/8"				
	7'10"			12 5/16"			3 @ 24 13/16"				
	8'0"			12 1/4"			3 @ 25 1/2"				
Republic	6'8"	40 5/16"	12 1/4"	2 @ 30 1/4"	7 1/4"	5/16"	11 1/2"	7 1/8"	1/8"	1/4"	
	7'0"			2 @ 32 1/4"							
	7'2"			2 @ 33 1/4"							
	7'10"			3 @ 24 53/64"							
	8'0"			3 @ 25 1/2"							
Security metal products	6'8"	40 5/16"	12 1/4"	2 @ 30 1/4"	7 1/4"	3/8"	11 1/2"	7 1/8"	1/16"	1/4"	
	7'0"			2 @ 32 1/4"							
	7'2"			2 @ 33 1/4"							
	7'10"			3 @ 24 53/64"							
	8'0"			3 @ 25 1/2"							

All dimensions are current at the time of publication. Refer to SDI-129 for updated dimensions.

Comparative hinge and strike locations for 45mm doors and frames with 114mm x 114mm hinges (metric dimensions)

Manufacturer	A	B	C	D	E	F	G	H	J	K	
	Frame						Door				
	Height	Strike	Bottom hinge	Hinge spacing	Top hinge	Hinge backset	Bottom hinge	Top hinge	Inset (reveal)	Hinge backset	
€ from floor											€ to €
Steelcraft	2032 mm	1024 mm	264 mm	2 @ 760 mm	248 mm	8 mm	244 mm	244 mm	3.2 mm	6.4 mm	
	2134 mm			2 @ 811 mm							
	2184 mm			2 @ 837 mm							
	2388 mm			3 @ 625 mm							
	2438 mm			3 @ 643 mm							
Amweld	2032 mm	1024 mm	264 mm	2 @ 760 mm	248 mm	8 mm	244 mm	244 mm	1.6 mm	4.7 mm	
	2134 mm		264 mm	2 @ 811 mm			244 mm				
	2184 mm		314 mm	2 @ 811 mm			295 mm				
	2388 mm		211 mm	3 @ 643 mm			192 mm				
	2438 mm		253 mm	3 @ 643 mm			243 mm				
Ceco	2032 mm	1062 mm	229 mm	2 @ 787 mm	229 mm	8 mm	210 mm	225 mm	3.2 mm	6.4 mm	
	2134 mm			2 @ 838 mm							
	2184 mm			2 @ 864 mm							
	2388 mm			3 @ 643 mm							
	2438 mm			3 @ 660 mm							
Curries	2032 mm	1016 mm	311 mm	2 @ 768 mm	184 mm	8 mm	295 mm	181 mm	3.2 mm	6.4 mm	
	2134 mm		311 mm	2 @ 819 mm			295 mm				
	2184 mm		311 mm	2 @ 845 mm			295 mm				
	2388 mm		308 mm	3 @ 632 mm			292 mm				
	2438 mm		311 mm	3 @ 648 mm			295 mm				
Deansteel	2032 mm	1024 mm	311 mm	2 @ 768 mm	184 mm	8 mm	292 mm	181 mm	3.2 mm	6.4 mm	
	2134 mm			2 @ 819 mm							
	2184 mm			2 @ 845 mm							
	2388 mm			632 mm - 629 mm - 632 mm							
	2438 mm			3 @ 648 mm							
Mesker	2032 mm	1024 mm	311 mm	2 @ 768 mm	184 mm	8 mm	292 mm	181 mm	3.2 mm	6.4 mm	
	2134 mm		311 mm	2 @ 819 mm			292 mm				
	2184 mm		311 mm	2 @ 845 mm			292 mm				
	2388 mm		260 mm	3 @ 648 mm			241 mm				
	2438 mm		311 mm	3 @ 648 mm			292 mm				
Pioneer	2032 mm	965 mm	311 mm	2 @ 768 mm	184 mm	8 mm	295 mm	181 mm	2.4 mm	5.6 mm	
	2134 mm		311 mm	2 @ 819 mm			295 mm				
	2184 mm		311 mm	2 @ 845 mm			295 mm				
	2388 mm		313 mm	3 @ 630 mm			297 mm				
	2438 mm		311 mm	3 @ 648 mm			295 mm				
Republic	2032 mm	1024 mm	311 mm	2 @ 768 mm	184 mm	8 mm	292 mm	181 mm	3.2 mm	6.4 mm	
	2134 mm			2 @ 819 mm							
	2184 mm			2 @ 845 mm							
	2388 mm			3 @ 631 mm							
	2438 mm			3 @ 648 mm							
Security metal products	2032 mm	1024 mm	311 mm	2 @ 768 mm	184 mm	10 mm	292 mm	181 mm	1.6 mm	6.4 mm	
	2134 mm			2 @ 819 mm							
	2184 mm			2 @ 845 mm							
	2388 mm			3 @ 630 mm							
	2438 mm			3 @ 648 mm							

All dimensions are current at the time of publication. Refer to SDI-129 for updated dimensions.