



911065-00

5547-F

VON DUPRIN®

Concealed Vertical Rod Exit Device for Metal Doors
UL Listed Fire Exit Hardware

Installation Instructions

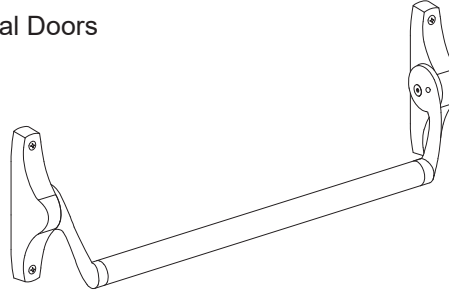

1 Check handing of device. Reverse if necessary.

REVERSING PROCEDURE FOR LOCK STILE CASE

Invert the case and reassemble in order shown (a thru d) with opposite hand lever arm from hinge case.

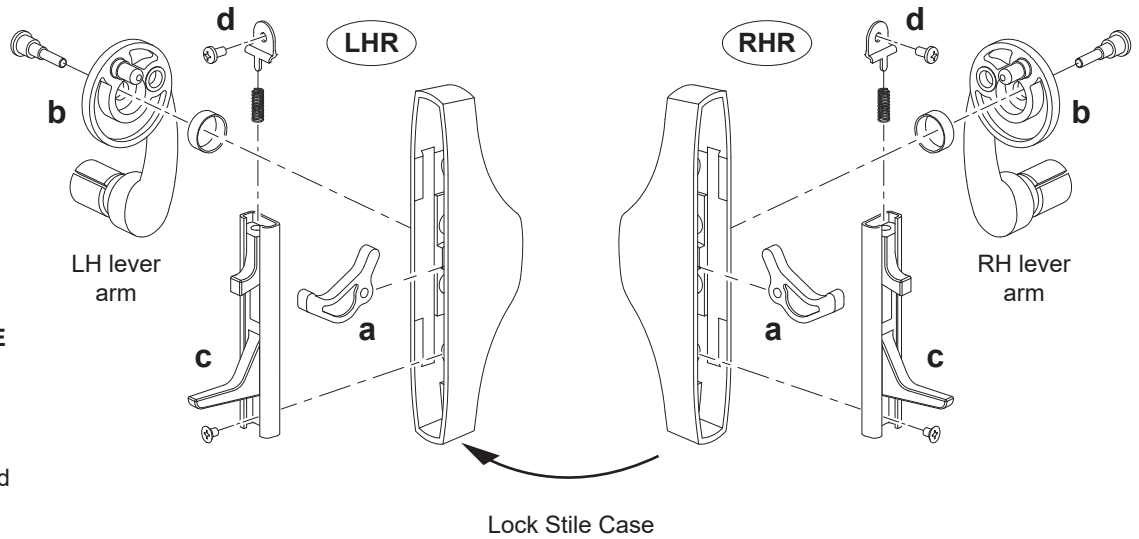

REVERSING PROCEDURE FOR HINGE STILE CASE

Disassemble hinge stile case, rotate parts as shown with spring always at the bottom. Reassemble in order shown (a thru d) with opposite hand lever arm from center case.

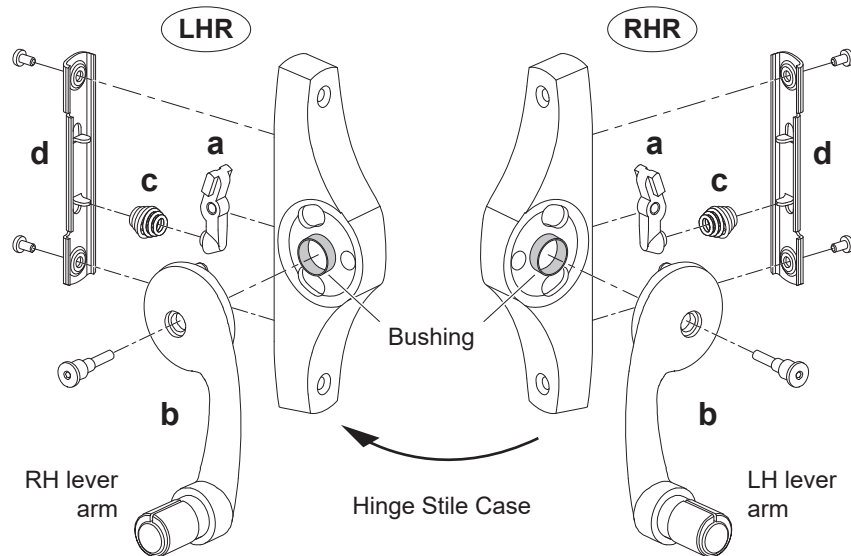

ⓘ When exchanging parts, be certain that one bushing remains on the hub of each case.

2 Prepare door.

- Tape template No. 1 or 2 (page 4), depending on handing of door, to inside face of lock stile. Be sure vertical centerline of device is parallel to edge of door and backset is $2\frac{3}{8}$ ". Be sure horizontal centerline of device is $39\frac{13}{16}$ " to finished floor.
- Prepare door as shown below.

ⓘ This device is for metal door only.

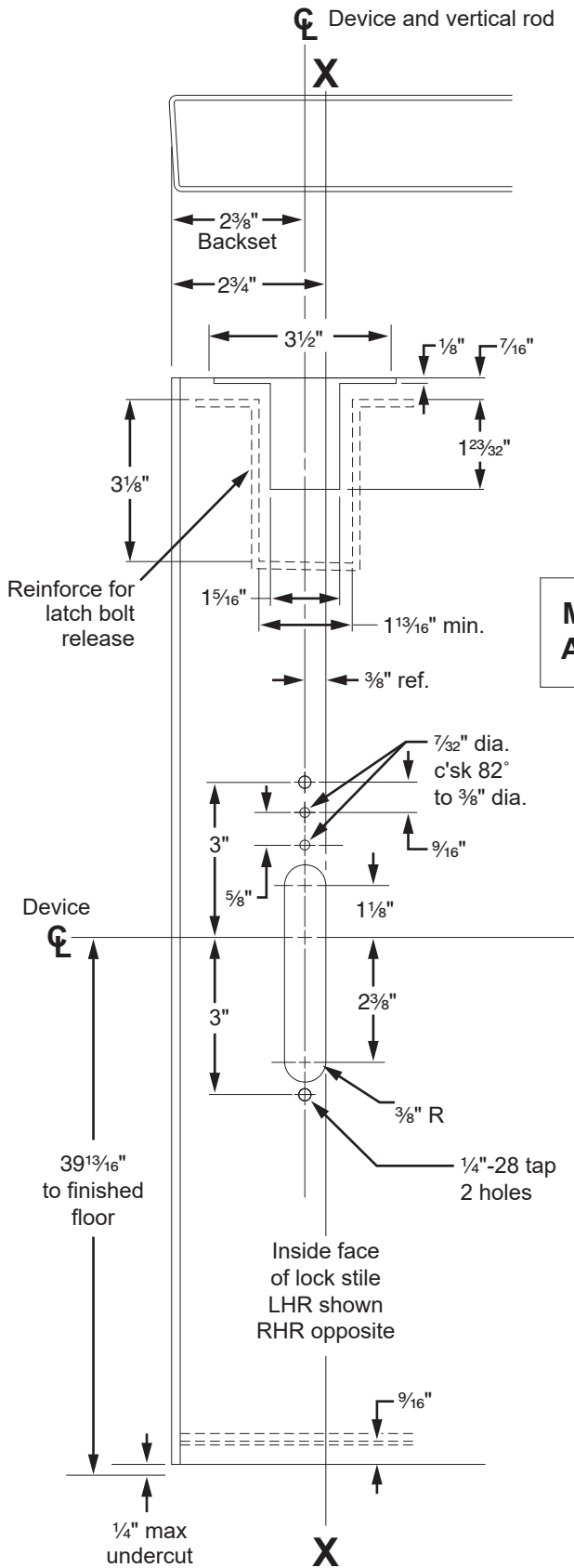

METAL DOOR APPLICATION

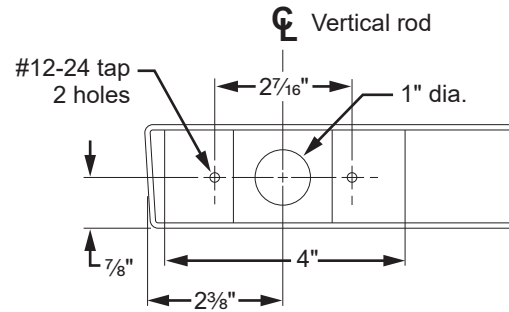

Note - Mortar guard should be provided by frame manufacturer to protect soffit latch bolt assembly

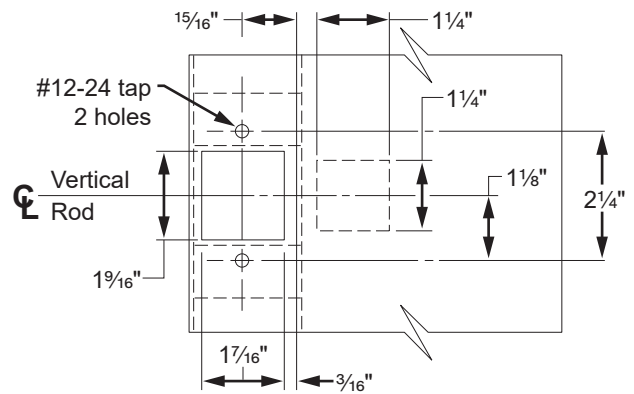
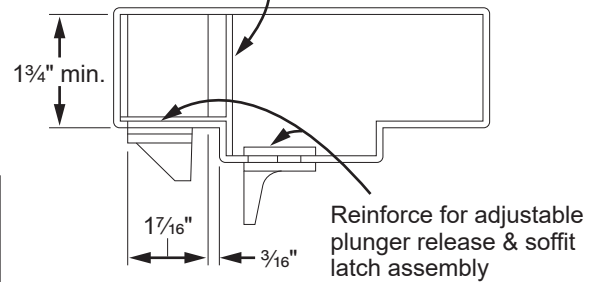

Soffit Frame Reinforcement

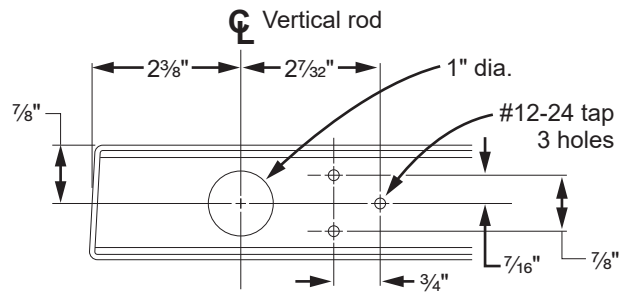

For trim application see directions in trim carton if required

**THIS PAGE
INTENTIONALLY
BLANK**

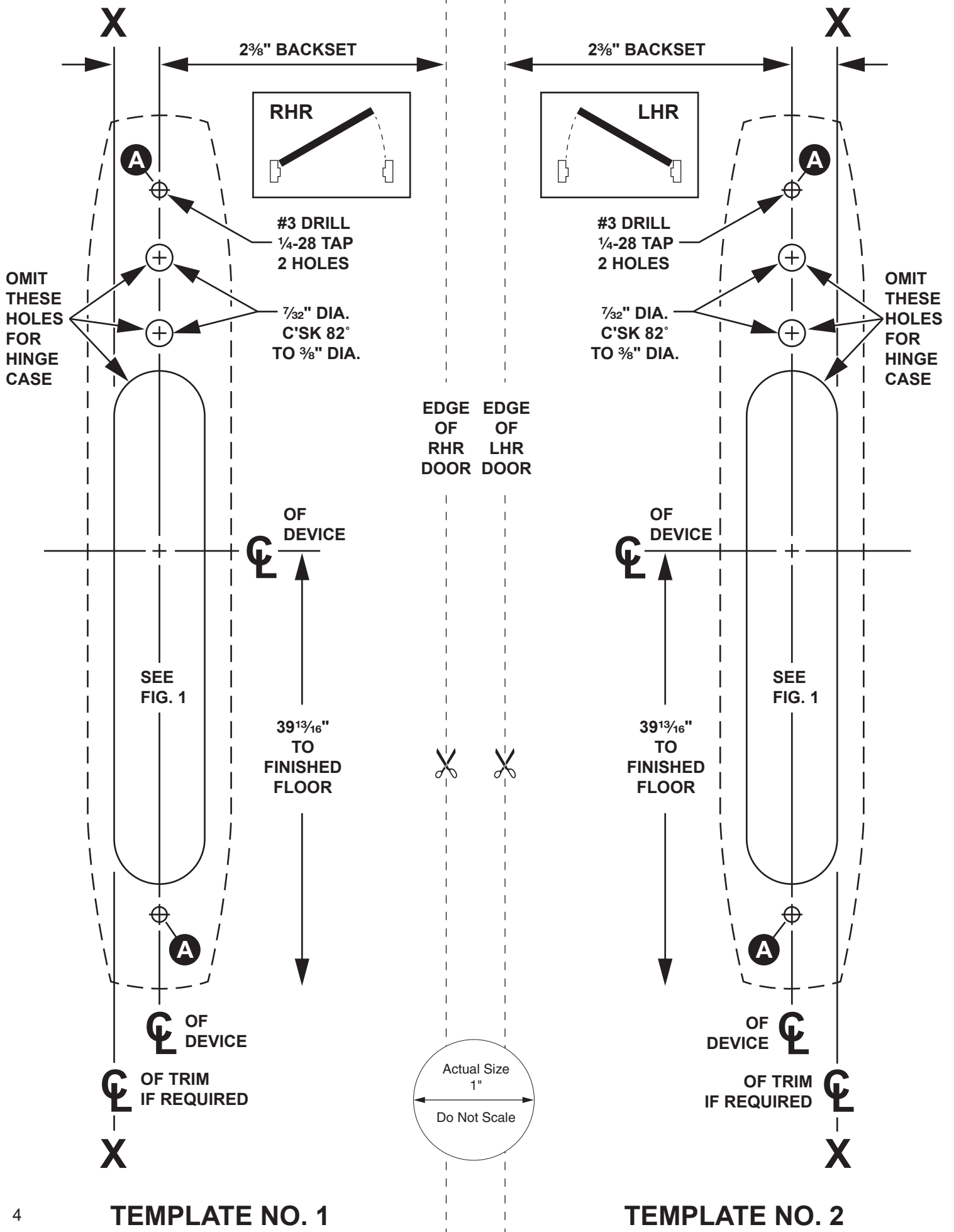

**THIS PAGE
INTENTIONALLY
BLANK**

**THIS PAGE
INTENTIONALLY
BLANK**

3 Assemble top rod.

- i Maximum approved door height for 5547-F devices is 8'0".
 - a. Assemble top rod tube over hex rod. Align hole in tube that corresponds to predrilled height.
 - b. Install rod connector pin using a center punch.

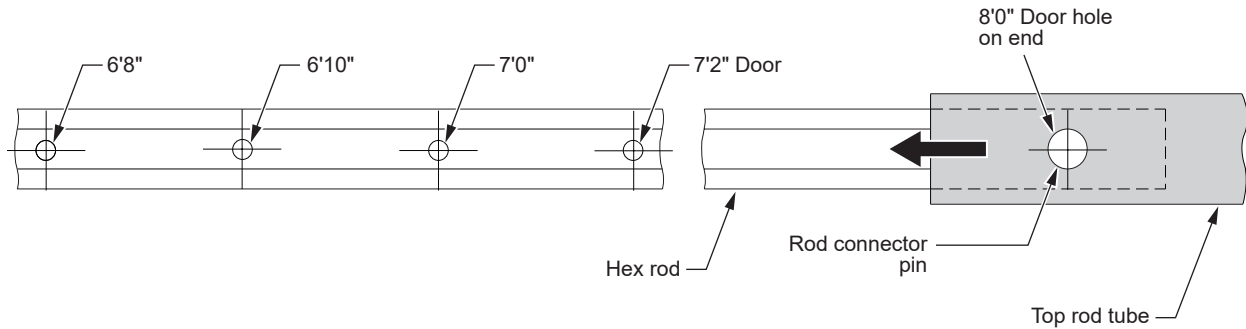

Miscellaneous Door Heights up to 8'0"

- a. Measure door opening height (finished floor to rabbet)
- b. Subtract measured height from 8'0" to get difference
- c. Measure this difference from the 8'0" hole on the hex rod and mark a line.
- d. Assemble top rod tube over hex rod. Align hole in tube with the scribed line.
- e. Mark location of the hole in the tube on the hex rod.
- f. Drill a 3/16" hole thru the hex rod.
- g. Align the holes and install the rod connector pin using a center punch.

Constant Dimension	8'0"
Door Opening Height	- <input type="text"/>

Difference	= <input type="text"/>

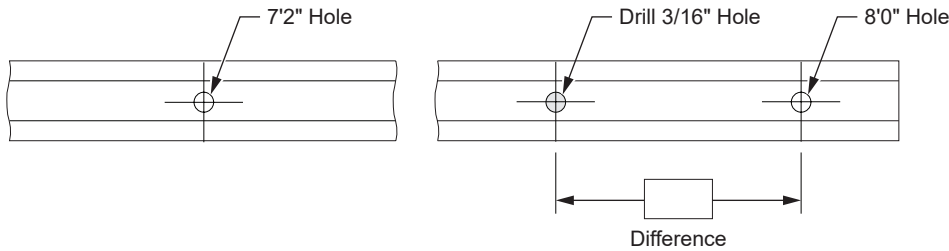

Miscellaneous Door Heights up to 10'0"

- a. Measure door opening height (finished floor to rabbet)
- b. Subtract measured height from 10'0" to get difference
- c. Measure this difference from the 10'0" hole on the hex rod.
- d. Assemble top rod tube over hex rod. Align hole in tube with the scribed line. Cut hex rod if required.
- e. Mark location of the hole in the tube on the hex rod.
- f. Drill a 3/16" hole thru the hex rod.
- g. Align the holes and install the rod connector pin using a center punch.

Constant Dimension	10'0"
Door Opening Height	- <input type="text"/>

Difference	= <input type="text"/>

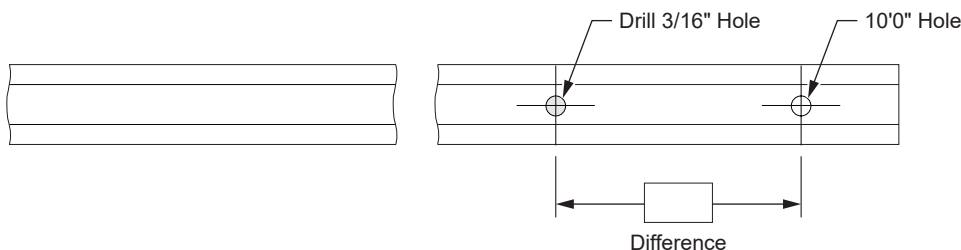

4 Install top rod and latch release.

- ⓘ Lever or thumbturn control rod member is attached to rod in this step. Refer to control instructions.
- Slip top rod and latch release into top door channel cutout. Reference $2\frac{3}{8}$ " to centerline of vertical rods.
 - Be sure latch release is flat on top door channel.
 - Insert rod guide and tighten mounting screws. See Templates 1 and 2 for hole locations.
 - Secure top latch with mounting screws.

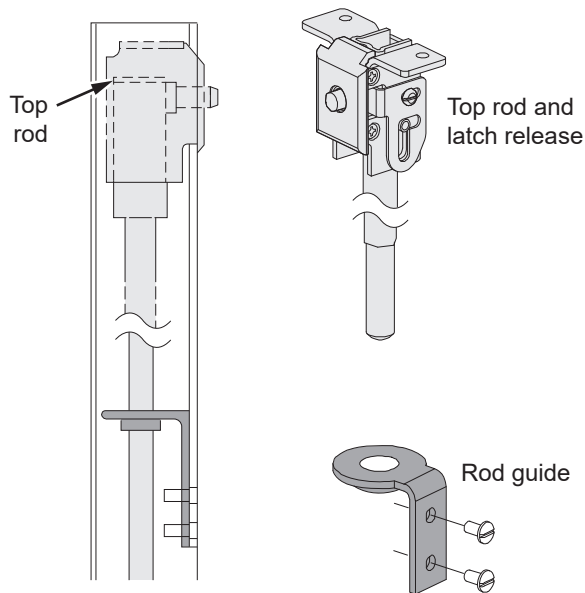

5 Apply outside trim (if required).

- See directions in trim carton. Line "X-X" on trim template corresponds to line "X-X" on device templates 1 and 2 and is parallel to edge of door. Transfer line "X-X" from inside face to outside face of door.
- Prepare outside face of lock stile and apply trim.

6 Install bottom rod and guide.

- ⓘ Do not cut bottom rod.
- Slip bottom rod through hole in bottom door channel.
 - Screw coupling on bottom rod onto top rod.
 - Assemble, then install bottom rod guide with spring pointing toward top of door.

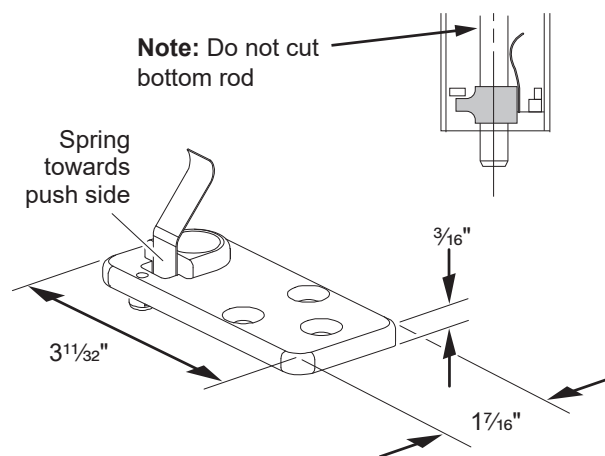
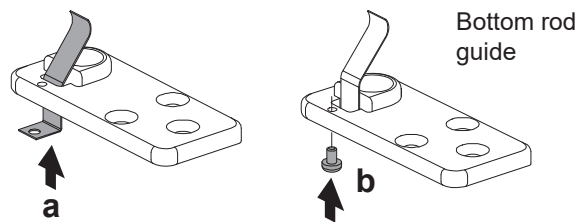

7 Adjust bottom rod.

- Depress top latch release plunger and push top rod toward bottom of door.
- When in latched position, bottom rod must extend $\frac{5}{8}$ " from bottom of door as long as undercut is $\frac{1}{4}$ ".

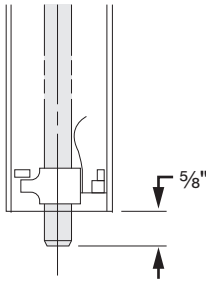

- If necessary rotate coupling to raise or lower bottom rod.

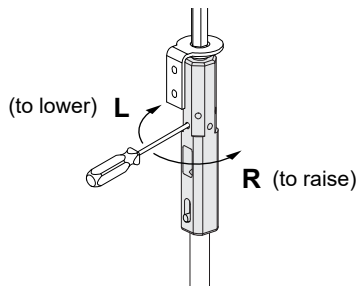

- Be sure top of rectangular hole in coupling is visible at the bottom of rectangular cutout in door.

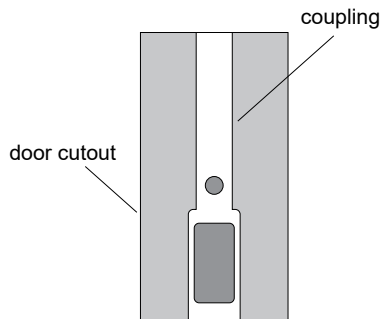

8 Apply lock stile case.

- Attach lock stile case to door using 2 hex studs and the shorter screws in device mounting package 900515.
- Push lever arm to achieve unlatched position. U-shaped top latch release bracket should be flush to $\frac{1}{16}$ " above latch release surface.
- If bottom bolt requires adjustment, remove lock stile case and adjust bottom rod coupling.

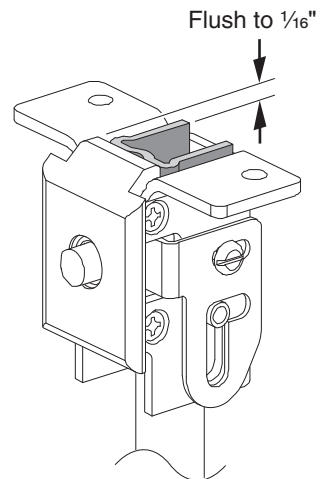
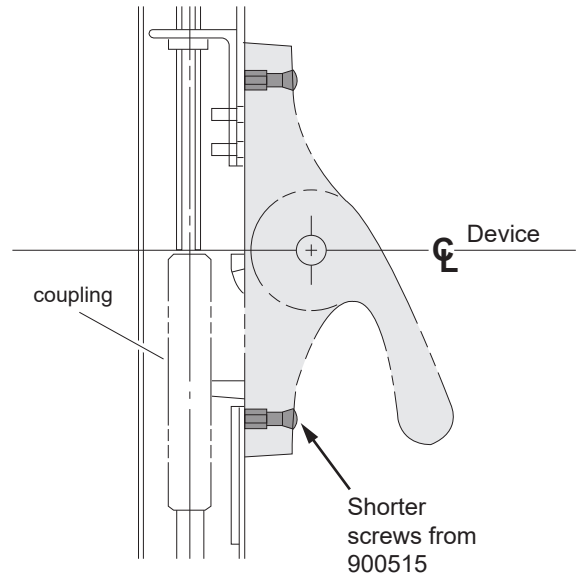

9 Hang door and install sill strike and threshold, if any.

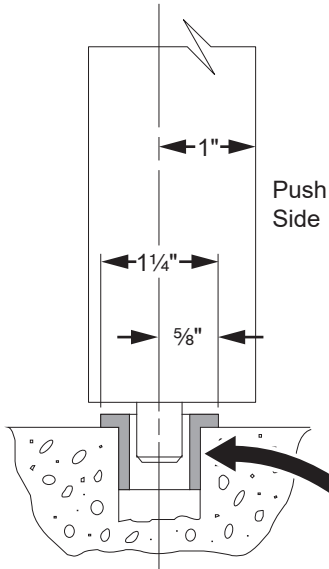

FLAT SILL APPLICATION

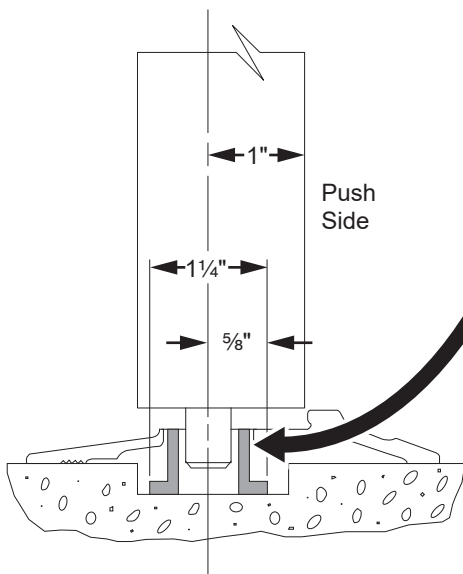
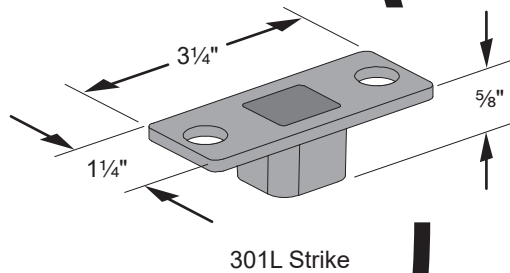

THRESHOLD APPLICATION

i Strike must be inverted and grouted into floor.

10 Install soffit latch bolt.

- a. Block door in open position.
- b. Install latch bolt as shown.

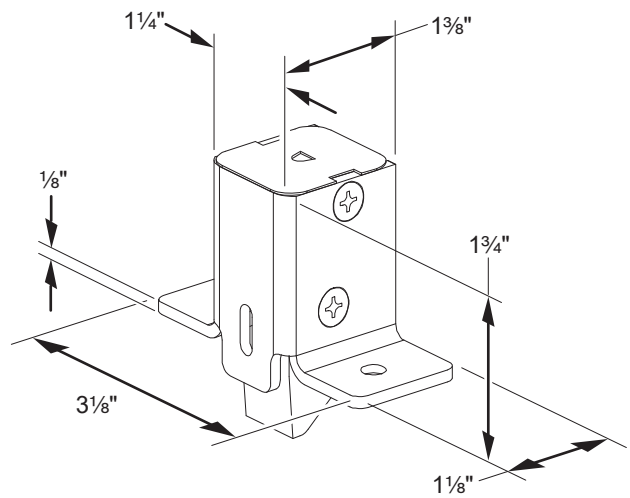
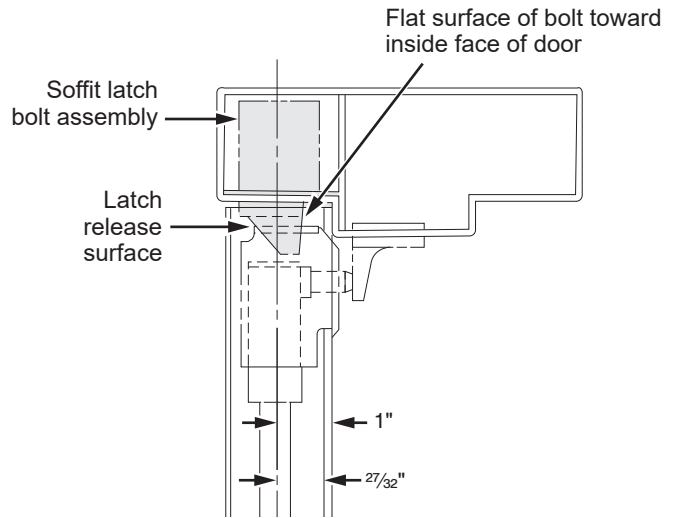

11 Apply plunger release bracket.

- Close door against stop.
- Prepare frame per drawing below for attaching screws.
- Position bracket to depress plunger and allow rods to fall into engaged position.
- Tighten bracket mounting screws.

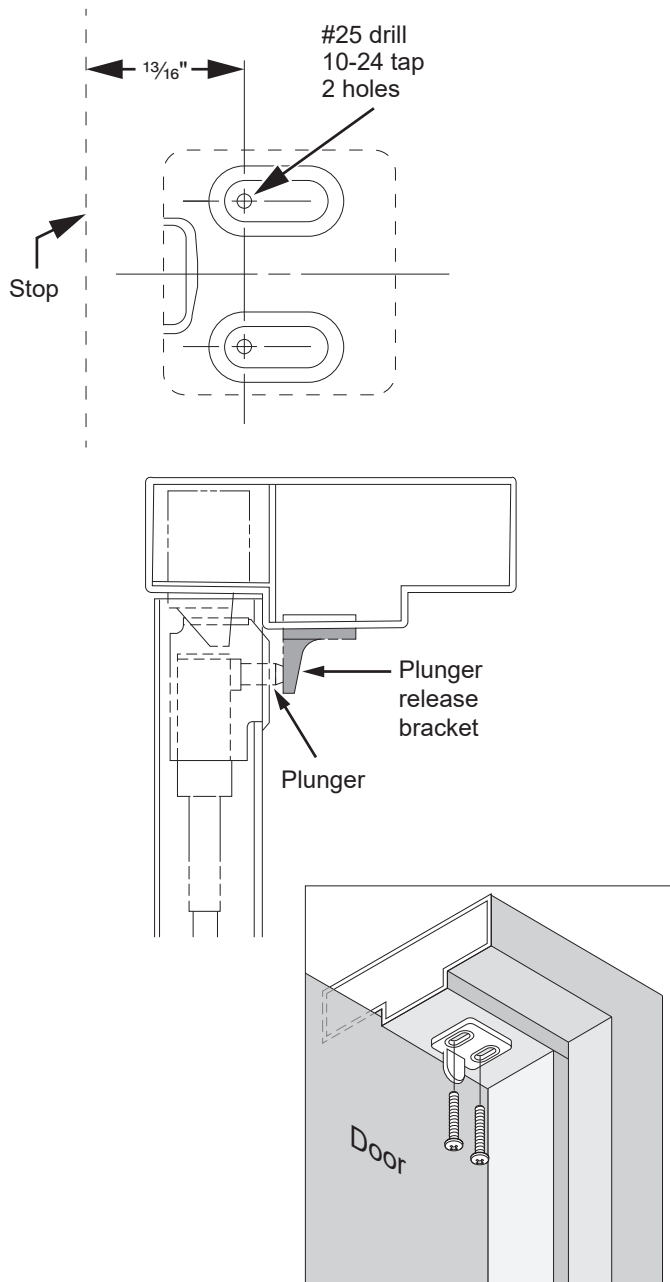

12 Apply hinge stile case and crossbar tube.

- Remove lever arm wedge-tite set screws. Make sure wedges and split rings are installed on lever arms.
- Slip crossbar tube on lock stile and hinge stile lever arms. (See instruction 941009 for cutting crossbar, if necessary.)
- Be sure crossbar is level and hinge stile case is parallel to edge of door and approximately on centerline of exposed stile.
- Using holes in hinge stile case, mark location and prepare door for sex bolts. Drill $1\frac{3}{32}$ " dia. outside and $\frac{3}{8}$ " dia. inside.
- Seat sexbolts in hinge stile of door with a soft hammer to prevent marking of door and sexbolts.
- With crossbar in place, install hinge stile case using 625 sexbolts and $\frac{3}{4}$ " mounting screws from mounting package 900515.
- While depressing crossbar, tighten wedge-tite set screws securely with dog key and screwdriver or equivalent for leverage, and test crossbar for free action. (See instruction 941009.)

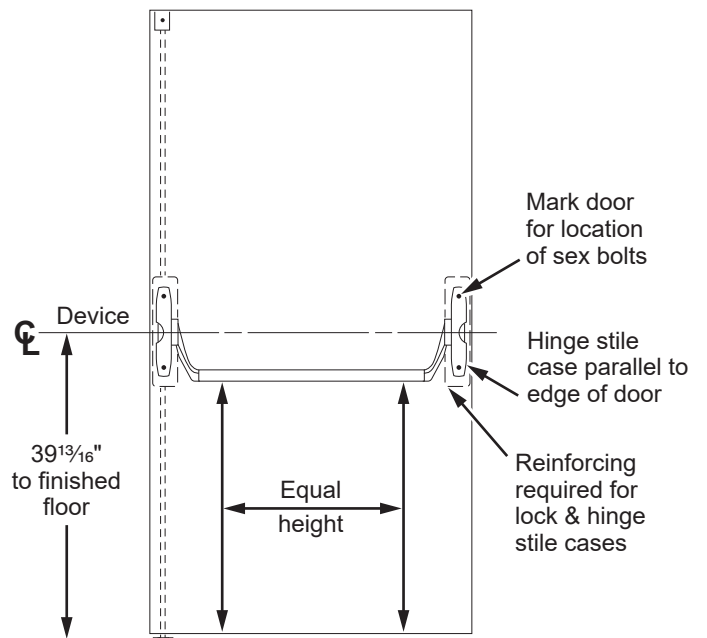



Customer Service

1-877-671-7011 www.allegion.com/us

© Allegion 2019
Printed in U.S.A.
911065-00 Rev. 03/19-e