



941019-00

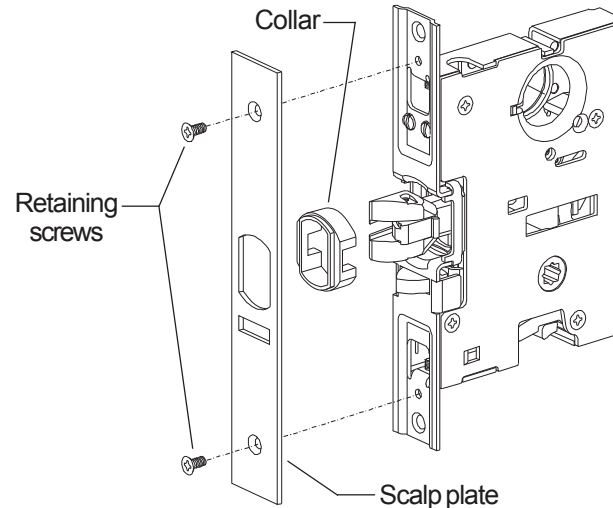
# 7500

# VON DUPRIN®

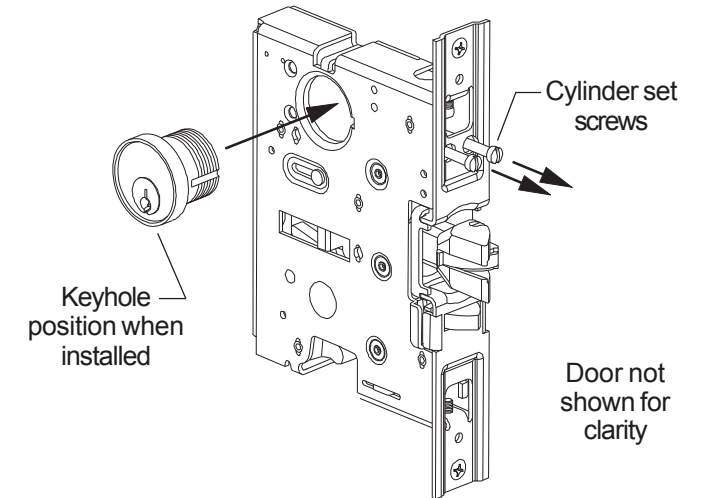
Mortise Lock

Installation Instructions

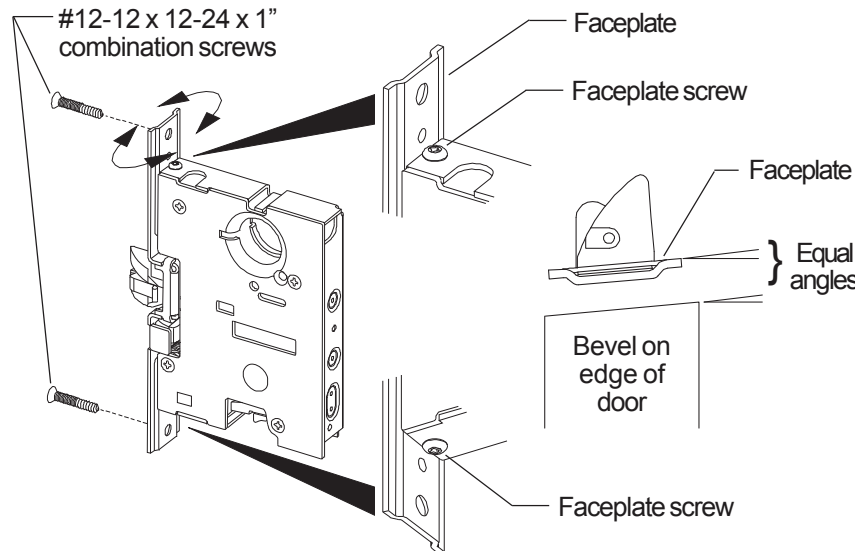
1. Prepare door for device and trim (see their instructions).
2. Prepare door for mortise lock and cylinder (see preparation on other side of these instructions).
3. Adjust faceplate for door bevel (Figure 2):
  - (a) Loosen top and bottom faceplate screws.
  - (b) Pivot faceplate to match door bevel.
  - (c) Tighten top and bottom faceplate screws.
4. Install mortise lock into door with two #12-12 x 12-24 x 1" combination screws.
5. Install trim, if required (see trim instructions).
6. If using outside cylinder (Figure 3):
  - (a) Back out cylinder set screws enough to clear cylinder mounting hole.
  - (b) Thread cylinder into mortise lock through hole in outside face of door.
  - (c) Tighten the cylinder set screw that is closest to outside face of door. Remove the other cylinder set screw.
7. Rotate latch bolt so flat side faces exit direction (Figure 4).
8. Install collar, scalp plate, and scalp plate retaining screws (Figure 1).



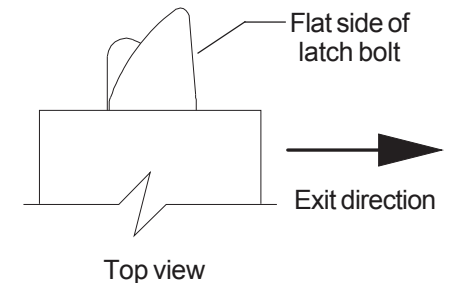
**Figure 1**



**Figure 3**

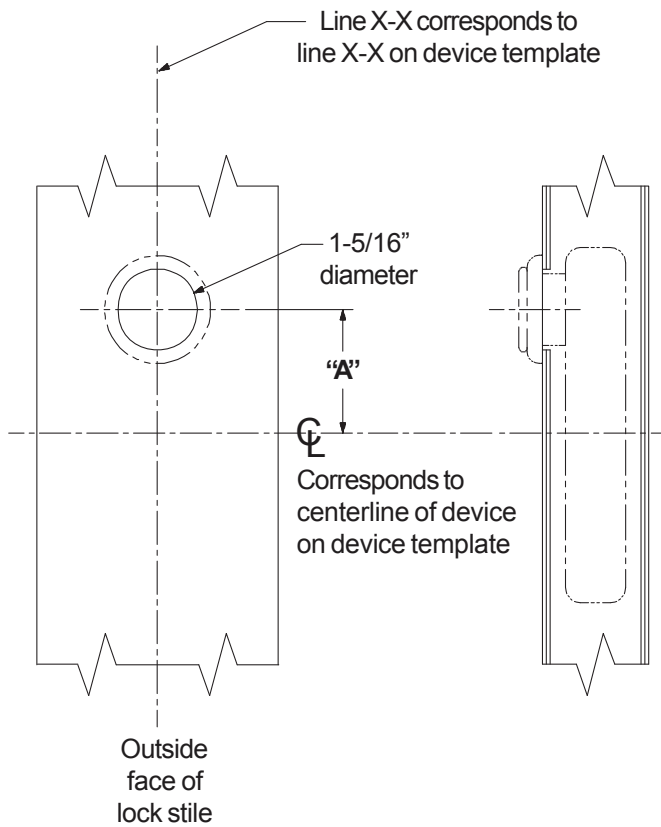


**Figure 2**



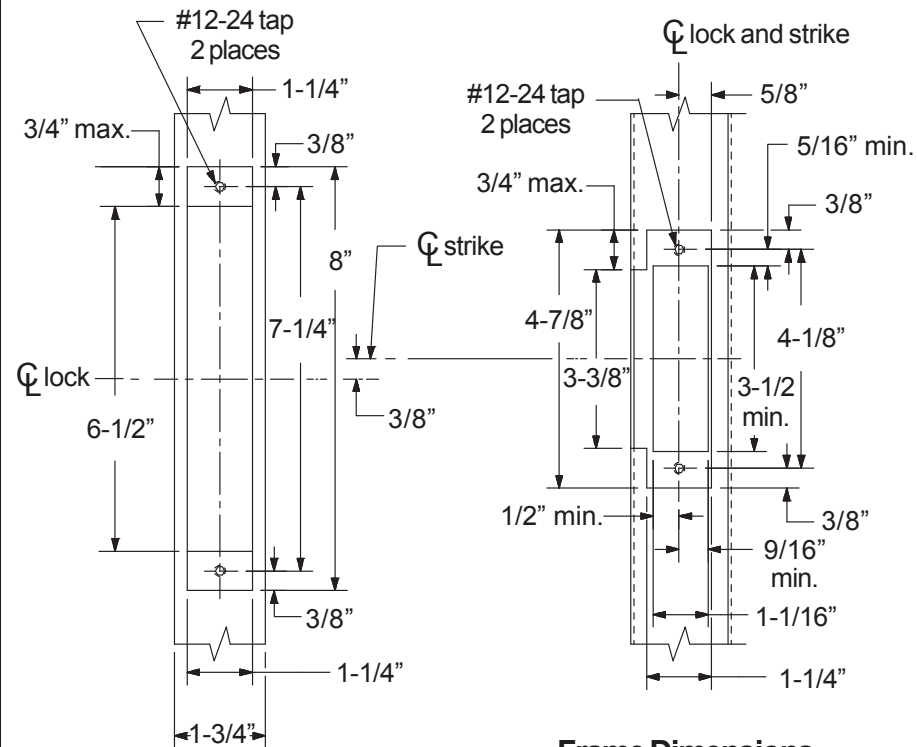
**Figure 4**

## DOOR PREPARATION FOR MORTISE CYLINDER



Device Application Schedule	
Device	Dim. "A"
55 mortise	2"
88 mortise	2"
98/99 mortise	2-7/32"
94/95 mortise	10-3/8"

## METAL DOOR PREPARATION FOR MORTISE LOCK



Frame Dimensions

Door Dimensions

## WOOD DOOR PREPARATION FOR MORTISE LOCK

