

# INSTALLATION DIRECTIONS

## BEFORE APPLYING THIS DEVICE

- A. Threshold (if any) must be installed.
- B. Doors must be fitted and hung.
- C. Check that handing of hardware corresponds with handing of door.

## 1. APPLY STRIKE

- A. Tape appropriate strike template to stop.
- B. When Von Duprin Mullion is used apply strike at tapped holes in Mullion. (See illustration 1 or 2)
- C. Vertical rod and rim devices on pairs of doors require 1609J strike. See template No. 30021 for this application.

## 2. PREPARE DOOR

- A. Tape full size template No. 1 or 2, depending on handing of door, to inside face of lock stile. See Device Height Schedule.

**NOTE:** BE SURE CENTERLINE OF LOCK STILE CASE IS PARALLEL TO STOP AND THAT EDGE OF CASE IS 3/16 FROM EDGE OF STRIKE. STRIKE MUST BE SHIMMED OUT IF LOCK CASE IS MOUNTED MORE THAN 3/16 FROM STRIKE.

- B. Prepare door as shown. See Fig. 1 for wood door application, and Fig. 2 for metal door application.

## 3. APPLY OUTSIDE TRIM

- A. See directions in trim carton. Line "X-X" on trim template corresponds to line "X-X" on device template and is parallel to edge of door. Transfer line "X-X" from inside face to outside face of door.
- B. Prepare outside face of lock stile.
- C. Cut off thumbpiece and cylinder tailpiece, if necessary, to extend 5/8 to 3/4 thru door and into device case.
- D. Apply outside trim.

## 4. INSTALL LEVER ARMS

- A. Insert lever arms into lock stile and hinge stile cases.
- B. Assemble axles and tighten securely. (See instructions in axle envelope.)

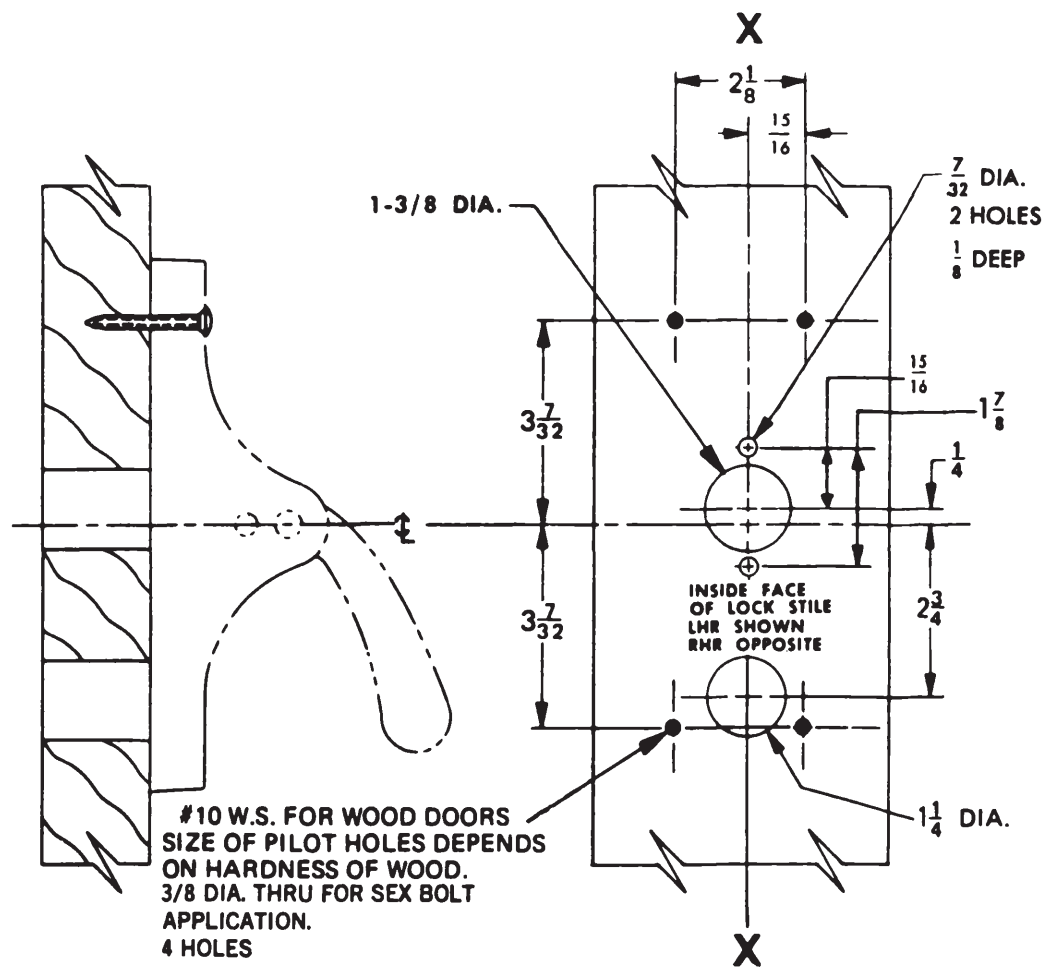
## 5. APPLY LOCK STILE CASE

- A. Remove key from cylinder.
- B. Position cylinder cam as shown in Fig. 3.
- C. Attach lock stile case to door. (See Fig. 1 or Fig. 2)
- D. Test key and thumbpiece action.

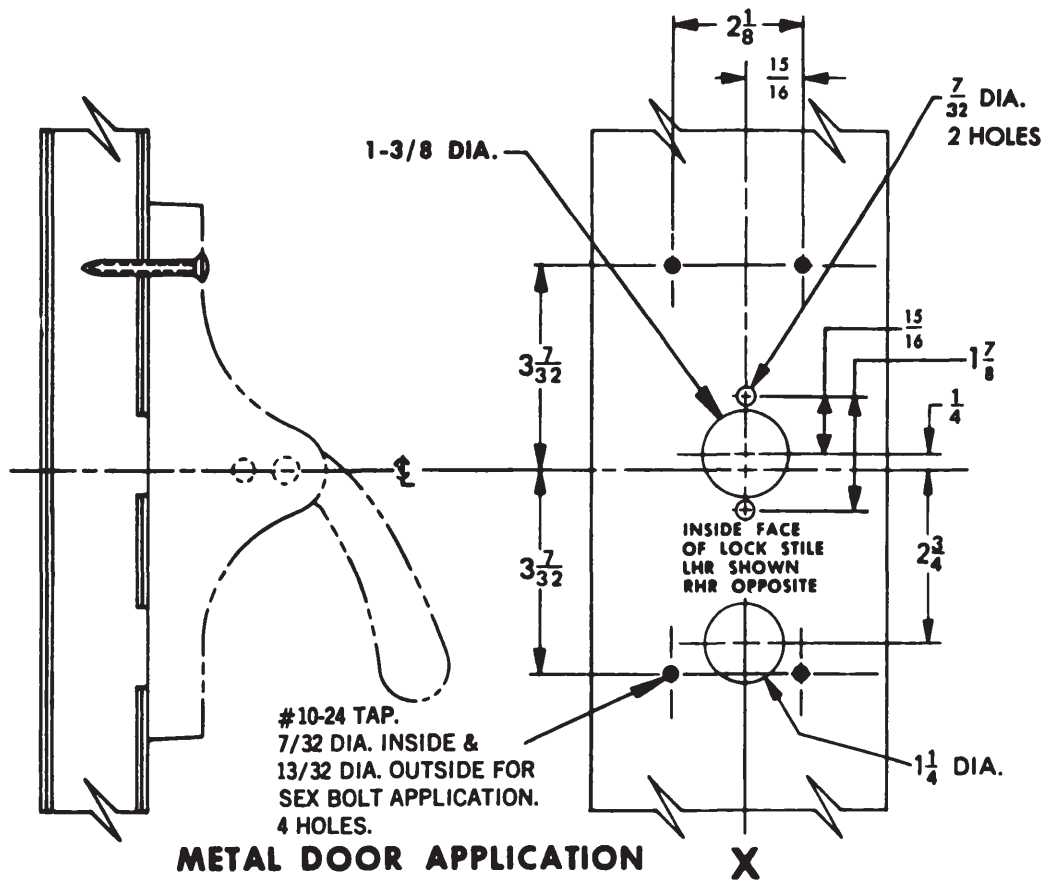
## 6. APPLY HINGE STILE CASE AND CROSSBAR TUBE (FIG. 4)

- A. Dog lever arms in depressed position.
- B. Slip crossbar tube on lock stile and hinge stile lever arms. (See Direction No. 941009 for cutting crossbar, if necessary.)
- C. Be sure crossbar is level and hinge stile case is parallel to edge of door and approximately on centerline of exposed stile.
- D. Using holes in hinge stile case, mark location and prepare door for attaching screws.
- E. Apply hinge stile case with crossbar in place.
- F. Tighten wedge-tite set screws securely with dog key and screwdriver or equivalent for leverage, and test crossbar for free action. (See Direction No. 941009 for these instructions.)

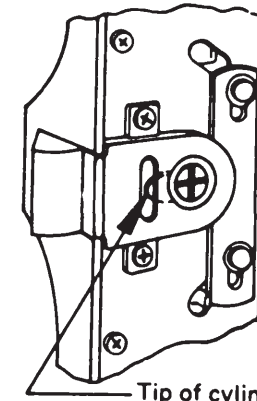
**NOTE:** When this device is ordered with two cylinder operation — inside key locks thumbpiece. When locked from inside, outside key retracts latch bolt.



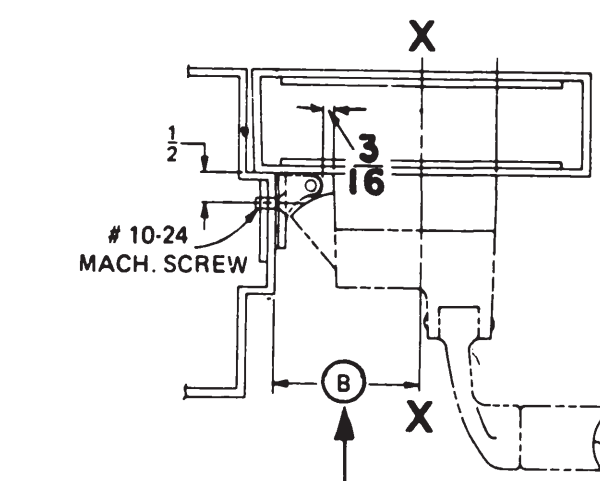
**WOOD DOOR APPLICATION**  
FIG. 1



**METAL DOOR APPLICATION**  
FIG. 2

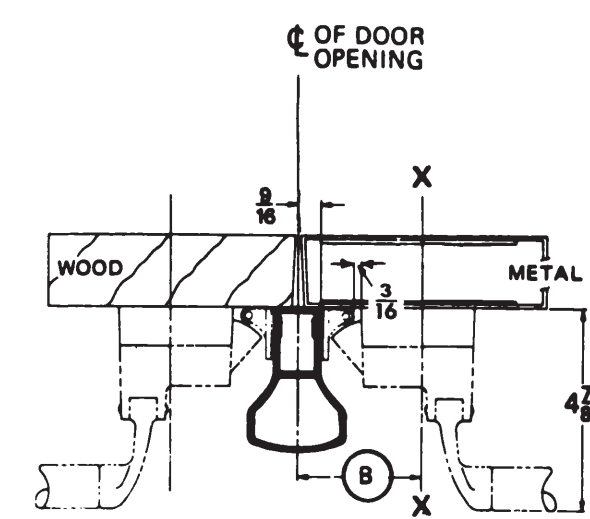


**FIG. 3**  
Tip of cylinder cam to be in this position. Be sure key is removed from cylinder.



SINGLE DOOR INSTALLATION		
STRIKE	DIMENSION (B)	MIN. STILE
299 / 299F (Shown)	2-1/2	4-3/8
264	2-1/4	4-1/8
1606	2-1/16	3-15/16

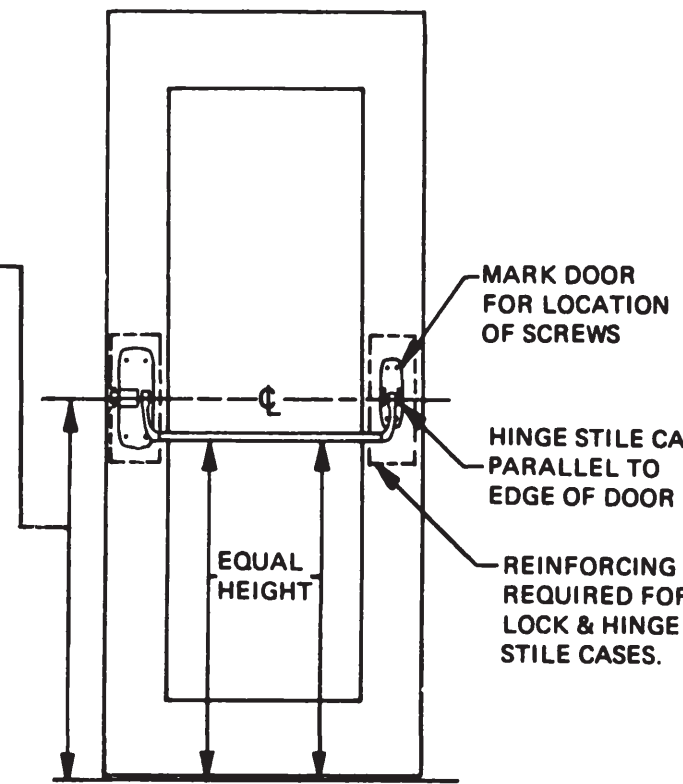
**NOTE:** FOR 1405 STRIKE SEE DIRECTION SHEET NO. 31019



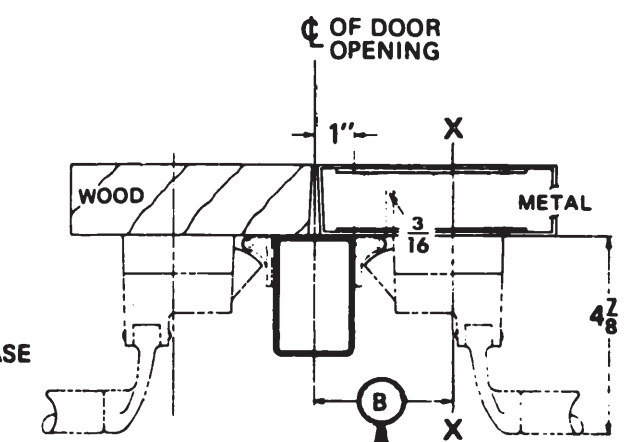
DOUBLE DOOR INSTALLATION WITH VON DUPRIN MULLIONS		
MULLION & STRIKE	DIMENSION (B)	MIN. STILE
5254 - 5654 x 299F (Shown)	3-1/16	4-1/4
5254 or 5654 x 264	2-13/16	4"

**ILLUST. 1**

SINGLE DOOR OPENING 39-13/16 TO FINISHED FLOOR	
DOUBLE DOOR OPENING WITH VON DUPRIN MULLION AND THRESHOLD	
THRESHOLD NO.	TO FIN. FLOOR
ALL THRESHOLDS	39-11/16
NO THRESHOLD (FLAT SILL)	39-11/16



**FIG. 4**



DOUBLE DOOR INSTALLATION WITH VON DUPRIN MULLIONS		
MULLION & STRIKE	DIMENSION (B)	MIN. STILE
4954 x 299 / 299F (Shown)	3-1/2	4-11/16
4654 x 264	3-1/4	4-7/16
1654 x 1606	3-1/16	4-1/4

**ILLUST. 2**



911157-00



**Customer Service**  
1-877-671-7011 www.allegion.com/us

**DESCRIPTION**

**88TP SERIES RIM DEVICES**

**DIRECTION NUMBER** 911157-00(b) **DATE** Rev. 01/14

**FOR TRIM APPLICATION SEE DIRECTIONS IN TRIM CARTON**

# VON DUPRIN

**NOTE:** FOR 1405 STRIKE SEE DIRECTION SHEET NO. 31019

