



921006-00

996L/996L-BE

VON DUPRIN®

Breakaway™ Trim for Panic and Fire
98/9975 Mortise Lock Device

Installation Instructions

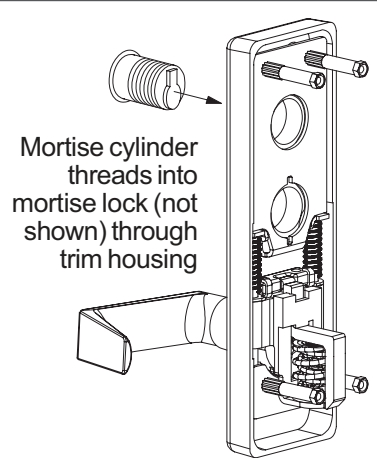
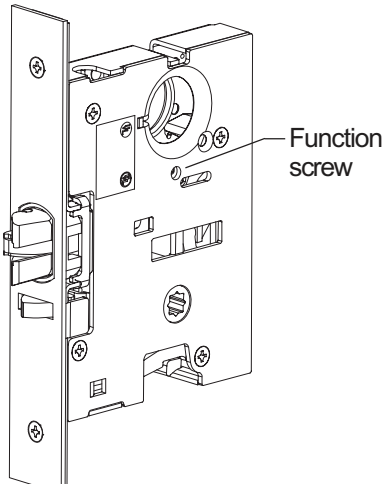
1 Prepare door for exit device.	5 Install mortise lock.
See exit device instructions for holes, backset (line X-X), and center lines.	6 Install exit device and trim.
2 Prepare door for trim:	Use 1-3/8" screws for 1-3/4" doors, 1-7/8" screws for 2" and 2-1/4" doors (cut down screws for 2" door if necessary).
2a Transfer line X-X from inside (exit device) side of door to outside (trim side) of door. Use extra care if edge of door is beveled. Be sure line X-X is parallel to edge of door.	7 For L function trim only, install mortise cylinder.
2b Locate and prepare all holes as shown.	 <p>Mortise cylinder threads into mortise lock (not shown) through trim housing</p>
3 Change handing if necessary (see other side).	
4 For L function trim only, turn mortise lock function screw all the way in.	
	

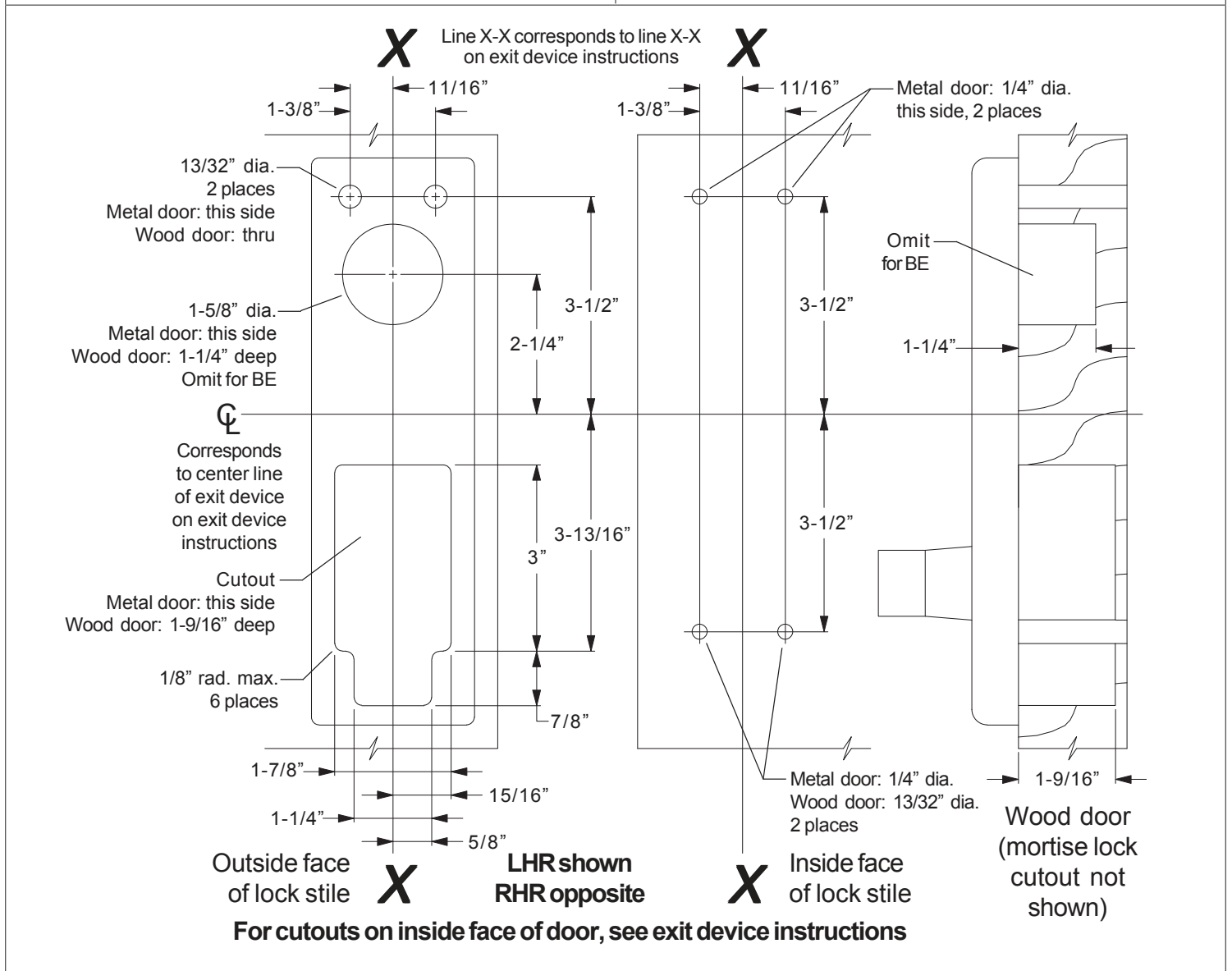

To Change Lever Handing

⚠ CAUTION ⚠

Do not remove springs from slider.

⚠ NOTE ⚠

Lever cannot be broken down unless trim is mounted on door and device is locked.

1 Remove four mounting studs.

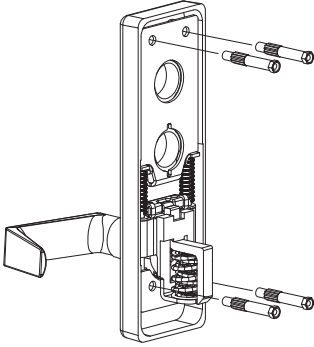

2 Remove endplate from under slider.

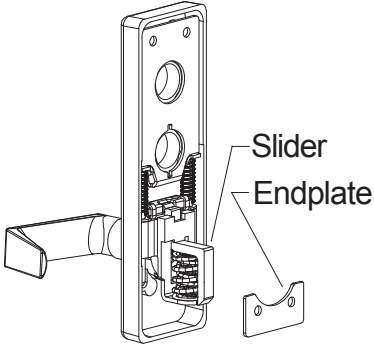

3 Push up on slider and pivot out to remove guide post assembly.

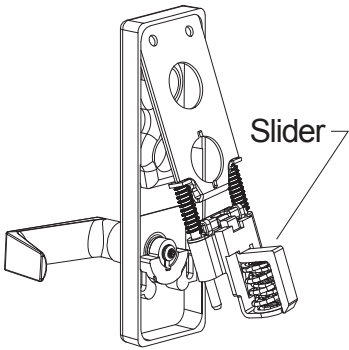

⚠ CAUTION ⚠

In Step 3, make sure to keep loose components on guide post assembly.

4 Use retaining pliers to remove retaining ring. Remove cam.

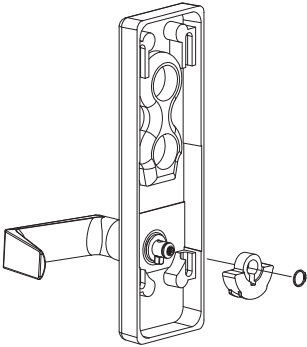

5 Use 3/32" hex wrench to loosen set screw. Remove shear pin.

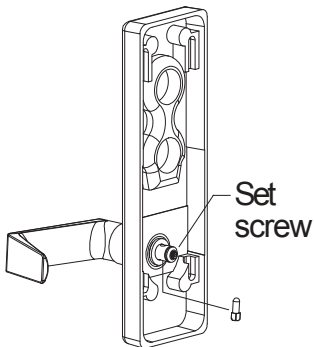

6 Remove spacer.

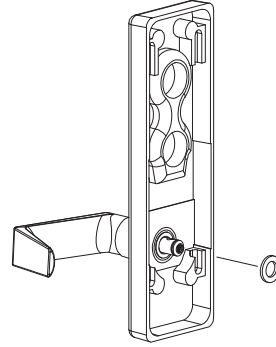

7 Place lever in RHR or LHR position.

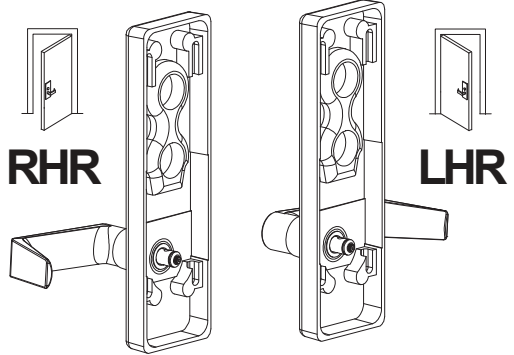

8 Re-install spacer (see Step 6).

9 Re-install shear pin with head pointed down (see Step 5).

10 Pull lever outwards to align shear pin head with spacer.

11 Re-install cam with "L" visible for LHR or "R" visible for RHR (see Step 4), then tighten set screw (see Step 5).

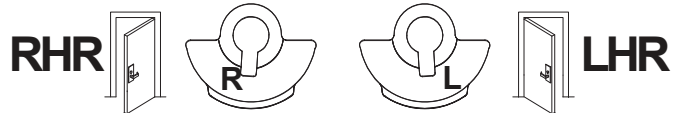

12 Re-install retaining ring (see Step 4).

13 Make sure lever is in horizontal position, then re-install guide post assembly.

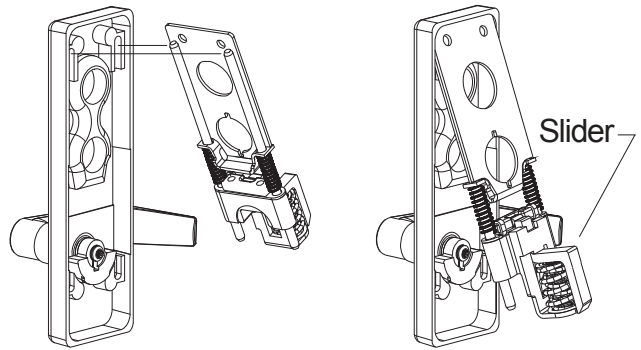

14 Re-install end plate (see Step 2) and four mounting studs (see Step 1).

ⓘ Do not over-tighten studs.

Customer Service

1-877-671-7011

www.allegion.com

