



941316-00

Chexit/RCM/DE5300

VON DUPRIN®

Service Parts Replacement

Special Instructions

Chexit/RCM/DE5300 Service Parts

Chexit Service Parts

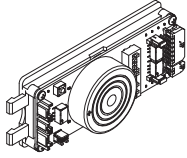

Chexit Module

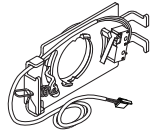

Key Switch

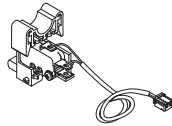

RX Switch

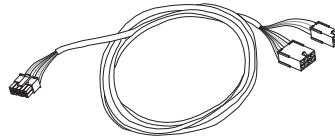

Chexit Field Wiring Cable



Blocking Device Cable (connected to motor)

DE5300/RCM Service Parts

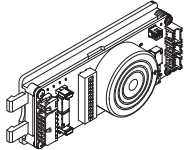

DE5300/RCM Module

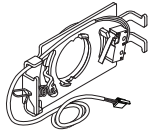

Key Switch

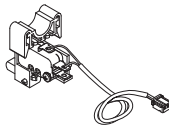

RX Switch



DE5300/RCM Field Wiring Cable



DE5300/RCM Device Wiring Cable

Table of Contents

Module Replacement on CX Device.....	2-3
Module Replacement on DE5300 or RCM Device	4-5
Key Switch Replacement CX Device.....	6
Key Switch Replacement DE5300 or RCM Device	7
RX Switch Replacement on Chexit or RCM Exit Device	8

⚠ WARNING ⚠

To avoid risk of shock, disconnect AC power from power supply before proceeding with component replacement. If using Battery Backup option, unplug all four wires from battery terminals.

Customer Service

1-877-671-7011 www.allegion.com/us



© Allegion 2015
Printed in U.S.A.
941316-00 Rev. 07/15-a

Module Replacement on a Chexit Device

1a **Removal of Chexit Module.** First, remove end cap.

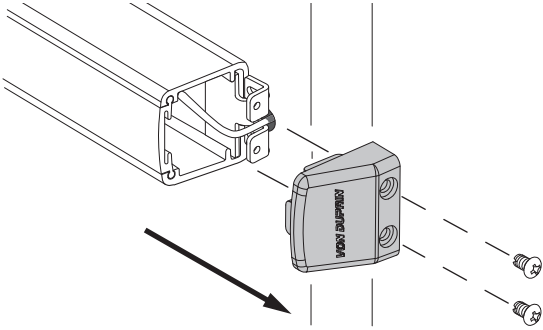

1b Slide and remove Cover Plate.

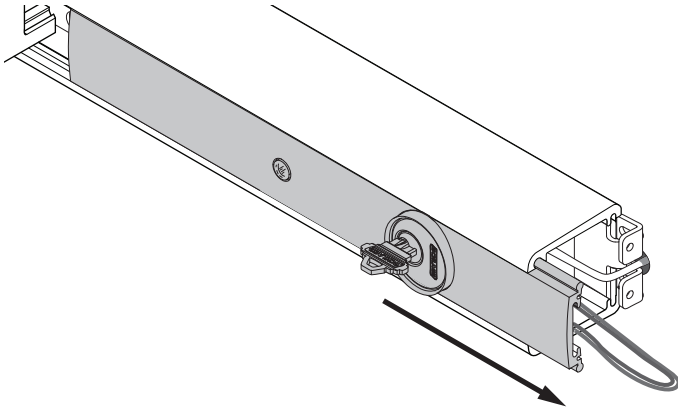

1c Remove end cap bracket.

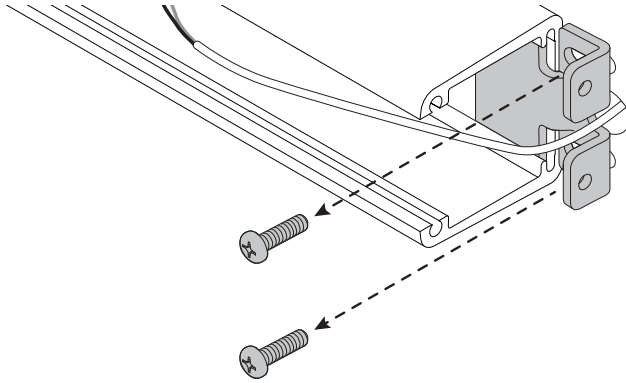

1d Slide Wire Guard out of end of case.

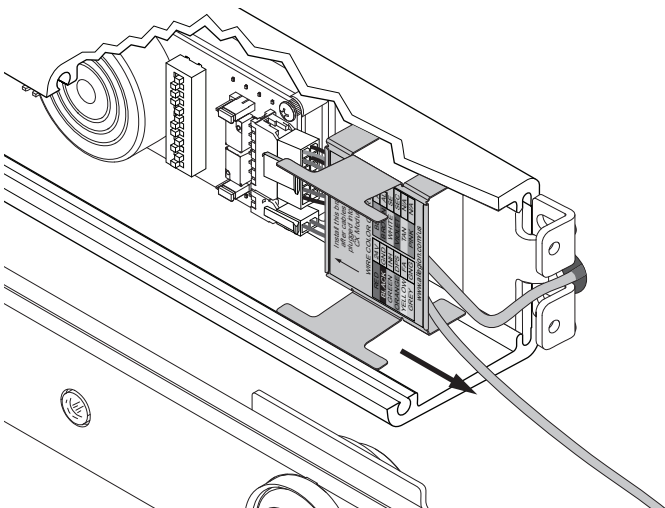

1e Press release tabs on Chexit Field Wiring Cable and Key Switch Cable to disconnect from module.

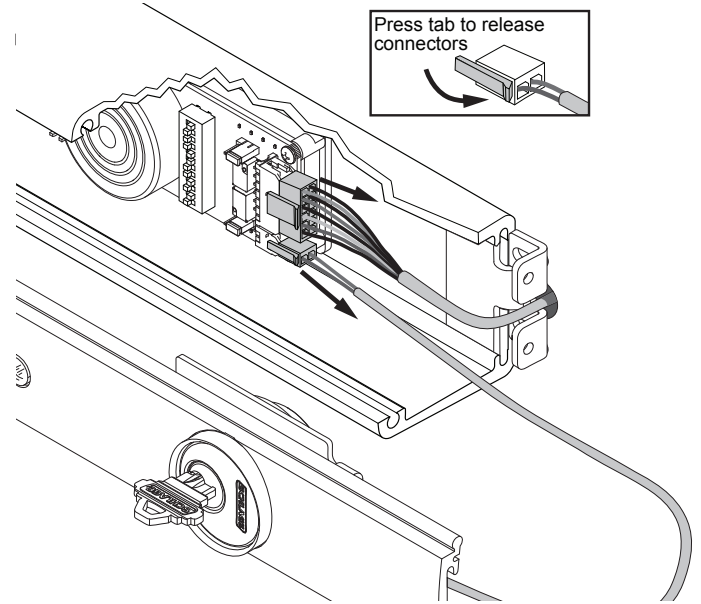

1f Insert flathead screwdriver between module and motor (only in the area shown) and pry until the module disengages.

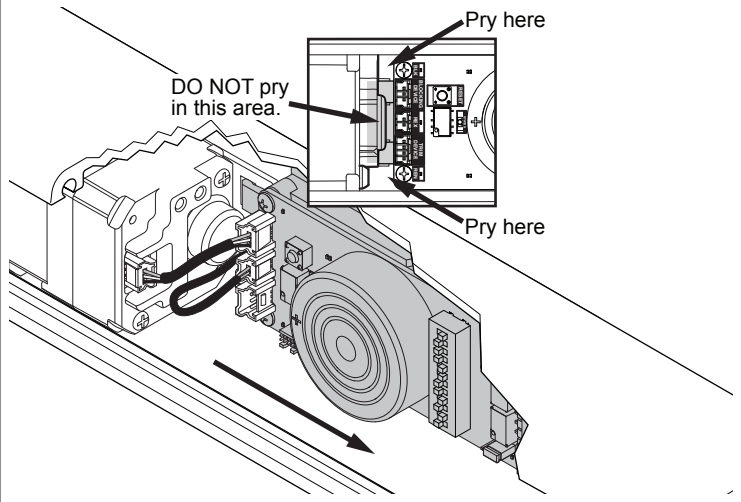

1g Disconnect Blocking Device Cable from 3-pin connector labeled "BLK" and RX Cable from 2-pin connector labeled "REX" on Module. Slide Chexit Module fully out of device case.

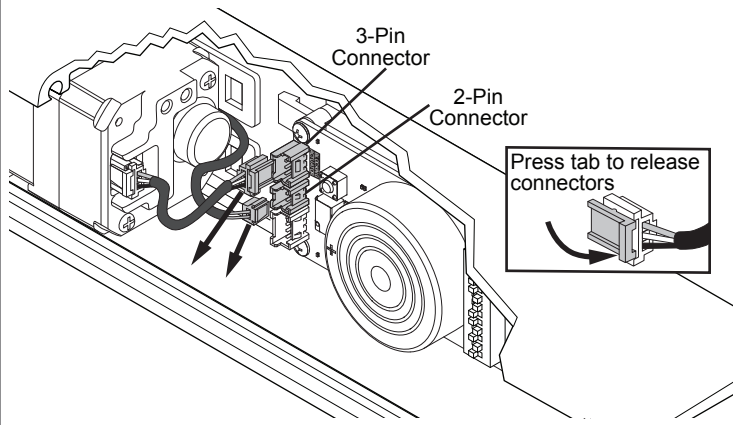

Module Replacement on a Chexit Device (Continued)

1h **Installation of Chexit Module.** First, slide Module into device case. Connect Blocking Device Cable from motor to 3-pin connector on Module. Connect 2-pin cable from under motor to Request-to-Exit connector labeled "REX" on Module.

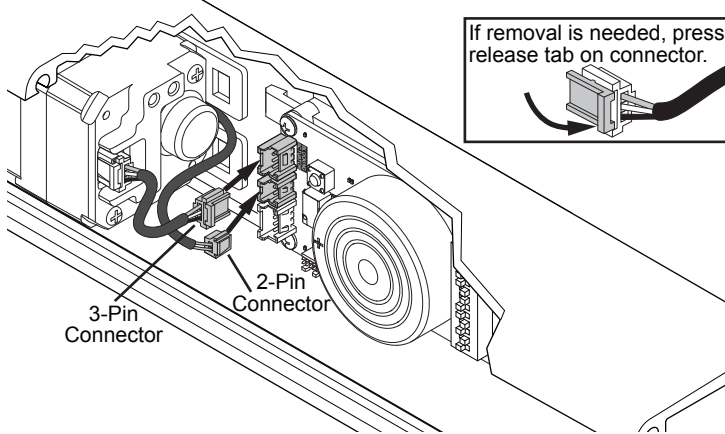

1k Slide Wire Guard into case end and above Key Switch and Chexit Door Wiring Cables until making contact with module.

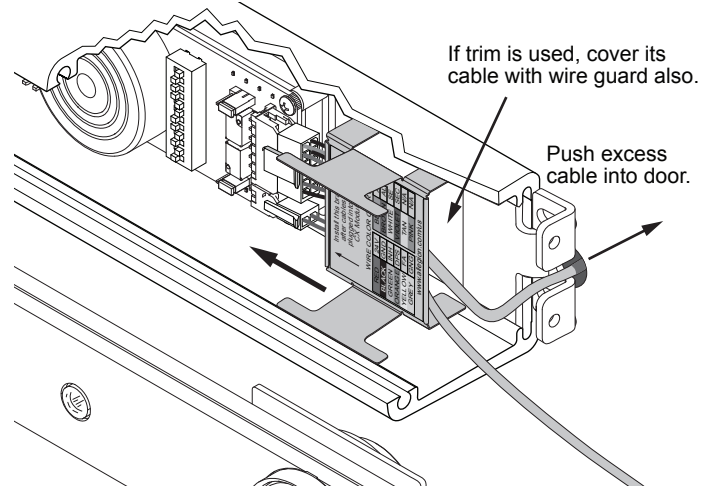

1i Push Module toward motor until it snaps into place.

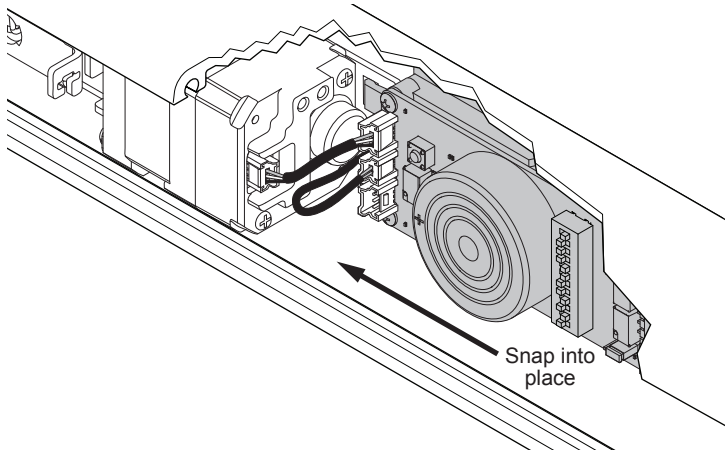

1l While keeping tension on the Key Switch Cable and pushing wires flat against door, slide Cover Plate fully into place. After Cover Plate is installed, push Key Switch Cable under the wire guard

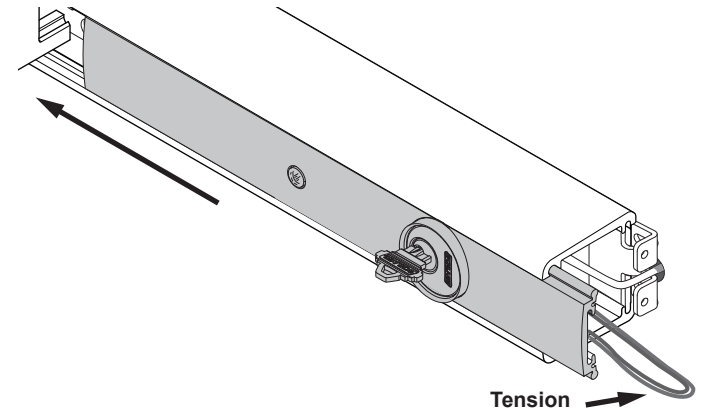

1j Connect Field Wiring Cable and Key Switch Cable to Module as shown.

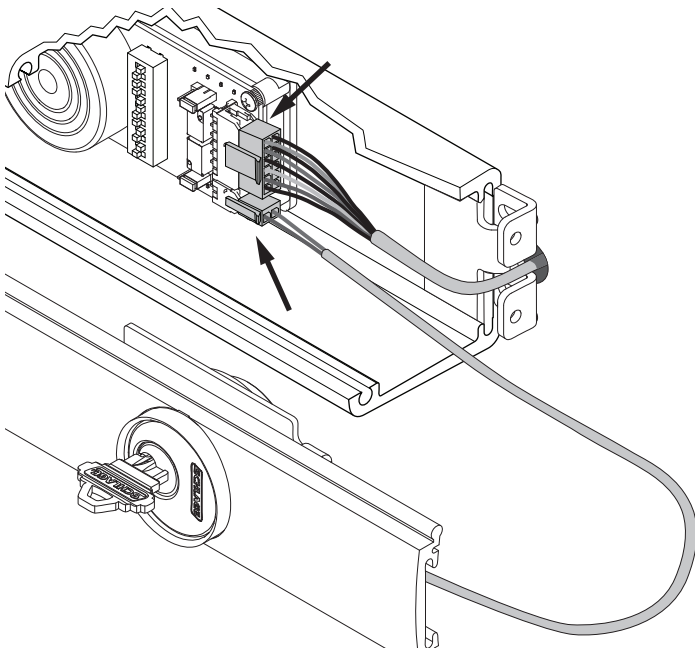

1m Install end cap.

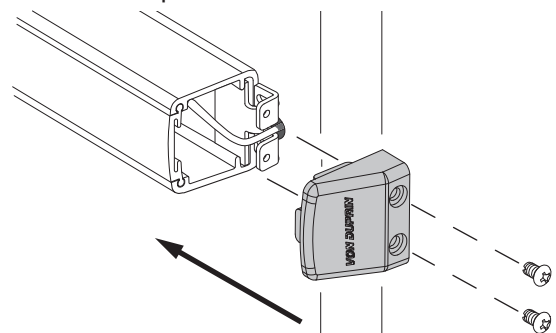

Module Replacement on DE5300 or RCM Device

1a **Removal of DE5300 or RCM Module.** First remove screws then pull out face plate and mounting bracket with Module from control box.

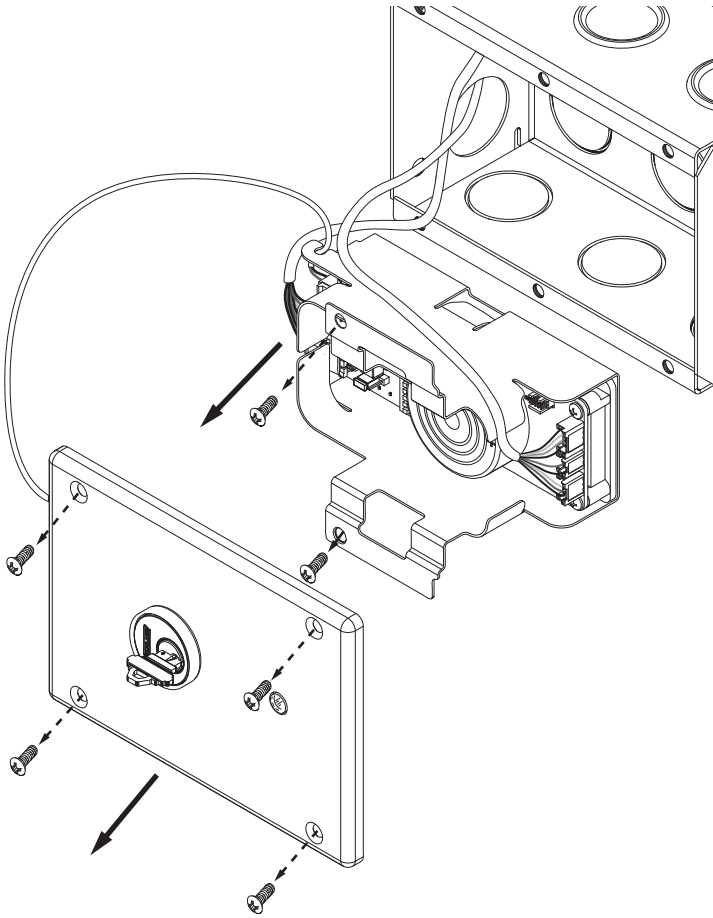

1b **Disconnect Key Switch Cable and DE5300/RCM Field Wiring Cable from Module.**

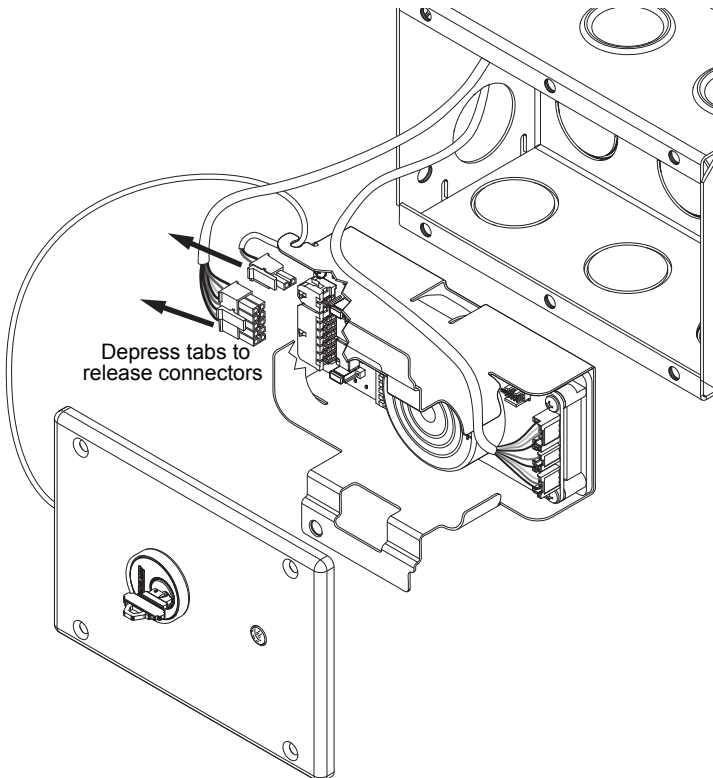

1c **Disconnect the three DE5300/RCM Device Wiring Cable connectors from the Module.**

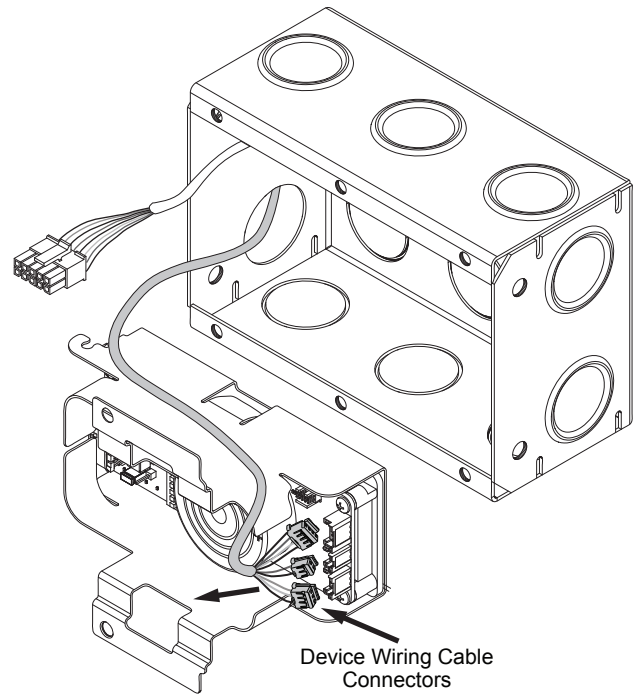

1d **Pull up on both locking tabs and slide Module out of mounting bracket.**

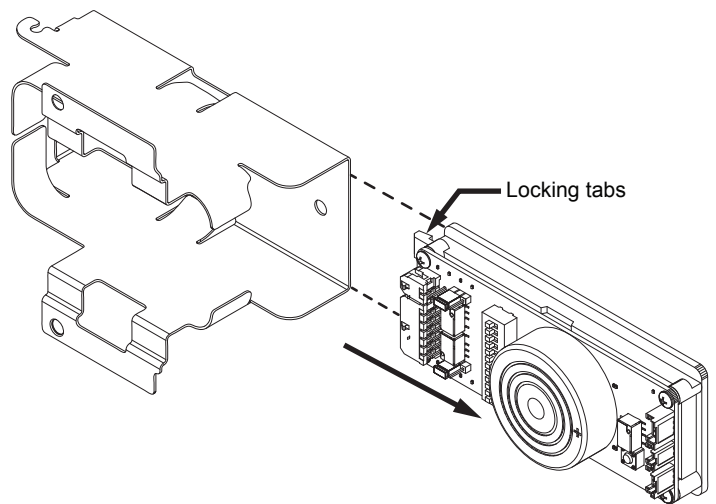

Module Replacement on DE5300 or RCM Device (Continued)

- 1e **Installation of DE5300 or RCM Module.** First slide new Module into mounting bracket until it snaps into place.

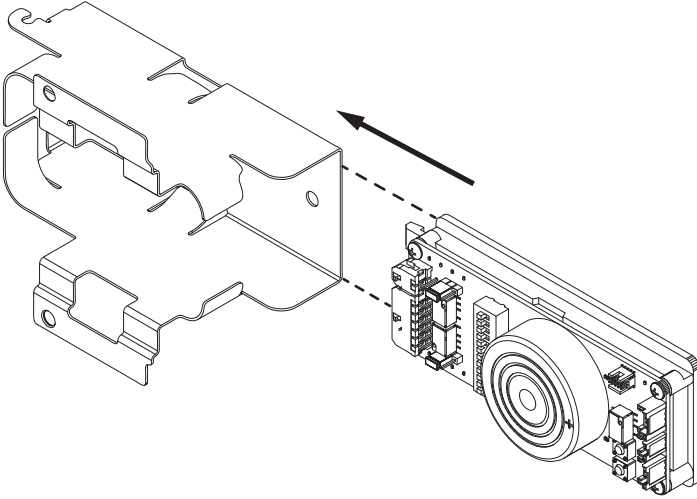

- 1f **Route DE5300/RCM Device Wiring Cable over mounting bracket and connect to Module.**

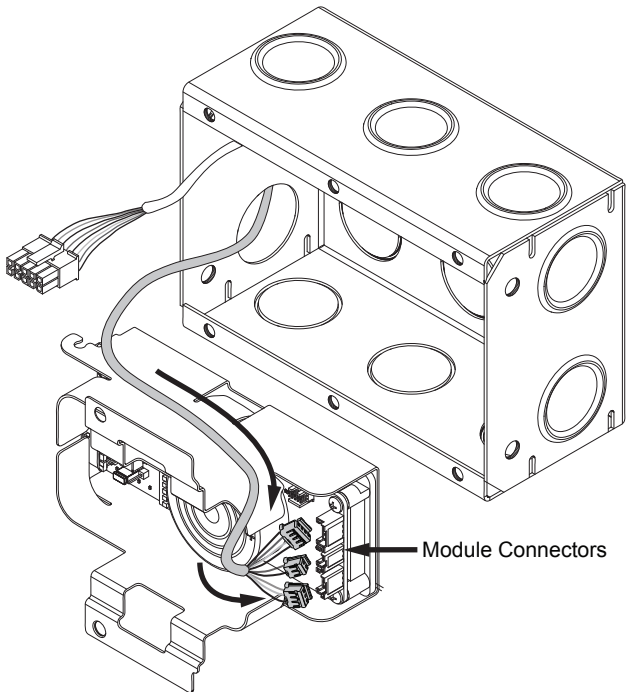

- 1g **Connect Key Switch Cable and DE5300/RCM Field Wiring Cable to Module.**

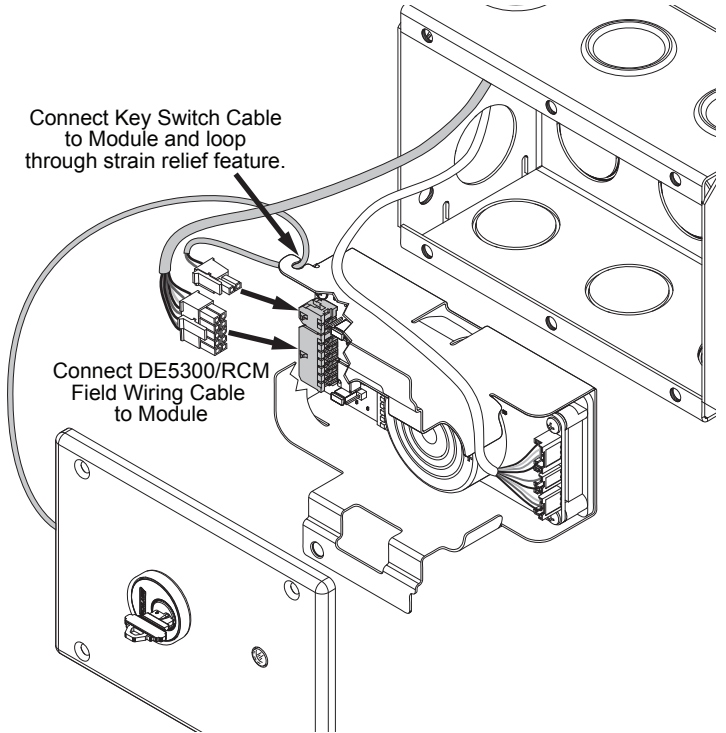

- 1h **Insert mounting bracket with Module into control box and screw into place. Screw face plate into place.**

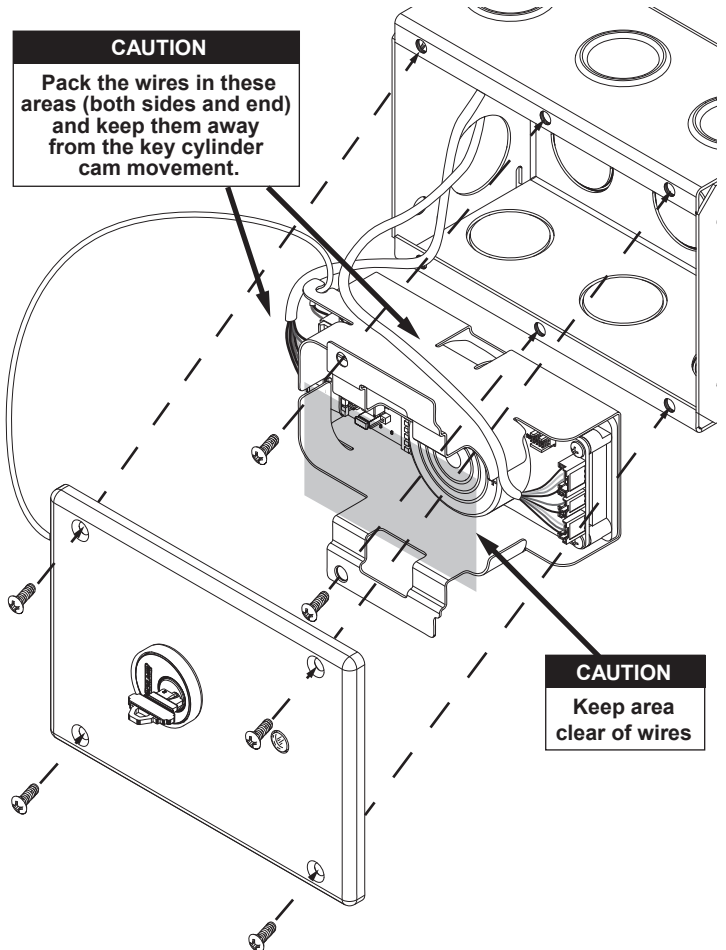

Key Switch Replacement on Chexit Device

1a Remove end cap.

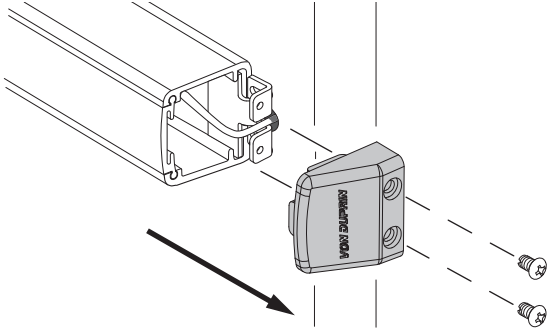

1b Slide and remove cover plate. Detach Key Switch Cable from Module.

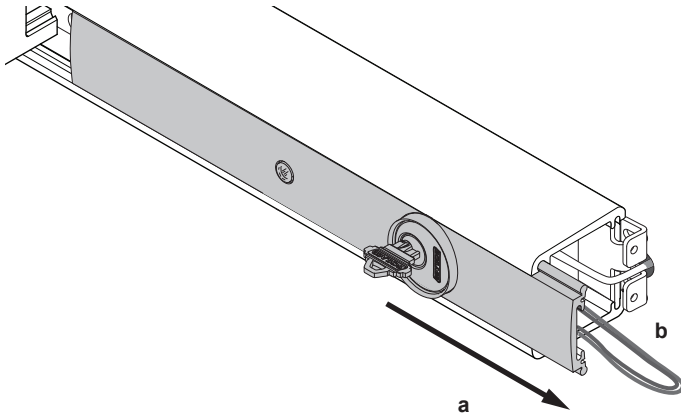

1c Disassemble cylinder.

CAUTION
Orient cylinder as shown
or unit will not operate

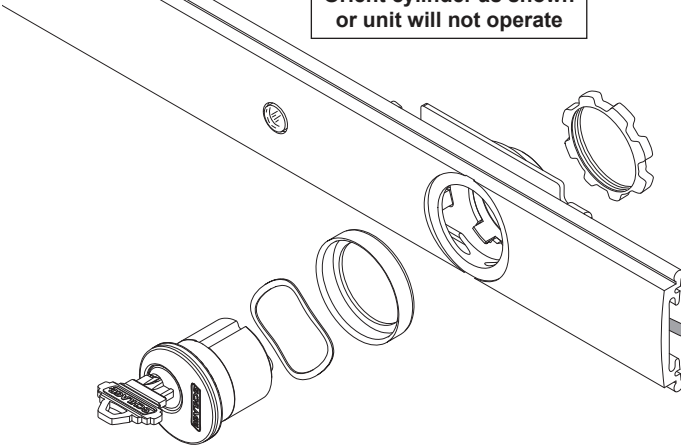

1d Slide and remove Key Switch assembly. Replace with new Key Switch assembly.

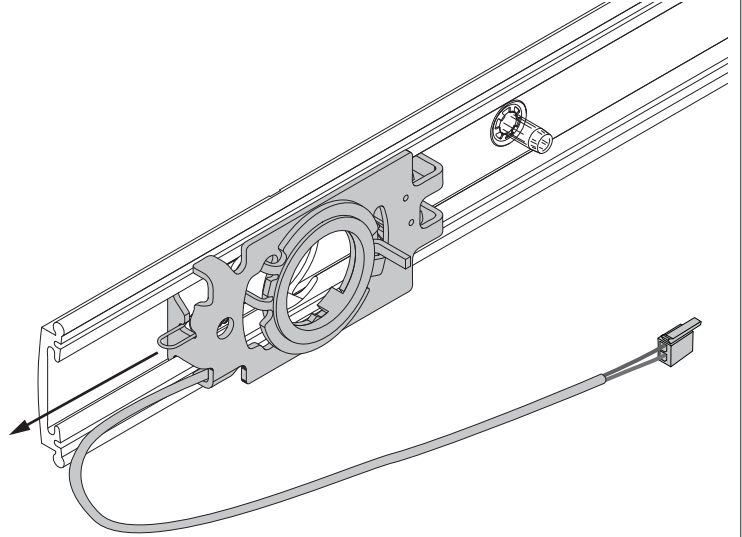

1e Reassemble cylinder per orientation shown in 1c, attach Key Switch Cable to Module, replace cover plate and end cap.

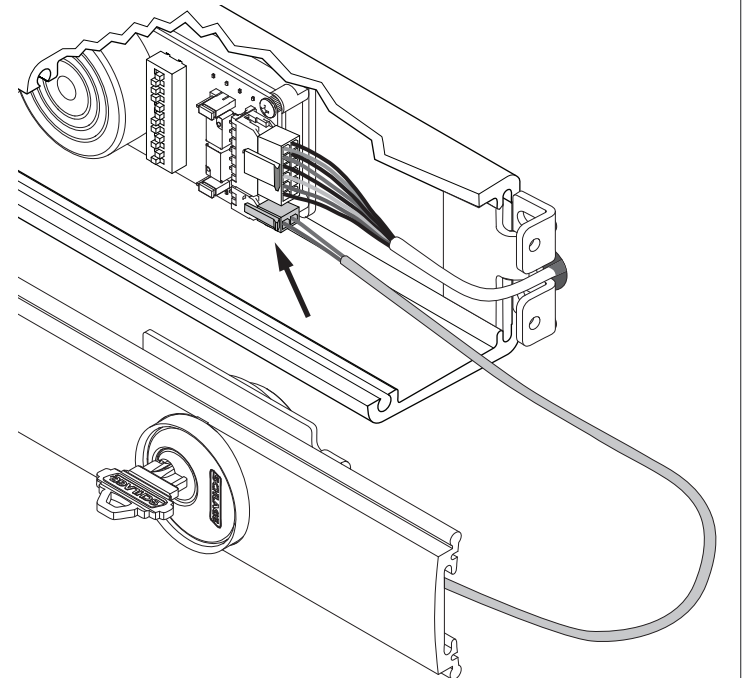

Key Switch Replacement on DE5300 or RCM Device

- 1a Remove face plate. Detach Key Switch Cable from Module.

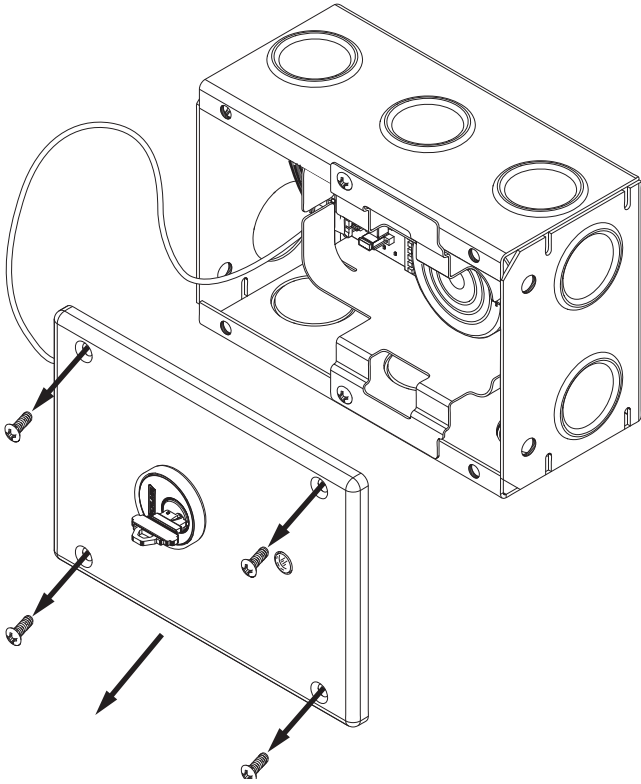

- 1c Slide and remove Key Switch assembly. Replace with new Key Switch assembly.

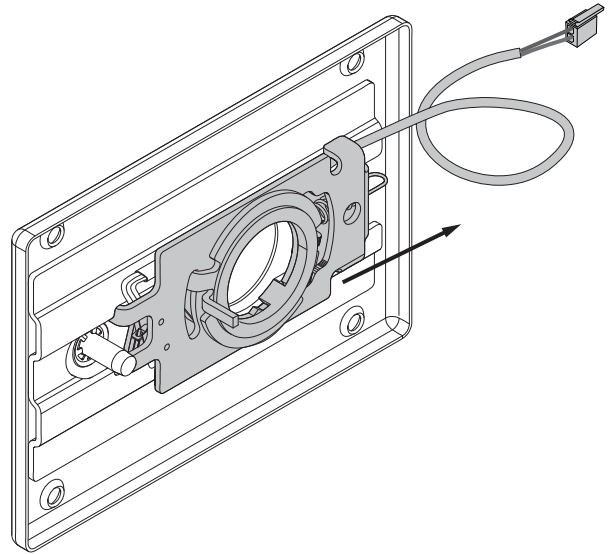

- 1b Disassemble cylinder.

CAUTION
Orient cylinder as
shown or unit will
not operate

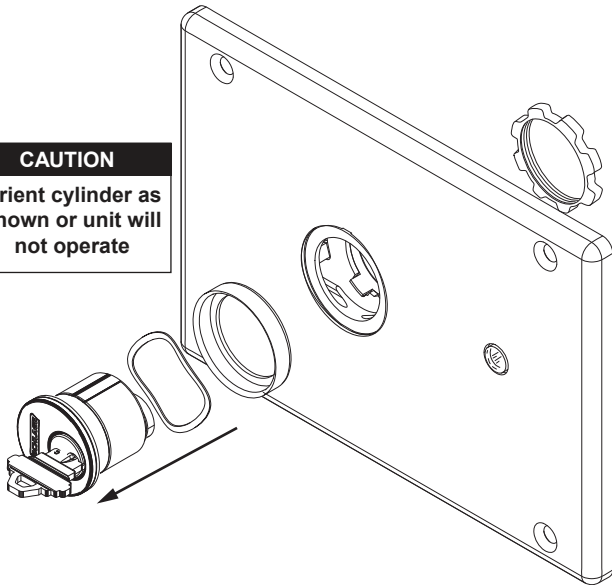

- 1d Reassemble cylinder per orientation shown in 1b, attach Key Switch Cable to Module and replace face plate.

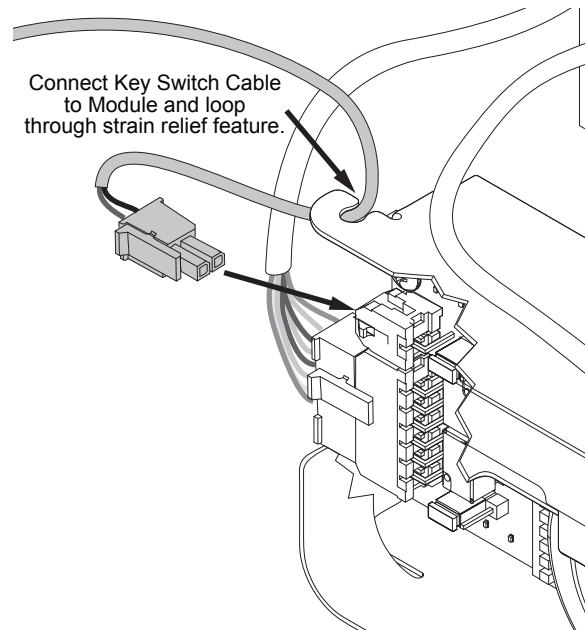

RX Switch Replacement on Chexit or RCM Device

1a Remove centercase cover, end cap, cover plate, and end cap bracket.

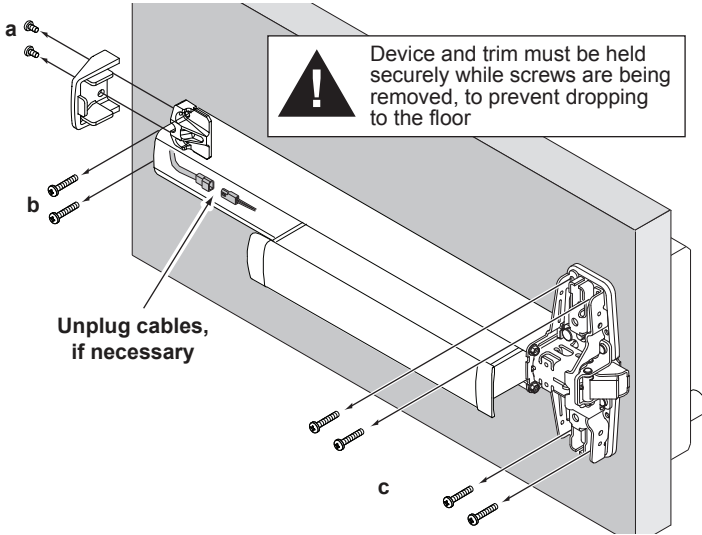

1b Remove centercase screws and slide case off of baseplate. Lift off push pad.

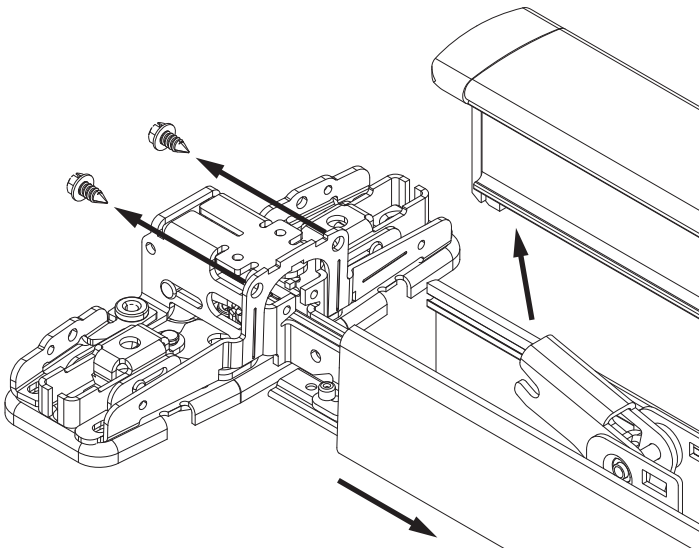

1c Remove old RX switch.

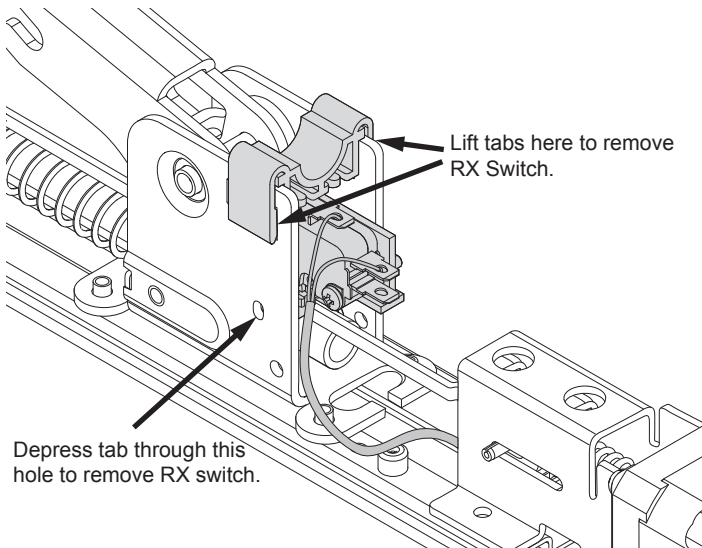

1d Install new RX switch.

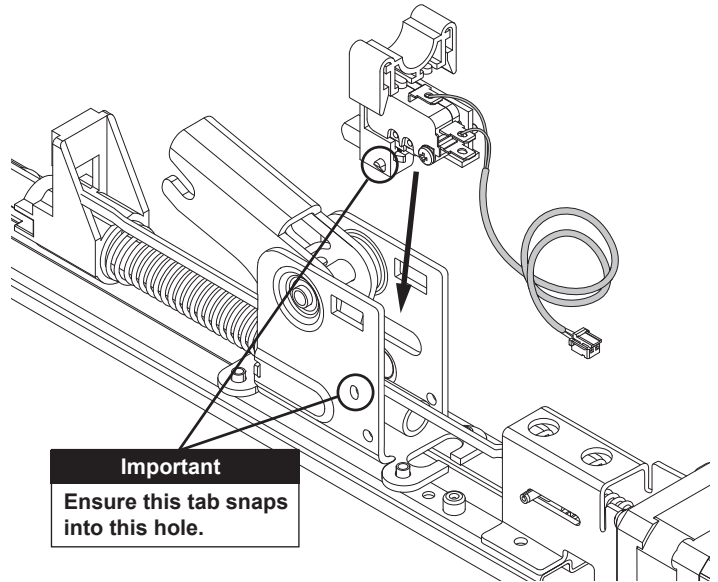

1e Route RX Cable through the bracket slot and under the motor assembly as shown. Secure cable with wire tie supplied.

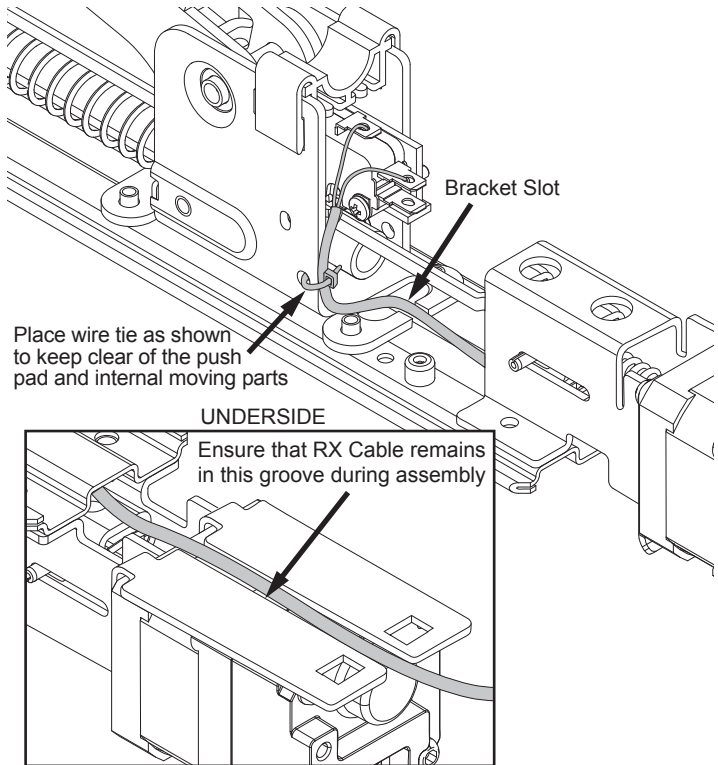

1f Reinstall push pad, case and centercase screws. Mount exit device on door. Reinstall end cap bracket, cover plate, end cap and centercase cover.

1g **IMPORTANT:** Test proper function of device. Refer to the Basic Functional Test in the Chexit or RCM instructions to confirm the push pad on the Chexit / RCM exit device is working properly.