



640057-00

LM/DM

FALCON®

Installation Instructions
Instrucciones de Instalación
Notice d'installation

1 If replacing switch, see other side of this sheet.
If replacing switch, see other side of this sheet.
If replacing switch, see other side of this sheet.

2 Review Function of Switch
Revisar la función del interruptor
Réviser la fonction de l'interrupteur

LM

Indicates when latch is fully retracted
Indica que el pestillo está completamente replegado
Indique lorsque le verrou est complètement rétracté

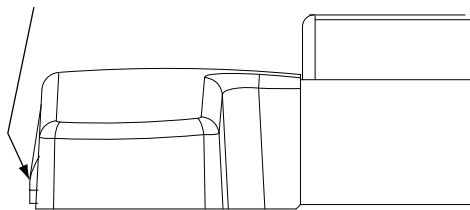

Latch fully retracted
El pestillo está completamente replegado
Le verrou est complètement rétracté

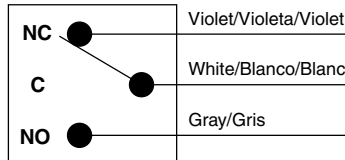

Latch not fully retracted
El pestillo no está completamente replegado
Le verrou n'est pas complètement rétracté

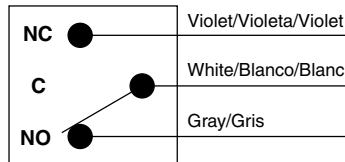

OR
O
OU

DM

Indicates when latch is fully extended
Indica que el pestillo está completamente extendido
Indique lorsque le verrou est complètement sorti

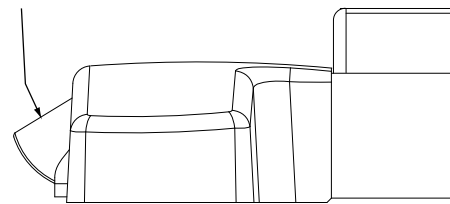

Latch fully extended
El pestillo está completamente extendido
Le verrou est complètement sorti

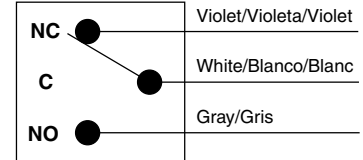

Latch not fully extended
El pestillo no está completamente extendido
Le verrou n'est pas complètement sorti

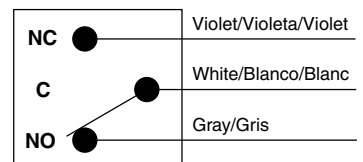

3 Drill Wire Access Hole
Perfore el orificio de acceso del cable
Orifice d'accès pour câble

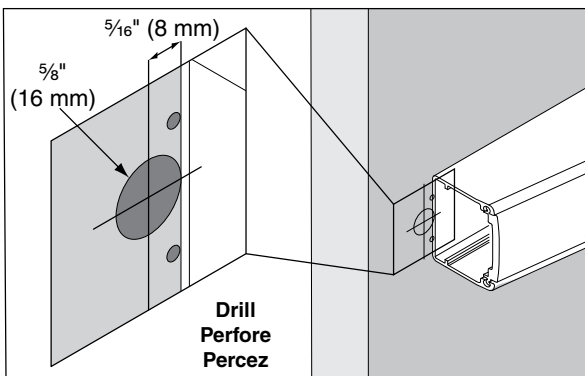

4 Route wires through frame using Electric Hinge or Power Transfer
Enrute los cables a través del marco utilizando la bisagra eléctrica o transferencia de energía
Acheminez les câbles par la structure en utilisant une charnière électrique ou une transmission de puissance

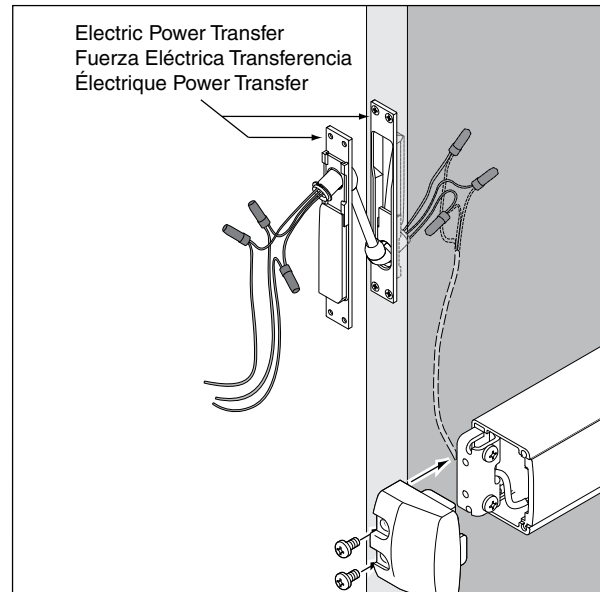

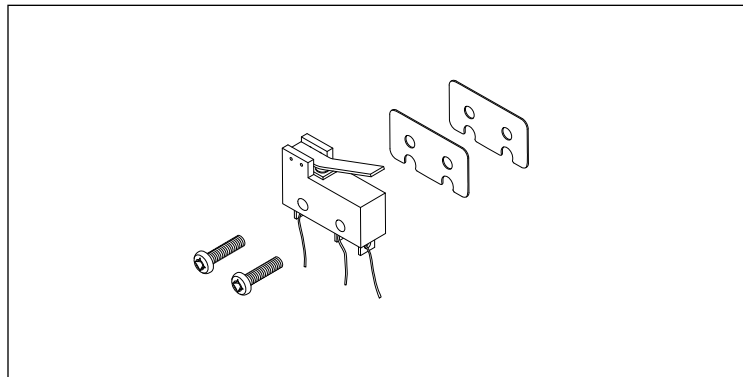

1 Remove Cover
 Retire la cubierta
 Retirez le couvercle

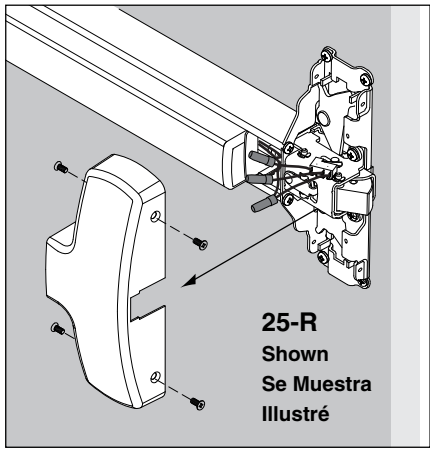

2 Remove 3 Wire Nuts
 Retire 3 empalmes plásticos
 Enlevez les trois capuchons de connexion

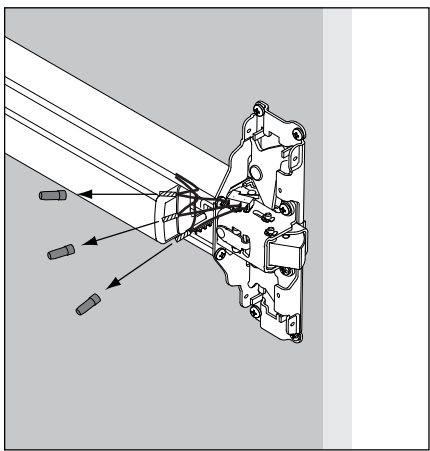

3 Replace Switch
 Cambie el interruptor
 Remplacer l'interrupteur

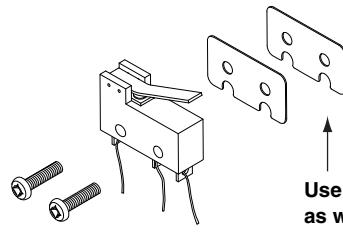

Use same number of insulators
 as were installed at factory.
 Utilice la misma cantidad de
 aisladores instalados en la fábrica.
 Utilisez le même nombre d'isolateurs
 que lors de l'installation en usine.

4 Install Wire Nuts
 Instale los empalmes plásticos
 Installez les capuchons de connexion

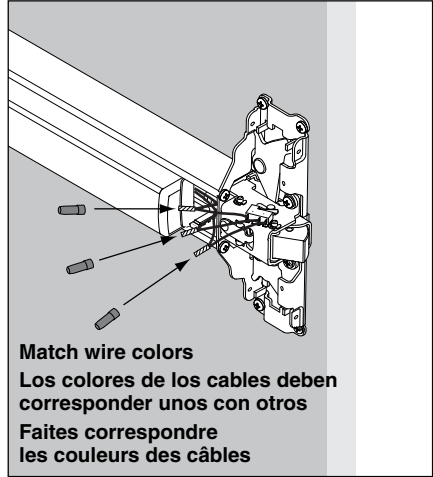

5

