

Installation Instructions

Wall Strike Applications bottom of door

NOTES: Reinforcing of metal doors recommended. Use sex bolts on metal doors not reinforced. Recommended mounting is stop on door. Remove and discard safety set screw except for inverted, top of door applications.

- 1: Mount back plate with centerline $3\frac{1}{2}$ " from latch edge of door and top of plate 5" from bottom of door, as indicated in illustrations at right and below. Locate screw holes by using back plate as template. Use #8 x 1" flat head sheet metal screws for wood doors, or #8-32 x $\frac{1}{2}$ " flat head machine screws for reinforced metal doors.
- 2: Place stop assembly on back plate and push it down on tapered legs, with locking set screw fully retracted. Then raise stop assembly approx. $\frac{1}{4}$ " (to provide adjustment) and lock in position with locking set screw.
- 3: Hold strike under stop assembly with roller fully engaged in slot. Move door so as to contact wall with strike. Locate strike screw holes, using strike as template.
- 4: Mount strike with four #12 x $1\frac{1}{4}$ " oval head screws.
- 5: Adjust stop assembly on back plate to $\frac{3}{16}$ " clearance between housing and strike as shown in illustration, using a $\frac{3}{16}$ " drill as spacer. Secure with locking set screw.
- 6: Holding power is adjusted by turning adjusting screw counter-clockwise to increase tension and clockwise to decrease tension. Further adjustment can be made by moving stop assembly up or down on back plate.

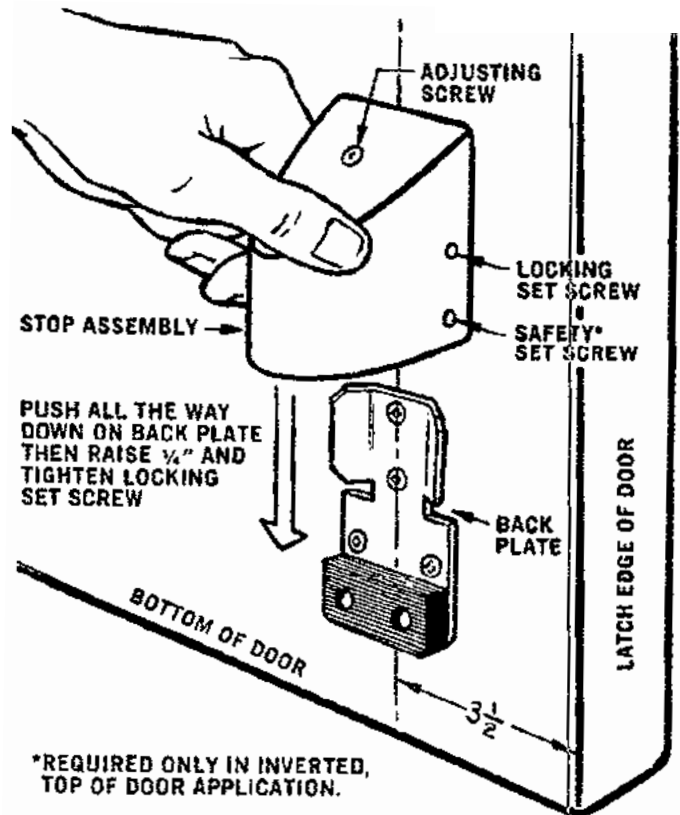

*REQUIRED ONLY IN INVERTED, TOP OF DOOR APPLICATION.

WALL STRIKE APPLICATIONS top of door

- 1: Mount back plate with centerline $3\frac{1}{2}$ " from latch edge of door and top of plate $1\frac{1}{4}$ " from top of door, as indicated in illustration at left. Locate screw holes by using back plate as template. Use #8 x 1" flat head sheet metal screws for wood doors, or #8-32 x $\frac{1}{2}$ " flat head machine screws for reinforced metal doors.
- 2: Follow instructions 2 through 6 as outlined above for No. 495 bottom of door application.

top of door (inverted)

- 1: Mount backplate (inverted, with rubber bumper at top) with centerline $3\frac{1}{2}$ " from latch edge of door and top of plate (inverted, see illustration) 5" from top of door. Locate screw holes, etc. as in instruction 1 above.
- 2: Place stop assembly on back plate and push it up on tapered legs, with locking set screw fully retracted. Then lower stop assembly approx. $\frac{1}{4}$ " (to provide adjustment) and lock in position with locking set screw. Secure safety set screw by turning until head is flush with housing. Screw then extends beyond dovetail of backplate and prevents stop assembly from falling when final adjustment is being made.
- 3: Hold strike in inverted position over stop assembly with roller fully engaged in slot. Follow instructions 3, 4, 5 & 6 at top of page.

USE OF ARCUATE SLOT

CURVED SLOT IN STRIKE PERMITS USE OF WALL STRIKE WHEN DOOR AND WALL ARE NOT PARALLEL.

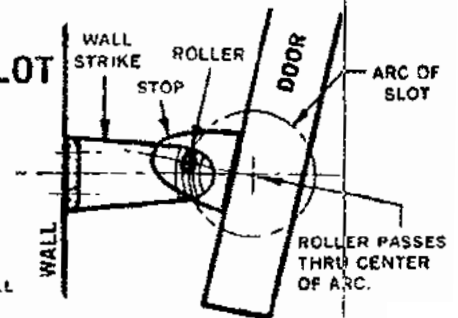

BOTTOM OF DOOR

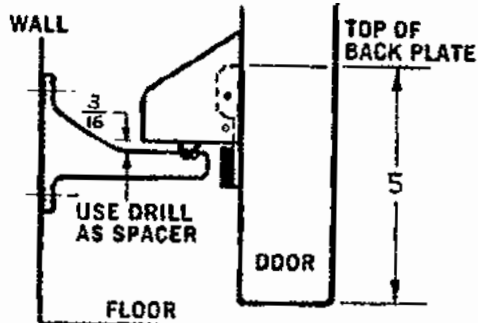

TOP OF DOOR

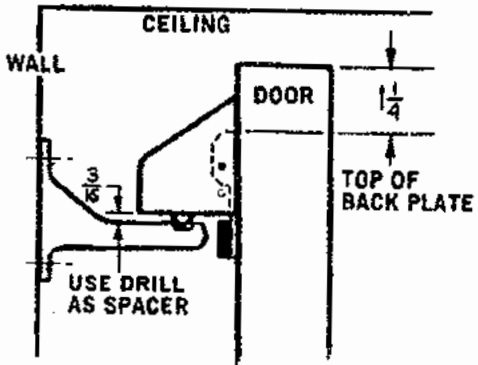

TOP OF DOOR (INVERTED)

