

SINGLE DOOR INSTALLATION			
DEVICE	DIM "B"	DIM "C"	MIN STILE
33/35 RIM	19/32"	1 7/16"	1 3/4"
44 RIM EO,DT,NL,TP	1 11/16"	1 7/16"	3 3/8"
44 RIM K	1 9/16"	1 7/16"	3 3/8"
55 RIM	17/32"	1 7/16"	1 3/4"
22 RIM	1 9/16"	1 9/16"	3 13/16"
88 RIM EO,DT,NL,TP	1 11/16"	1 7/16"	3 3/8"
88 RIM K,L	1 9/16"	1 7/16"	3 3/8"
98/99 RIM	1 9/16"	1 9/16"	3 13/16"
75 RIM	19/32"	1-7/16"	1-3/4"
78 RIM	1-9/16"	1-9/16"	3-13/16"

LINE X-X CORRESPONDS TO LINE X-X ON DEVICE TEMPLATE

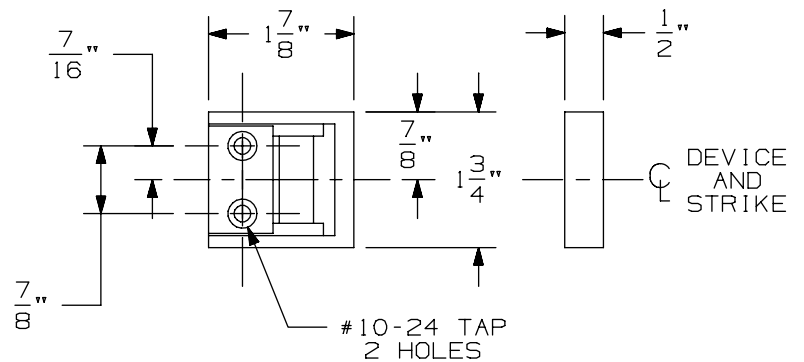
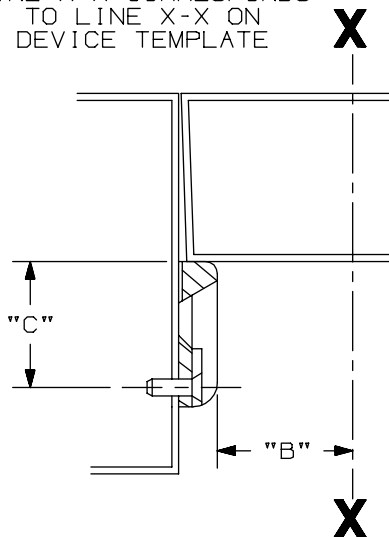

LHR APPLICATION SHOWN, RHR APPLICATION OPPOSITE

1409 Strike

VON DUPRIN®

NOTES: SEE MASTER SHEET #10001 FOR SUGGESTED REINFORCING

TEMPLATE NUMBER:

30022_b

DATE:
04-12-24