

SINGLE DOOR INSTALLATION			
DEVICE	DIM "B"	DIM "C"	RECOMMENDED MIN STILE*
33A/35A RIM	19/32"	1 9/16"	2"
44 RIM EO,DT,NL,TP	1 11/16"	1 9/16"	3 3/8"
44 RIM K	1 9/16"	1 9/16"	3 3/8"
55 RIM	17/32"	1 9/16"	1 3/4"
22 RIM	1 9/16"	1 9/16"	3 13/16"
88 RIM EO,DT,NL,TP	1 11/16"	1 9/16"	3 3/8"
44 RIM K,L	1 9/16"	1 9/16"	3 3/8"
98/99 RIM	1 9/16"	1 9/16"	3 13/16"
75 RIM	19/32"	1-9/16"	2"
78 RIM	1-9/16"	1-9/16"	3-13/16"

①

LINE X-X CORRESPONDS TO LINE X-X ON DEVICE TEMPLATE

X

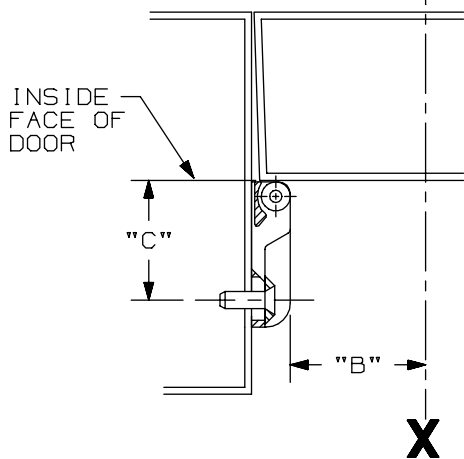

\* CONSULT FACTORY FOR STILE WIDTHS LESS THAN MIN. RECOMMENDED TO ENSURE PROPER APPLICATION

①

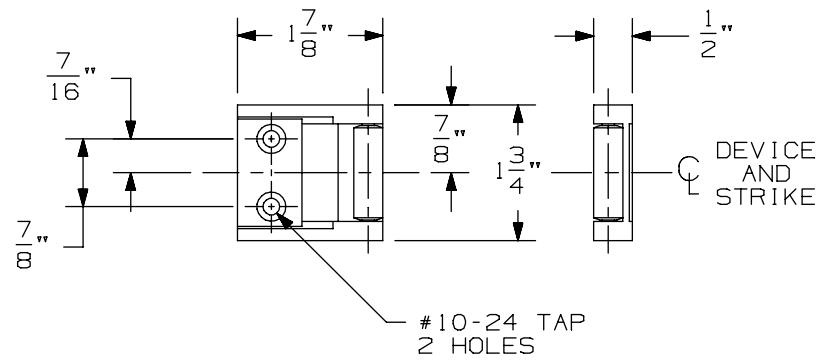

LHR APPLICATION SHOWN, RHR APPLICATION OPPOSITE

1439 Roller Strike

**VON DUPRIN**

NOTES: SEE MASTER SHEET #10001 FOR SUGGESTED REINFORCING

TEMPLATE NUMBER:

30029\_b

DATE:  
04-10-24