

**INSTALLATION DIRECTIONS**

**BEFORE APPLYING THIS DEVICE**

- A. Threshold (if any) must be installed.
- B. Doors must be fitted and hung.
- C. Check that handing of hardware corresponds with handing of door. (See form 74 for changing the device handing if required.)

**1. APPLY STRIKE**

- A. Tape appropriate strike template to stop.
- B. When Von Duprin Mullion is used apply strike at tapped holes in Mullion. (See illustration 1, 2, or 3.)
- C. For single door application. (See illustration 4, 5 or 6)

**2. PREPARE DOOR**

- A. Tape full size template No. 1 or 2, depending on handing of door, to inside face of lock stile. See device height schedule.

**N** BE SURE CENTERLINE OF LOCK STILE CASE IS PARALLEL TO STOP AND THAT EDGE OF CASE IS 3/16 FROM EDGE OF STRIKE. STRIKE MUST BE SHIMMED OUT IF LOCK CASE IS MOUNTED MORE THAN 3/16 FROM STRIKE.

- B. Prepare door as shown. See Fig. 1 for wood door application, and Fig. 2 for metal door application.

**3. APPLY OUTSIDE TRIM**

- A. See directions in trim carton. Line "X-X" on trim template corresponds to line "X-X" on device template and is parallel to edge of door. Transfer line "X-X" from inside face to outside face of door.
- B. Prepare outside face of lock stile.
- C. Cut off cylinder tailpiece, if necessary, to extend 5/16 to 7/16 thru door and into device case.
- D. Install cylinder assembly.
- E. Apply outside trim.

**4. APPLY LOCK STILE CASE**

- A. Remove key from cylinder.
- B. Attach lock stile case to door. (See Fig. 1 or Fig. 2)
- C. Test key action.

**5. APPLY HINGE STILE CASE AND CROSSBAR TUBE (FIG. 4)**

- A. Dog lever arms in depressed position.
- B. Slip crossbar tube on lock stile and hinge stile lever arms. (See Direction No. 941009 for cutting crossbar, if necessary.)
- C. Be sure crossbar is level and hinge stile case is parallel to edge of door and approximately on centerline of exposed stile.
- D. Using holes in hinge stile case, mark location and prepare door for sex bolts.
- E. Apply hinge stile case with crossbar in place.
- F. Tighten wedge-lite set screws securely with dog key and screwdriver or equivalent for leverage and test crossbar for free action. (See Direction No. 941009 for these instructions.)

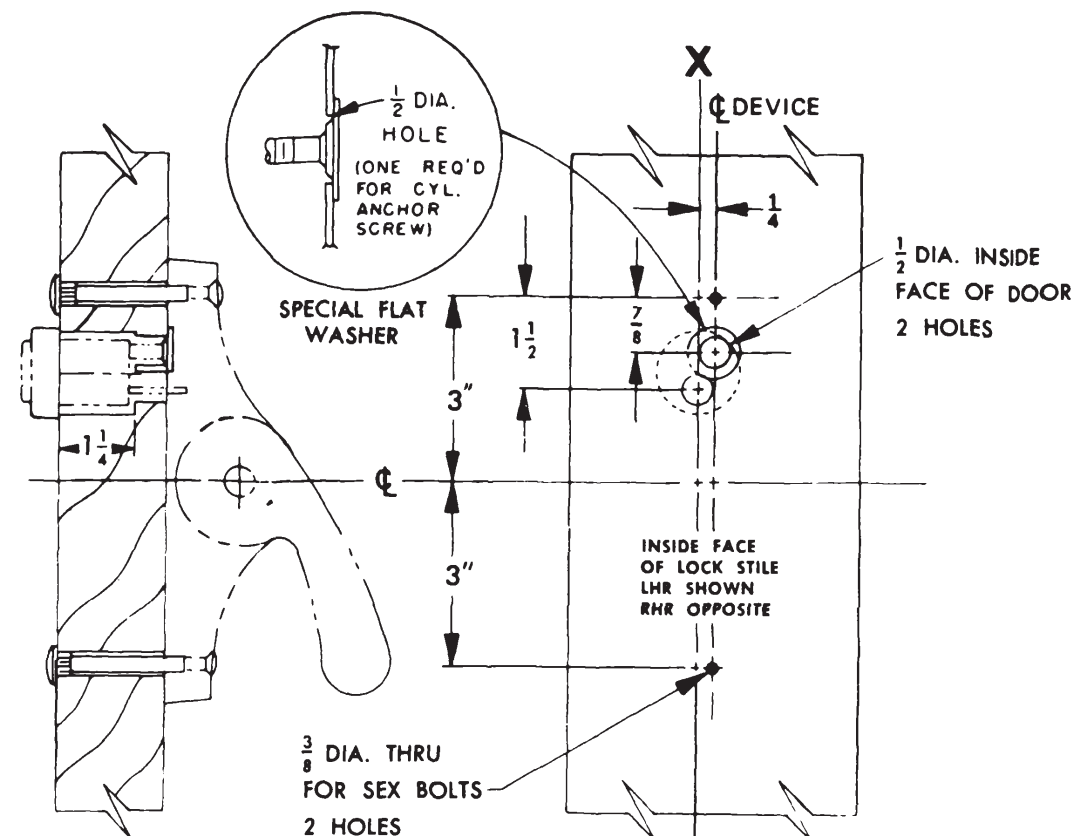

**WOOD DOOR APPLICATION FIG. 1**

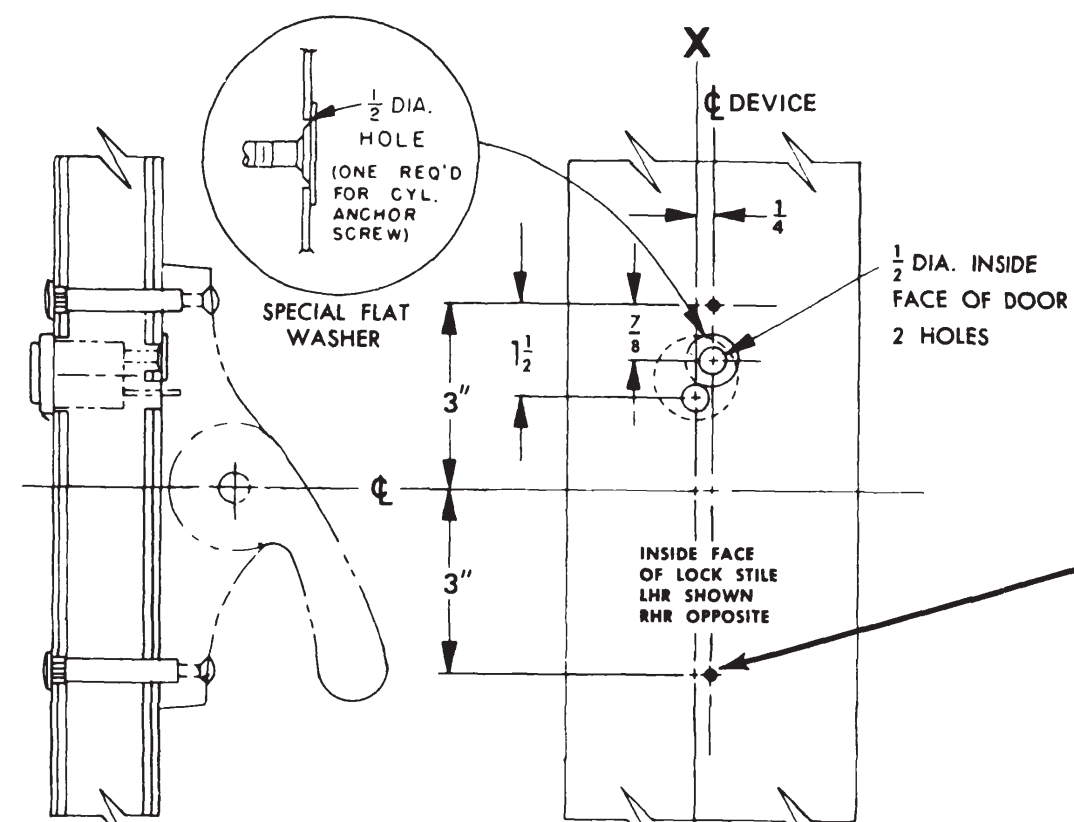

**METAL DOOR APPLICATION FIG. 2**

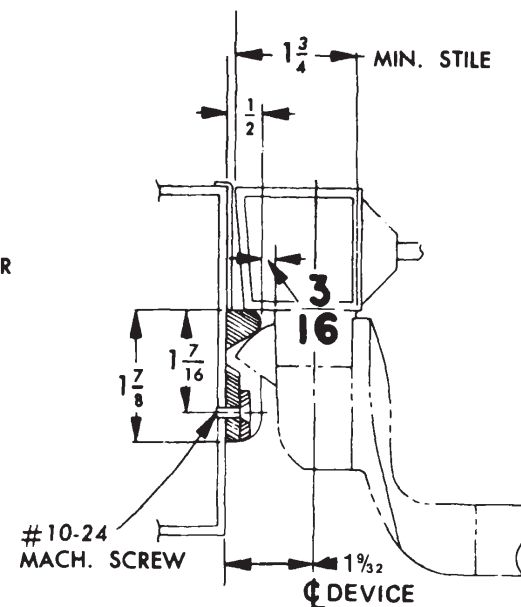

**ILLUST. 4 1409 STRIKE SINGLE DOOR NARROW STILE**

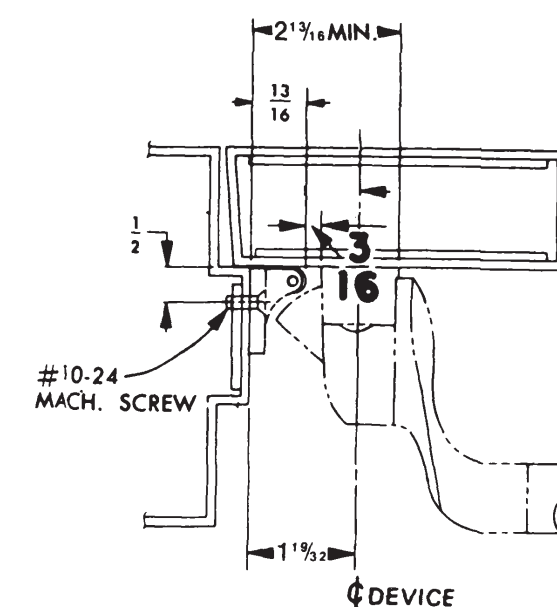

**299 STRIKE SINGLE DOOR WIDE STILE ILLUST. 5**

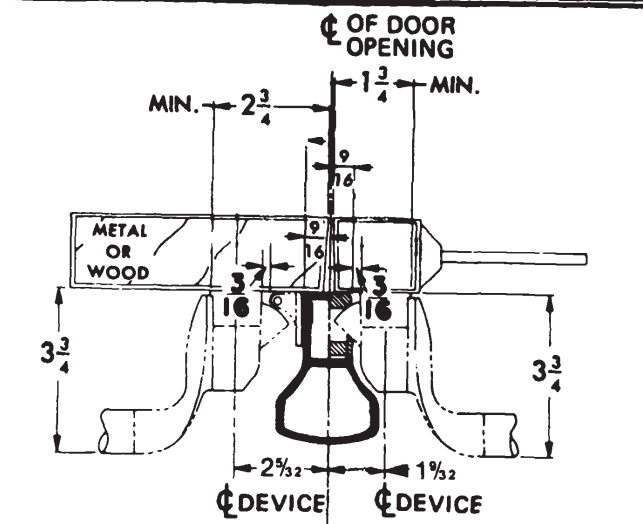

**ILLUST. 1 5254 OR 5654 MULLION WITH 299 STRIKE 5554 OR 5754 MULLION WITH 1408 STRIKE**

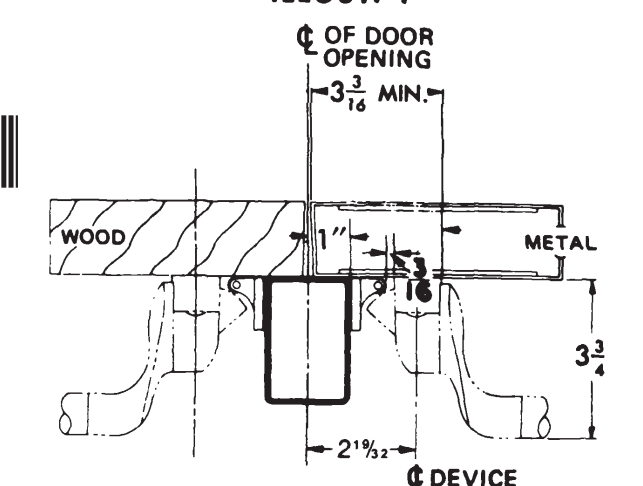

**ILLUST. 2 4954 MULLION WITH 299 STRIKE**

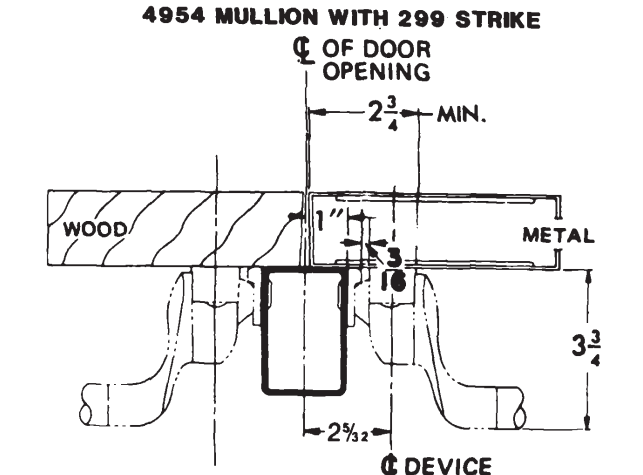

**ILLUST. 3 1654 MULLION WITH 1606 STRIKE**

SINGLE DOOR OPENING 39-13/16 TO FINISHED FLOOR	
DOUBLE DOOR OPENING WITH VON DUPRIN MULLION AND THRESHOLD	
THRESHOLD	39-11/16
NO THRESHOLD (FLAT SILL)	39-11/16

**STD APPLICATION**  
3/8 DIA. THRU ENLARGE TO 13/32 DIA OUTSIDE FACE OF DOOR FOR SEX BOLTS 2 HOLES

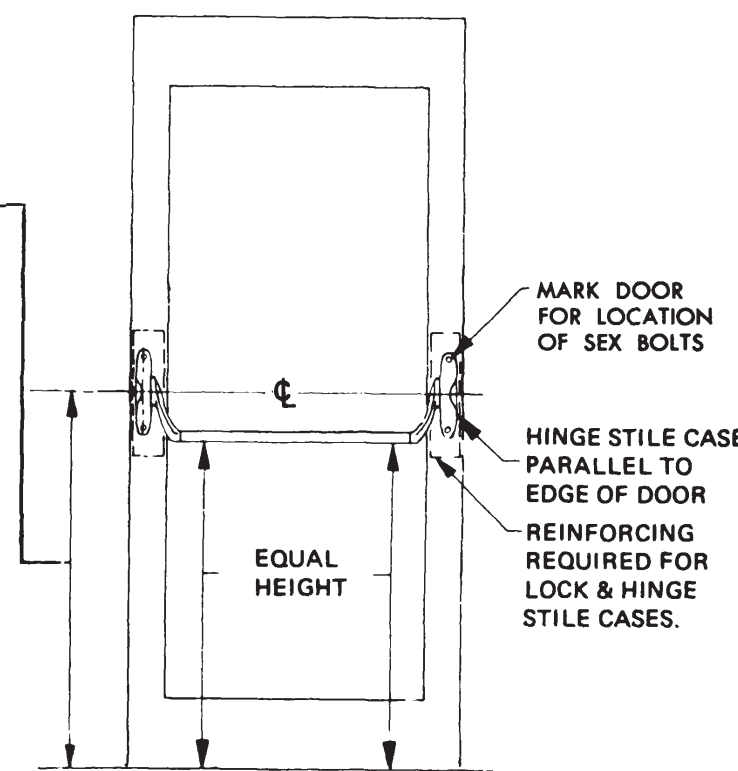

**ILLUST. 4**

**Customer Service**  
1-877-671-7011 www.allegion.com/us

<b>DESCRIPTION</b>	<b>VON DUPRIN</b>
55NL SERIES RIM DEVICE	DIRECTION NUMBER 911062-00 (b) DATE 06/14

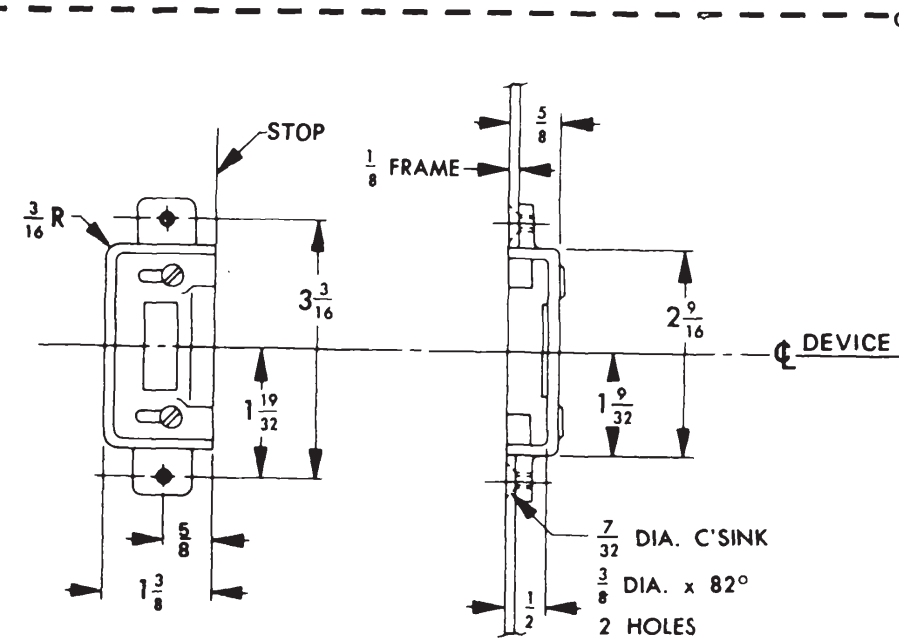

**1410 STRIKE**

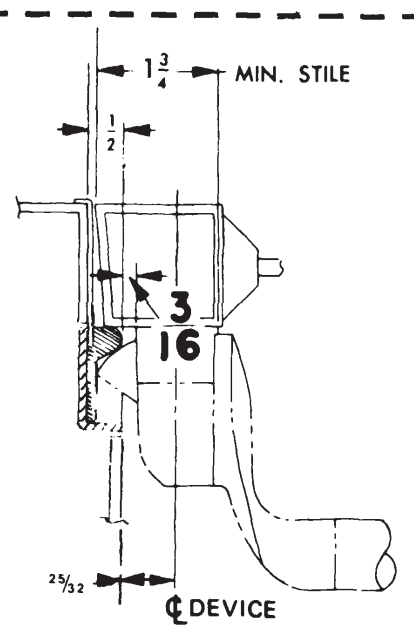

**ILLUS. 6 1410 STRIKE SINGLE DOOR NARROW STILE**

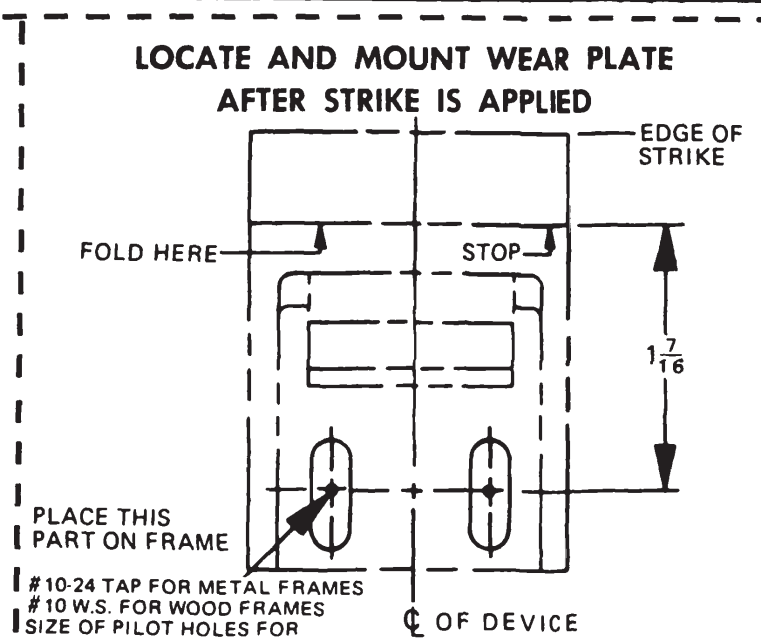

**1409 STRIKE TEMPLATE NO. 3**

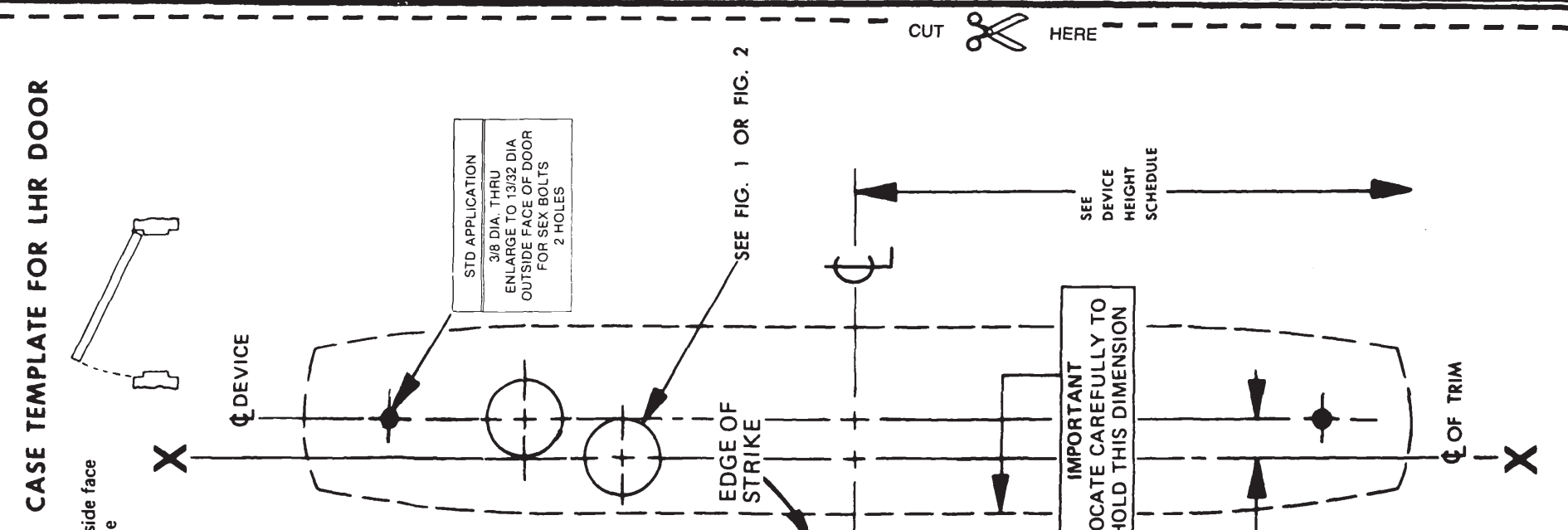

**LOCK CASE TEMPLATE FOR LHR DOOR**

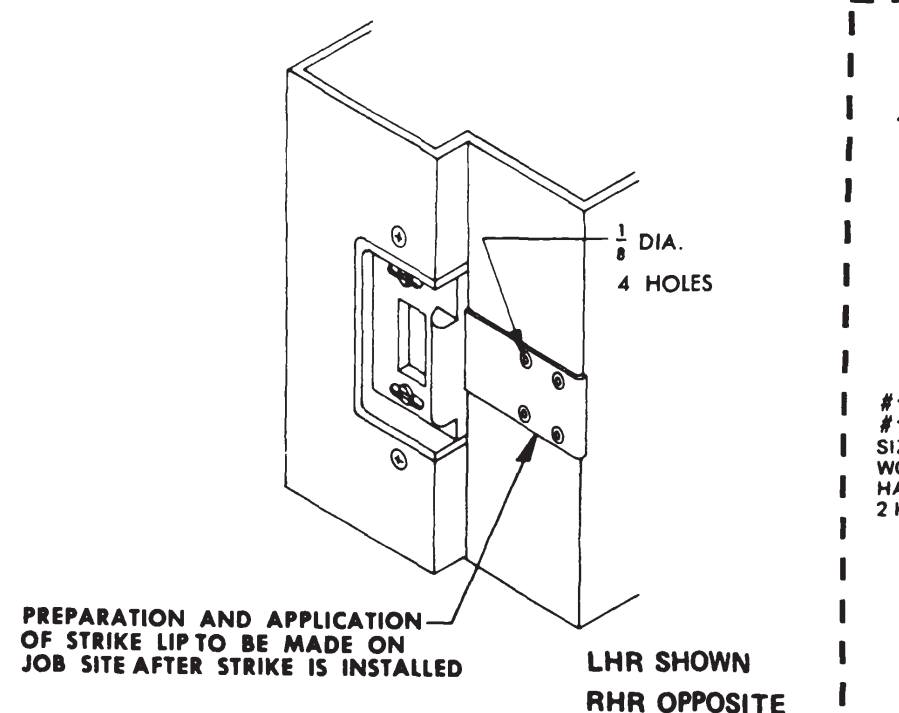

**1606 STRIKE TEMPLATE NO. 5**

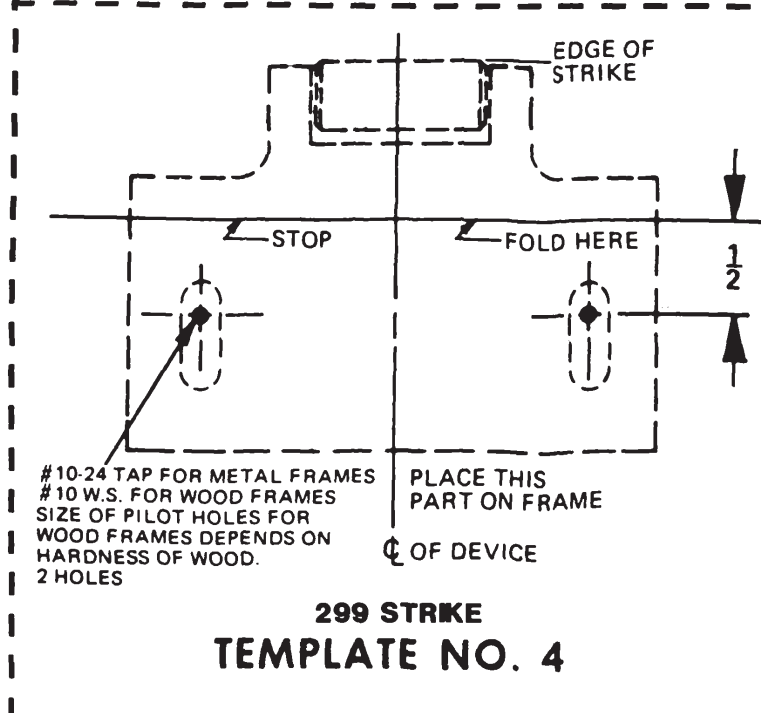

**299 STRIKE TEMPLATE NO. 4**

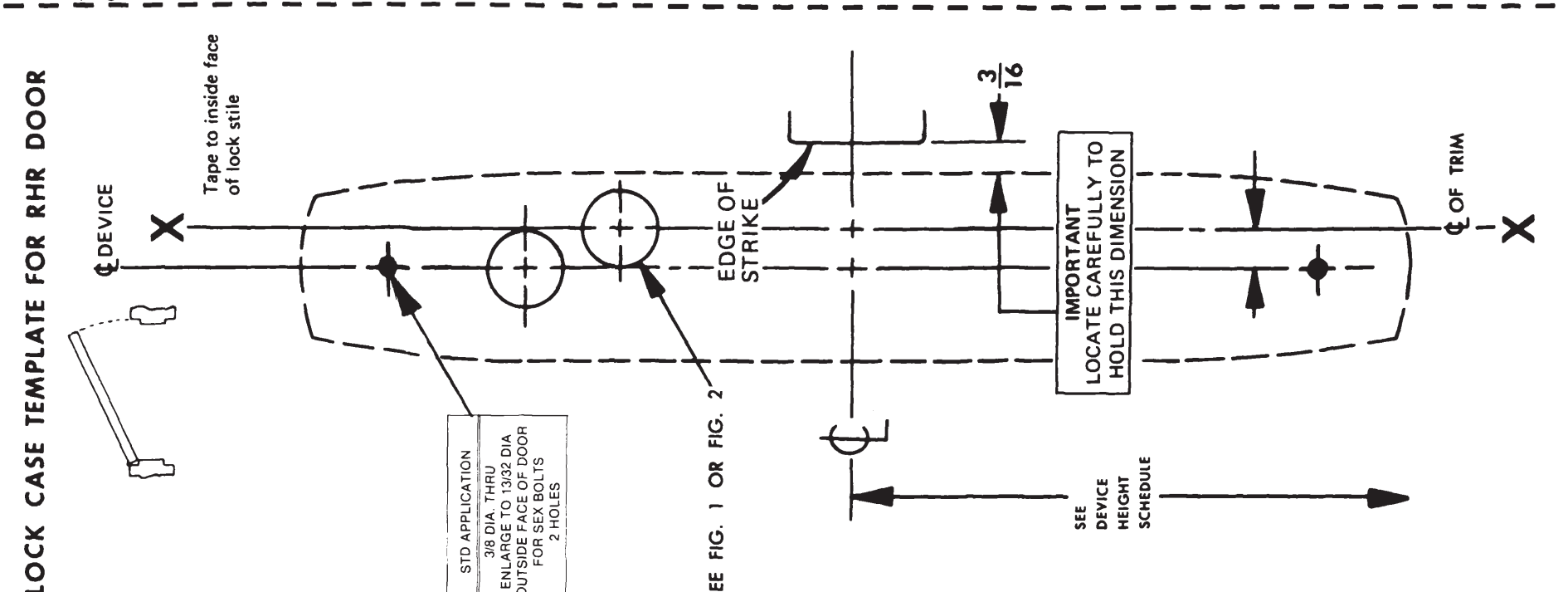

**LOCK CASE TEMPLATE FOR RHR DOOR**

**PREPARATION AND APPLICATION OF STRIKE LIPTO BE MADE ON JOB SITE AFTER STRIKE IS INSTALLED**

**LHR SHOWN RHR OPPOSITE**

**TEMPLATE NO. 1**

**TEMPLATE NO. 2**