

INSTALLATION DIRECTIONS

BEFORE APPLYING THIS DEVICE

- A. Threshold (if any) must be installed.
- B. Doors must be fitted and hung.
- C. Check that handing of hardware corresponds to handing of door.
- D. Apply Astragal (if any). See template No. 40106 for applying Astragal.

1. PREPARE DOOR

- A. Tape template No. 1 to inside face of lock stile. Be sure centerline "X-X" of template is parallel to edge of door and backset is as shown in schedule. Be sure centerline device is 39 13/16" to finished floor.
- B. Prepare door as shown. See Fig. 1 for wood door application and Fig. 2 for metal door application.

NOTE: SEX BOLTS ARE FURNISHED FOR WOOD, FORMICA, AND STEEL COVERED COMPOSITE DOORS. SEE FIG. 6

2. APPLY OUTSIDE TRIM

- A. See directions in trim carton. Line "X-X" on 1 in template corresponds to line "X-X" on device template and is parallel to edge of door. Transfer line "X-X" from inside face to outside face of door.
- B. Prepare outside face of lock stile.
- C. Cut off cylinder tailpiece if necessary, to extend 1/4" to 1/2" beyond inside face of door end into device case.

3. INSTALL LEVER ARMS

- A. Insert lever arms into lock stile and hinge stile cases.
- B. Assemble axes and tighten securely. (See instructions in axle envelope.)

4. APPLY LOCK STILE CASE

- A. Attach lock stile to door. See Fig. 1 or 2.

5. APPLY HINGE STILE CASE AND CROSSBAR TUBE (FIG. 7)

- A. Slip crossbar tube on lock stile and hinge stile lever arms. (See Direction No. 941009 for cutting crossbar, if necessary.)
- B. Be sure crossbar is level and hinge stile case is parallel to edge of door and approximately on centerline of exposed stile.
- C. Using holes in hinge stile case, mark location and prepare door for attaching screws.
- D. Apply hinge stile case with crossbar in place.
- E. Tighten wedge-tite set screws securely with dog key and screwdriver or equivalent for leverage and test crossbar for free action. (See Direction No. 941009 for these instructions.)

6. INSTALL SOFFIT LATCH BOLT ASSEMBLY (FIG. 6)

- A. Block door in open position.
- B. Install latch bolt as shown.

7. APPLY TOP LATCH CASE (FIG. 9)

- A. Close door against stop.
- B. Tape template No. 3 to door and stop.
- C. Prepare door for latch case and apply.

8. APPLY PLUNGER RELEASE BRACKET (FIG. 8)

- A. Close door against stop.
- B. Position backset to depress plunger, and allow rods to fall into engaged position.
- C. Tighten bracket mounting screws.

9. APPLY TO ROD

- A. Block door in open position.
- B. Check rod for correct length. See instruction sheet 0836 for cutting 88 vertical rods.
- C. Drive in top rod connector.
- D. Attach top rod with rod guide. (See Fig. 3) adjust rod length so connector fits as shown (Fig. 4)
- E. Check top rod for full retraction of latch bolt. Top rod should be flush to 1/16" above latch release surface.

10. APPLY BOTTOM LATCH CASE

- A. Close door against stop so top bolt engages.
- B. Tape template No. 2 to door and floor indicated on template.
- C. Prepare door for latch case and floor or threshold for strike and apply.

11. APPLY BOTTOM ROD

NOTE: DO NOT CUT BOTTOM ROD.

- A. Block door in open position.
- B. Retract bottom latch bolt.
- C. Adjust rod so rod connector fits as shown. (Fig. 5)
- D. Test door for top and bottom latch engagement.

12. APPLY TOP AND BOTTOM LATCH CASE COVER

13. APPLY COORDINATOR

NOTE: 1237 COORDINATOR MUST BE SURFACE APPLIED WHEN USED WITH 8813 & 8817 SERIES EXIT HARDWARE. SEE DIRECTIONS IN COORDINATOR PACKAGE.

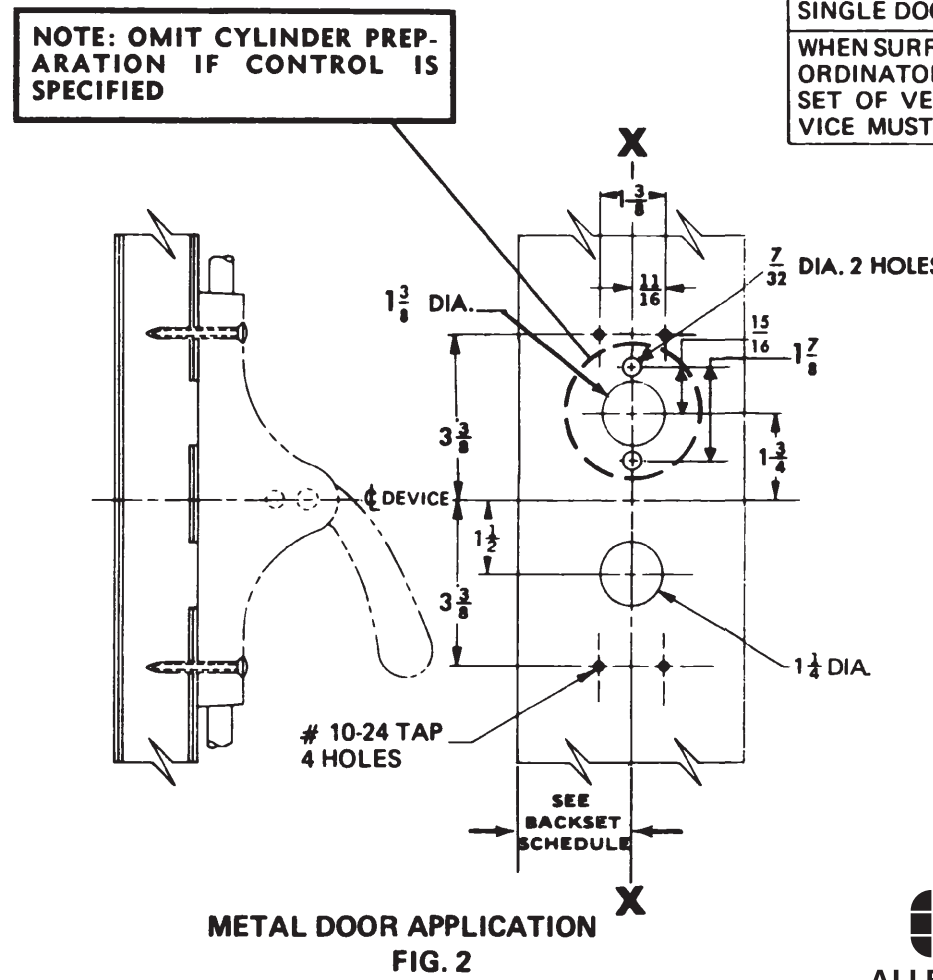
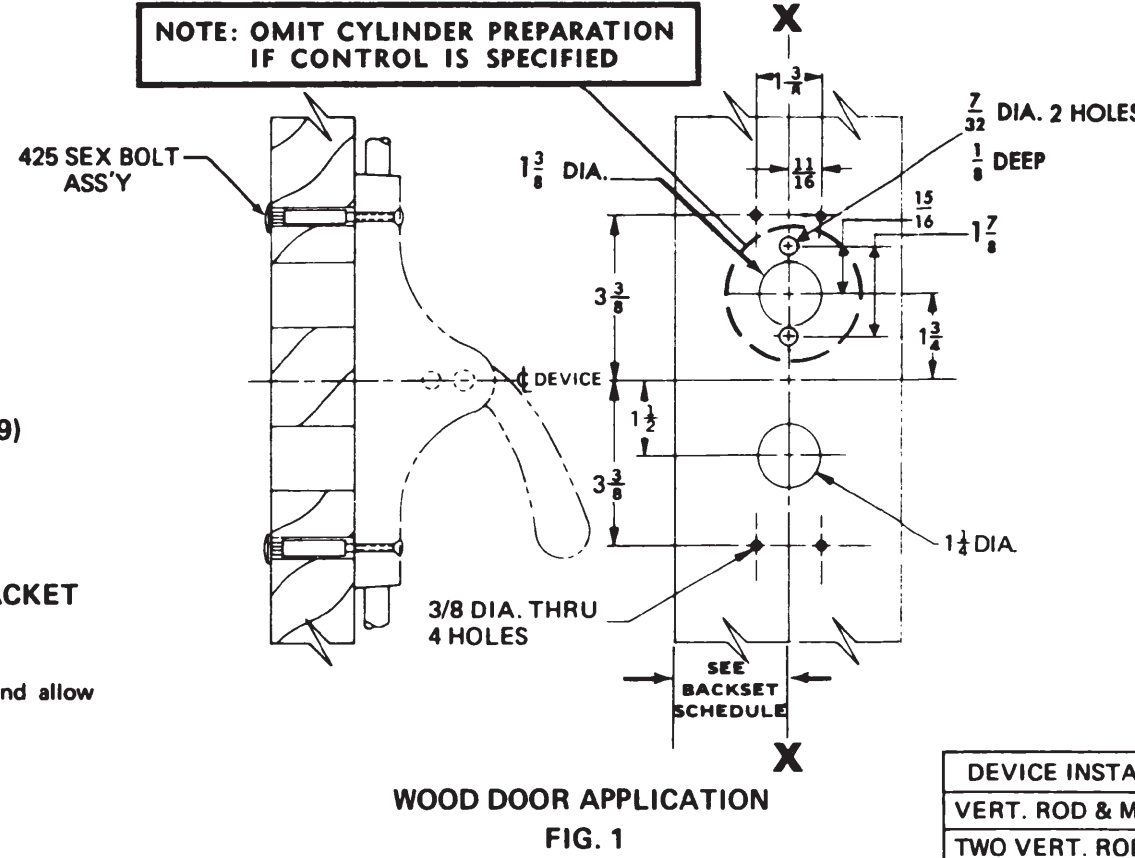

DEVICE INSTALLATION SCHEDULE	
VERT. ROD & MORT. DEVICE	2 3/4"
TWO VERT. ROD DEVICES	2 3/4"
SINGLE DOOR	2 3/4"
WHEN SURFACE APPLIED COORDINATOR IS USED BACKSET OF VERTICAL ROD DEVICE MUST BE	2"

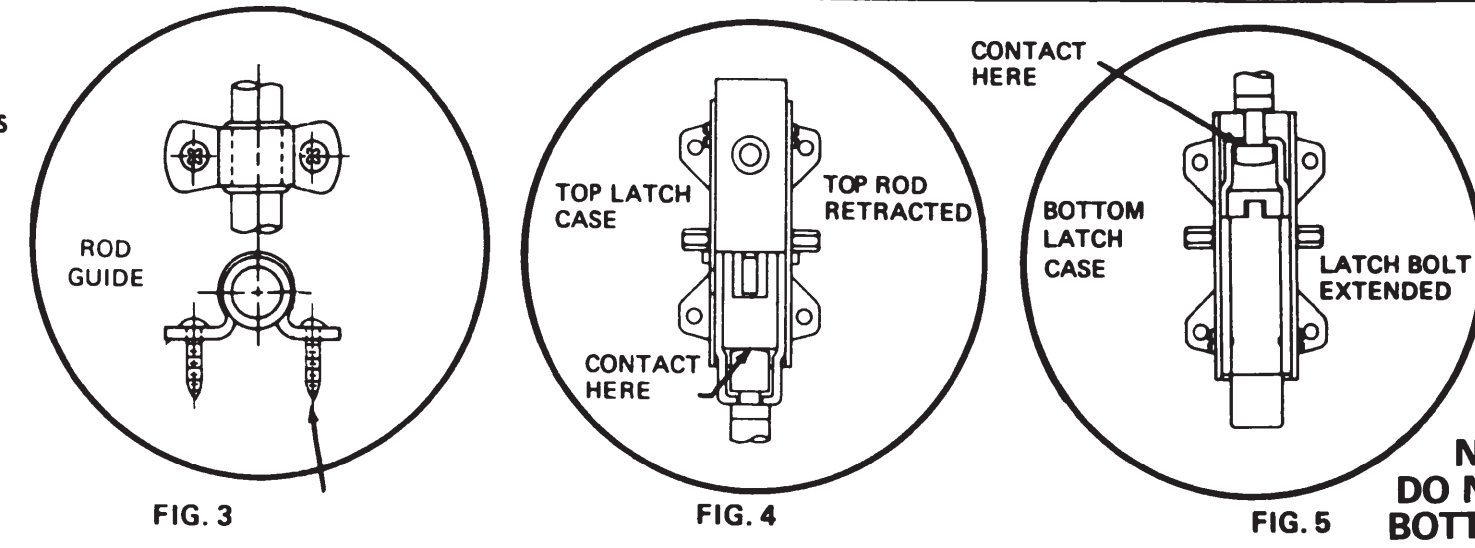

10-24 TAP FOR METAL DOORS.
10 W.S. FOR WOOD DOORS.
SIZE OF PILOT HOLES FOR WOOD DOORS DEPENDS ON HARDNESS OF WOOD
2 HOLES

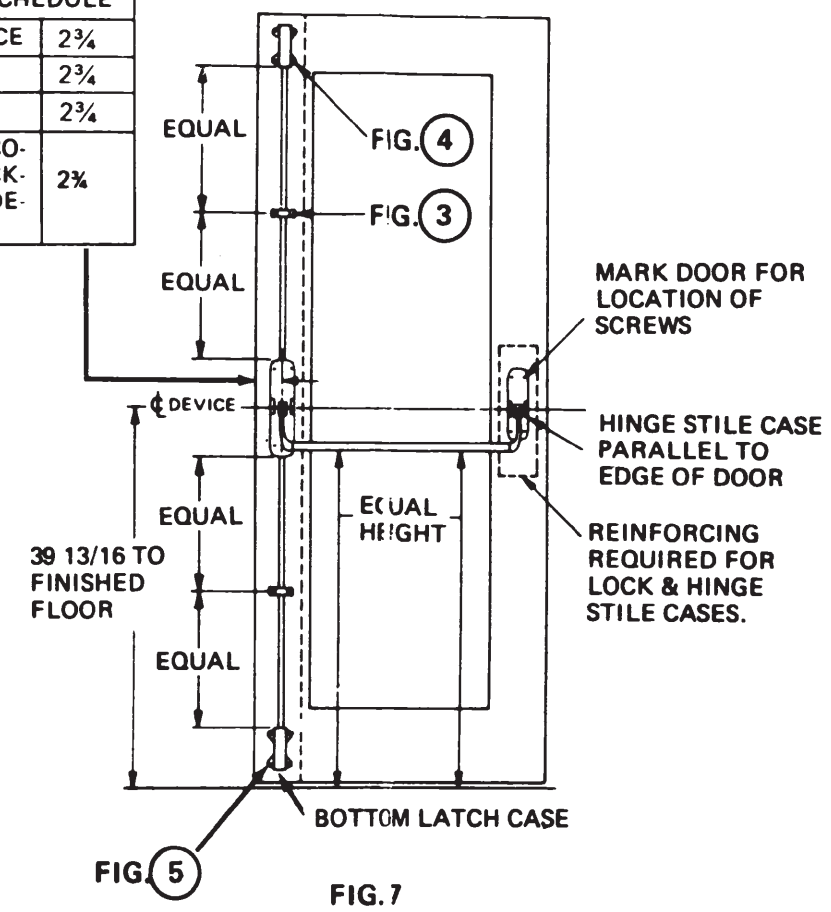

NOTE: MORTAR GUARD SHOULD BE PROVIDED TO PROTECT SOFFIT LATCH BOLT ASSEMBLY

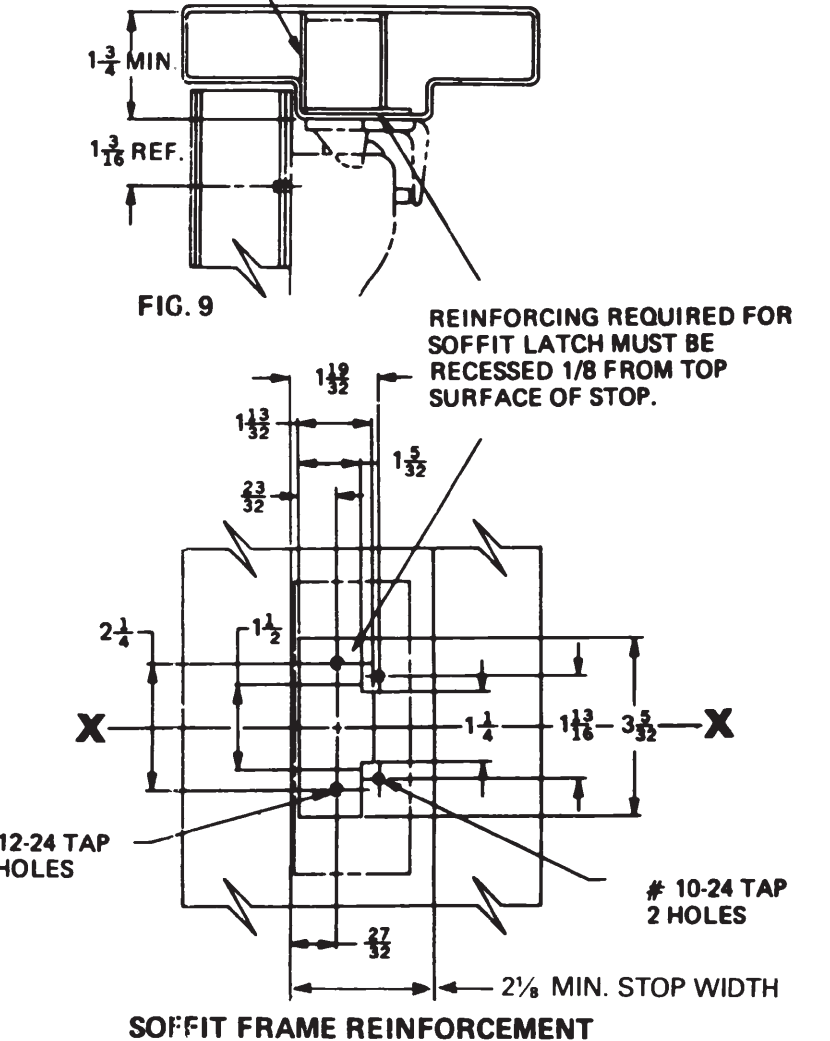

UL LISTED FIRE EXIT HARDWARE



Customer Service
1-877-671-7011 www.allegion.com/us

DESCRIPTION
8827K-F SURFACE APPLIED DEVICE

VON DUPRIN
DIRECTION NUMBER 911166-00(b) DATE Rev. 01/14

