

**INSTALLATION DIRECTIONS**

**BEFORE APPLYING THIS DEVICE**

- A. Threshold (if any) must be installed.
- B. Doors must be fitted and hung.
- C. Check that handing of hardware corresponds with handing of door.

**1. APPLY STRIKE**

- A. Tape appropriate strike template No. 3 or No. 4 depending on handing of door to stop.
- B. When Von Duprin Mullion is used apply strike at tapped holes in Mullion. (See illustration 1.)

**2. PREPARE DOOR**

- A. Tape full size template No. 1 or 2, depending on handing of door, to inside face of lock stile. Be sure center line of device is 39-13/16" from finished floor.

**NOTE** BE SURE CENTERLINE OF LOCK STILE CASE IS PARALLEL TO STOP AND THAT EDGE OF CASE IS 3/16" FROM EDGE OF STRIKE. STRIKE MUST BE SHIMMED OUT IF LOCK CASE IS MOUNTED MORE THAN 3/16" FROM STRIKE.

- B. Prepare door as shown. See Fig. 1 for wood door application, and Fig. 2 for metal door application.

**3. APPLY OUTSIDE TRIM IF REQUIRED**

- A. See directions in trim carton. Line "X-X" on trim template corresponds to line "X-X" on device template and is parallel to edge of door. Transfer line "X-X" from inside face to outside face of door.
- B. Prepare outside face of lock stile.
- C. Cut off cylinder tailpiece, if necessary, to extend 5/8 to 3/4 thru door and into device case.
- D. Apply outside trim.

**4. INSTALL LEVER ARMS**

- A. Insert lever arms into lock stile and hinge stile cases.
- B. Assemble axles and tighten securely. (See instructions in axle envelope.)

**5. APPLY LOCK STILE CASE**

- A. Remove key from cylinder.
- B. Attach lock stile case to door. (See Fig. 1 or Fig. 2)
- C. Test key action.

**6. APPLY HINGE STILE CASE AND CROSSBAR TUBE (FIG. 4)**

- A. Slip crossbar tube on lock stile and hinge stile lever arms. (See Direction No. 941009 for cutting crossbar, if necessary.)
- B. Be sure crossbar is level and hinge stile case is parallel to edge of door and approximately on centerline of exposed stile.
- C. Using holes in hinge stile case, mark location and prepare door for attaching screws.
- D. Apply hinge stile case with crossbar in place.
- E. Tighten wedge-tite set screws securely with dog key and screwdriver or equivalent for leverage, and test crossbar for free action. (See Direction No. 941009 for these instructions.)

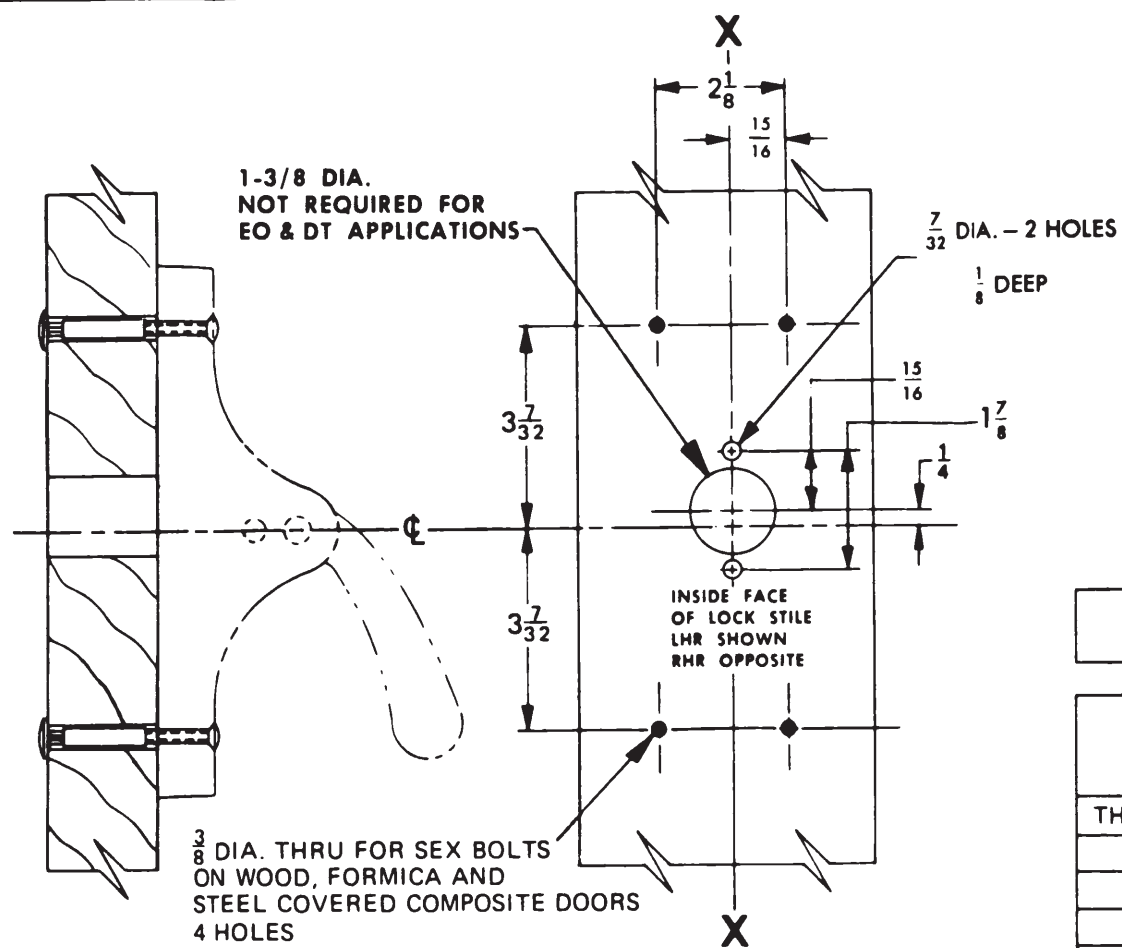

**WOOD DOOR APPLICATION  
FIG. 1**

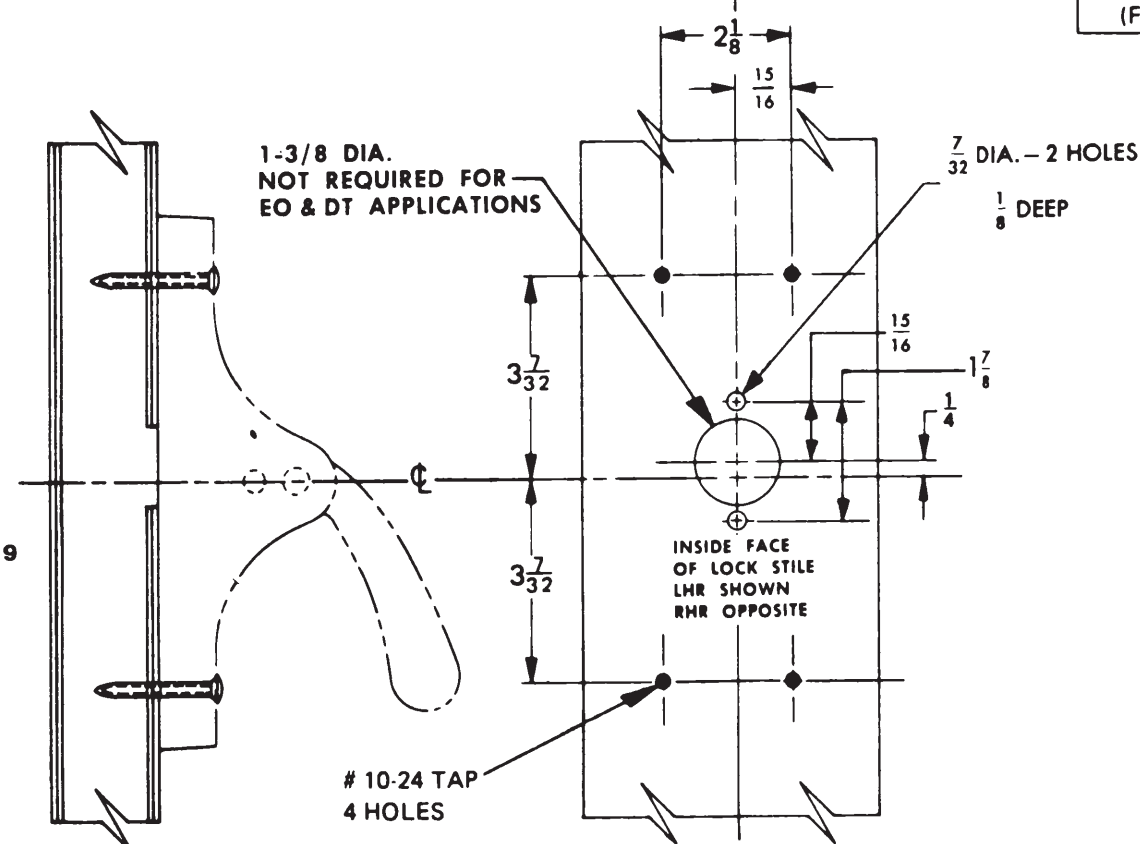

**METAL DOOR APPLICATION  
FIG. 2**

SINGLE DOOR OPENING 39-13/16 TO FINISHED FLOOR	
DOUBLE DOOR OPENING WITH VON DUPRIN MULLION AND THRESHOLD	
THRESHOLD NO.	TO FIN. FLOOR
350 or 360	} <b>39 13/16</b>
355 or 365	
390	
ALL OTHER THRESHOLDS	
NO THRESHOLD (FLAT SILL)	

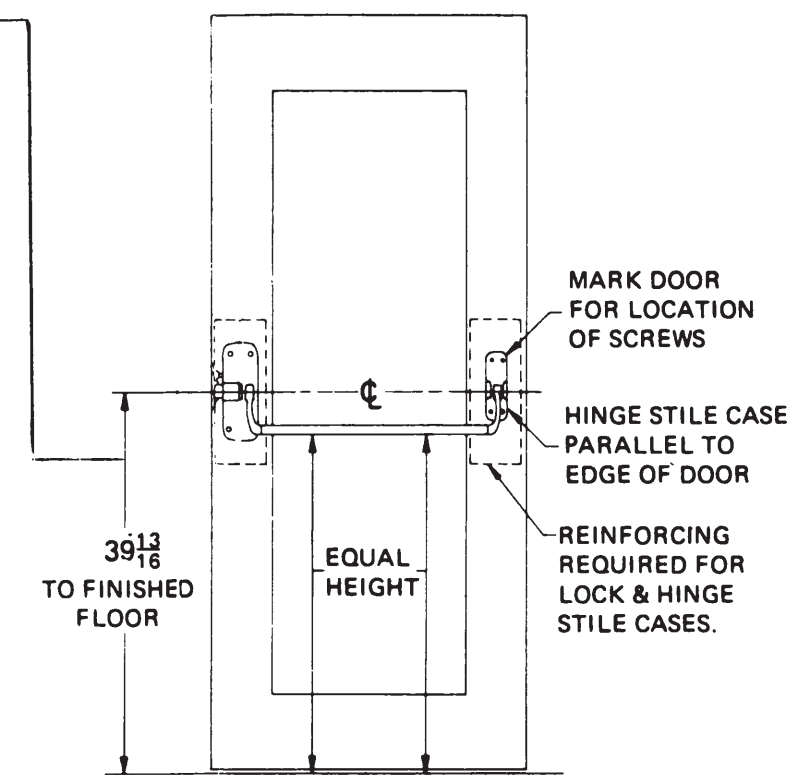

**FIG. 4**

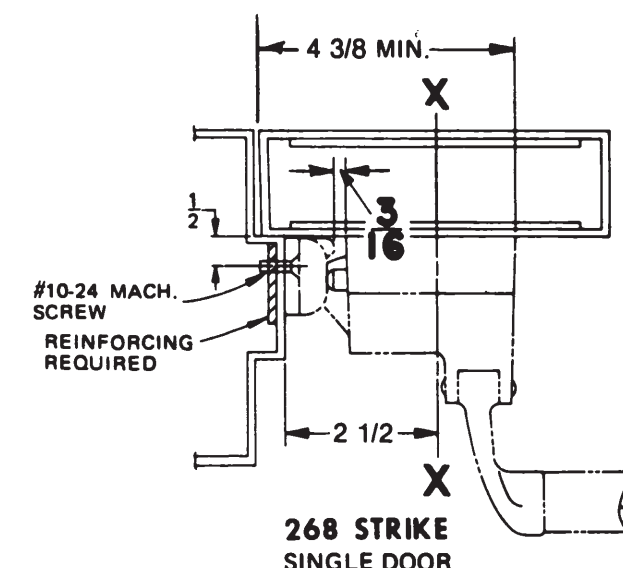

**268 STRIKE  
SINGLE DOOR**

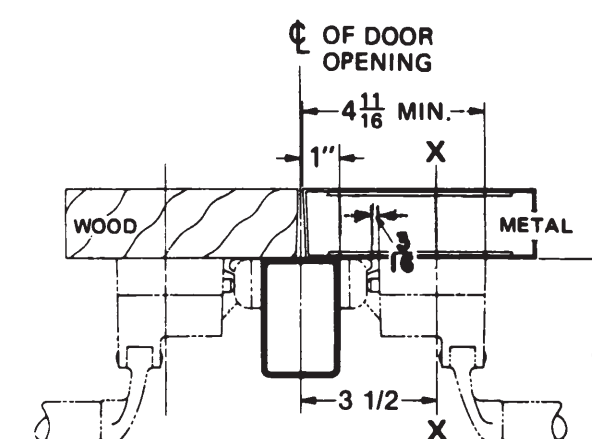

**ILLUST. 1  
9954 MULLION WITH 268 STRIKE**



Customer Service  
1-877-671-7011 www.allegion.com/us



911170-00

DESCRIPTION  
**88EO-F, 88DT-F & 88NL-F SERIES RIM DEVICES**

**VON DUPRIN**

DIRECTION NUMBER 911170-00 (b) DATE 06/14

FOR TRIM APPLICATION SEE DIRECTIONS  
IN TRIM CARTON IF REQUIRED.

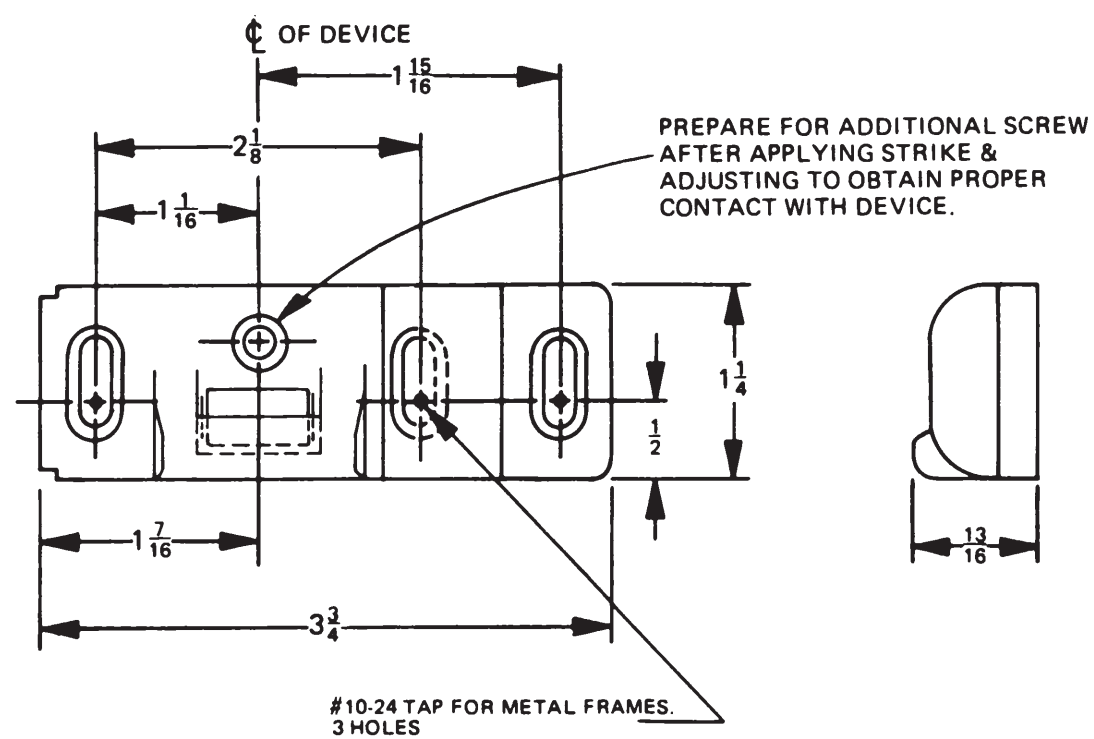

**268 STRIKE**

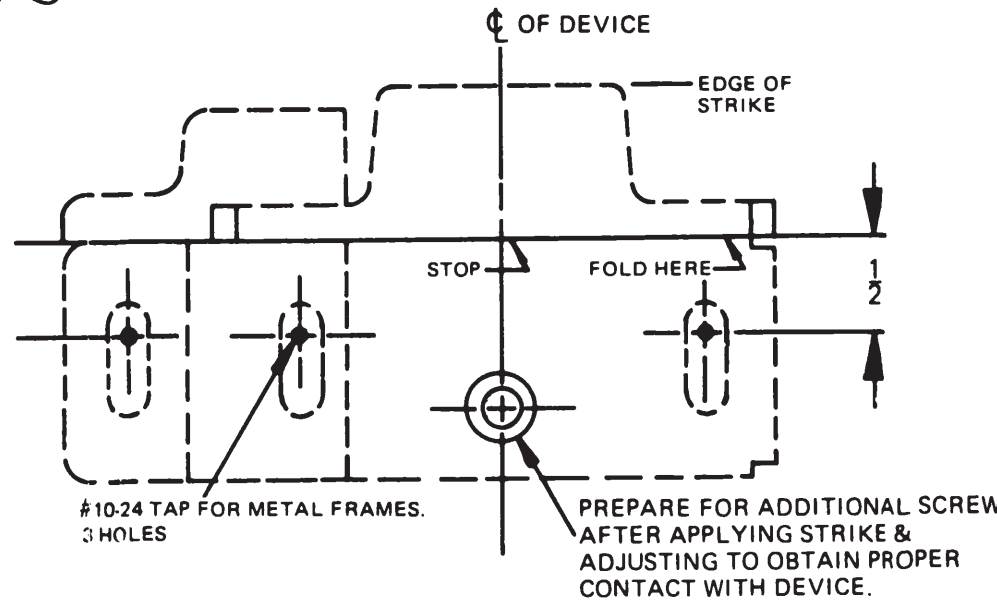

**268 STRIKE  
TEMPLATE NO. 3**

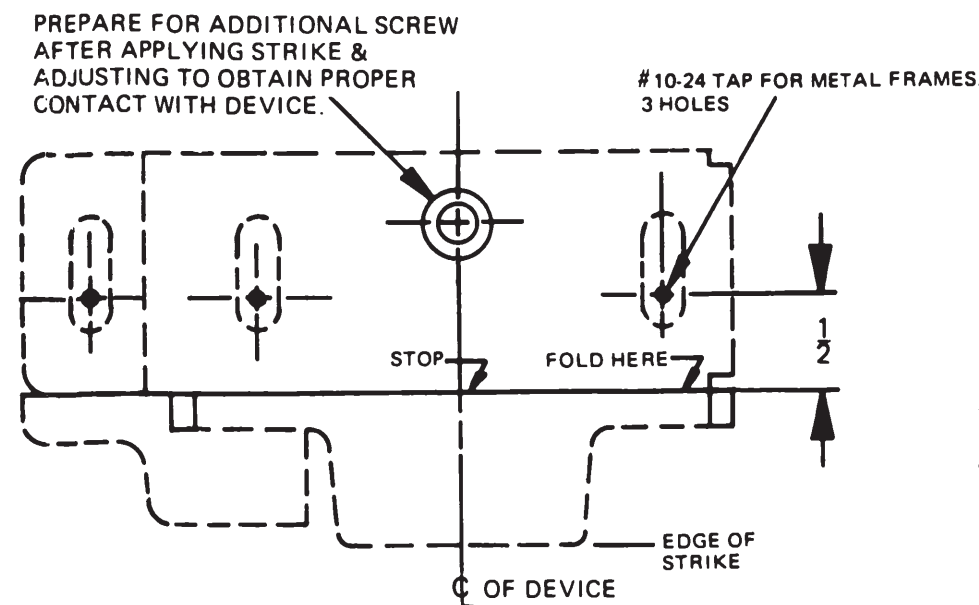

**268 STRIKE  
TEMPLATE NO. 4**

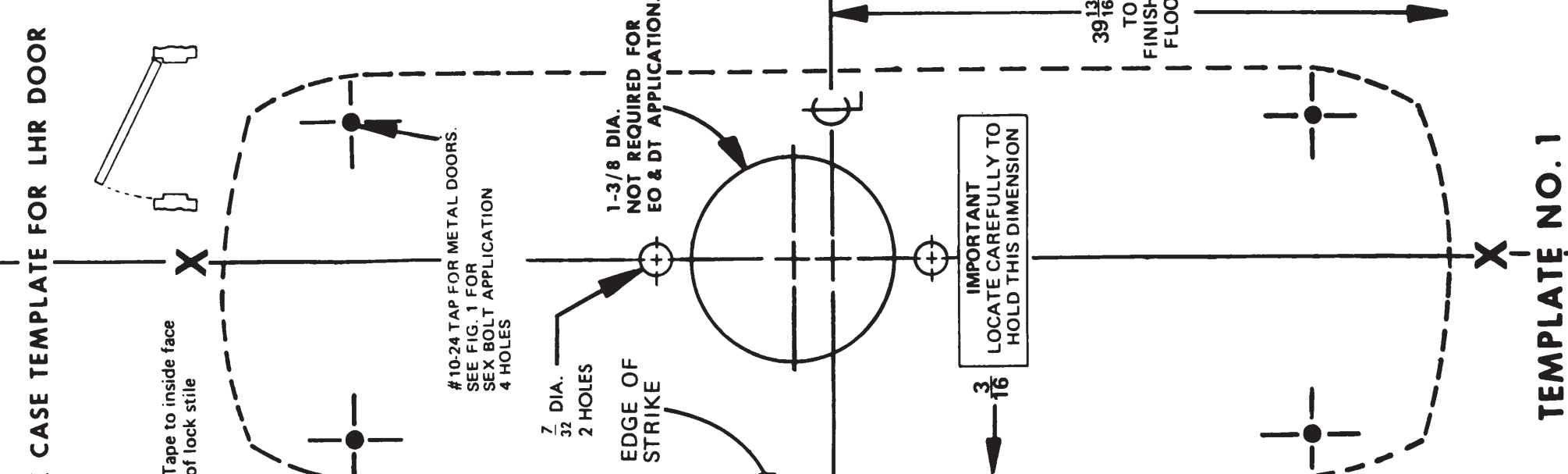

**LOCK CASE TEMPLATE FOR LHR DOOR**

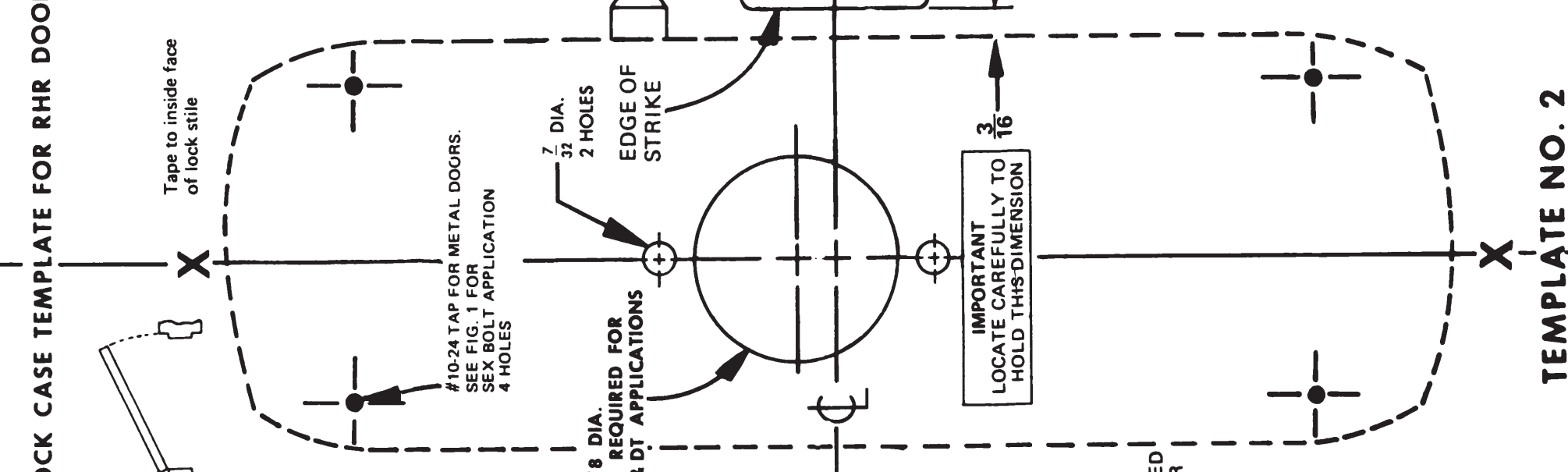

**LOCK CASE TEMPLATE FOR RHR DOOR**

TEMPLATE NO. 1

TEMPLATE NO. 2

LHR SHOWN  
RHR OPPOSITE