



911376-00

98/9947

VON DUPRIN®

Concealed Vertical Rod Exit Device
Metal Door Applications

Installation Instructions

Devices covered by these instructions:

- 98/9947/48 Concealed Vertical Rod Exit Device
- 98/9947-F/48-F (Fire) Concealed Vertical Rod Exit Device
- CD98/9947/48 (Cylinder Dogging) Concealed Vertical Rod Exit Device
- QEL98/9947/48/-F (Electric Latch Retraction) Concealed Vertical Rod Exit Device
- HH/HW98/9947/47-F (Hurricane) Concealed Vertical Rod Exit Device

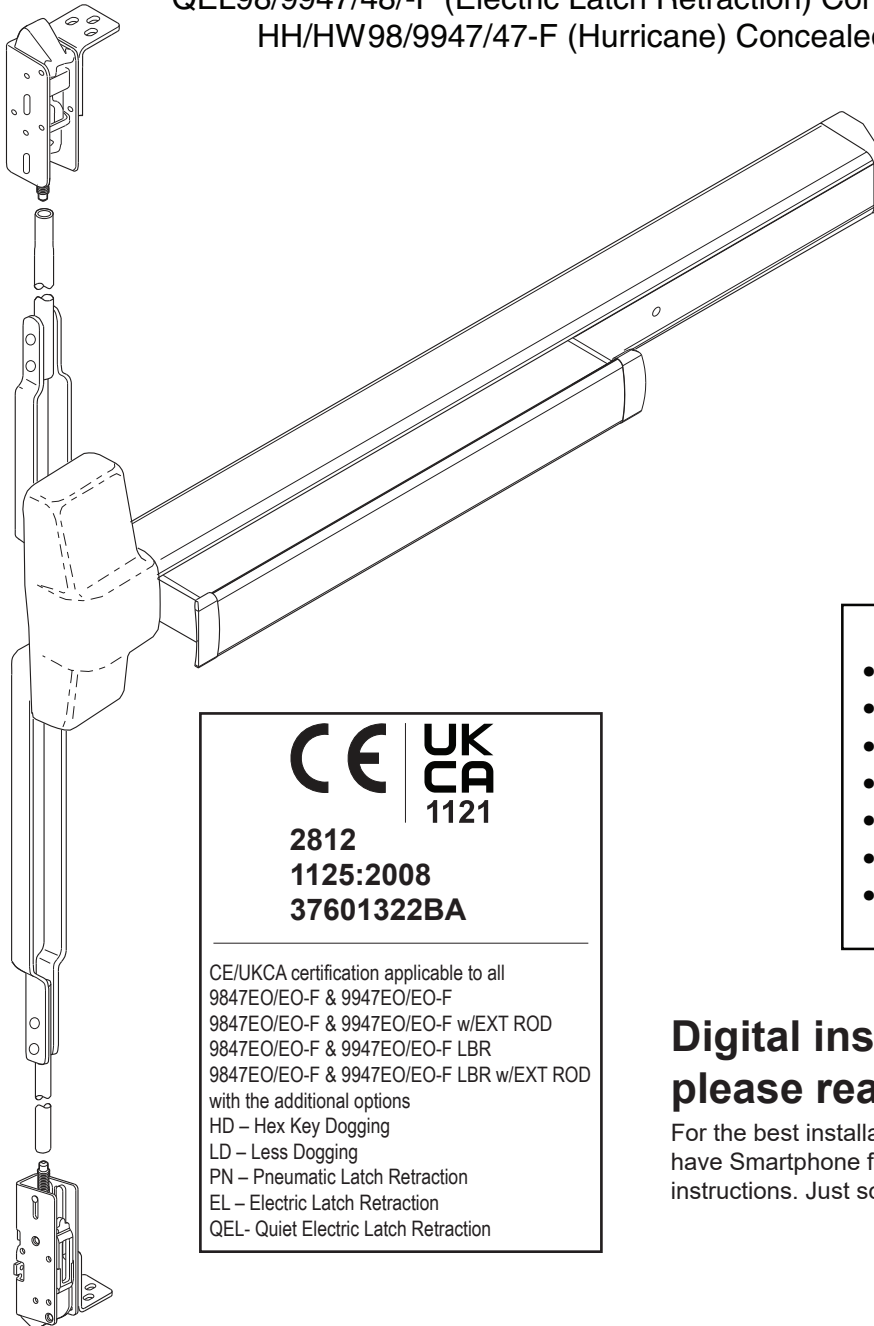

Special tools needed:

- 5/64" hex wrench
- #10-24 tap
- Drill bits: #25, 1/8", 1/4",
5/16", 13/32"

Index:

• Screw chart	2
• Door preparation chart	3
• Device installation	4-6
• Adjust rods	7
• Frame preparation chart	7
• Optional equipment	8
• Cut device	8



2812
1125:2008
37601322BA

CE/UKCA certification applicable to all
 9847EO/EO-F & 9947EO/EO-F
 9847EO/EO-F & 9947EO/EO-F w/EXT ROD
 9847EO/EO-F & 9947EO/EO-F LBR
 9847EO/EO-F & 9947EO/EO-F LBR w/EXT ROD
 with the additional options
 HD – Hex Key Dogging
 LD – Less Dogging
 PN – Pneumatic Latch Retraction
 EL – Electric Latch Retraction
 QEL- Quiet Electric Latch Retraction

Digital instructions - please read

For the best installation experience, we now have Smartphone friendly digital interactive instructions. Just scan the QR code.



alle.co/9947









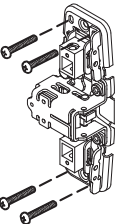
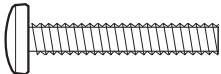
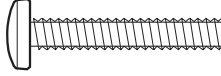
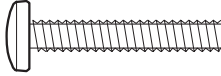
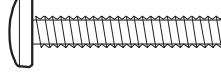
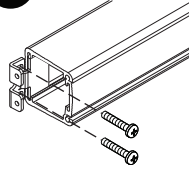
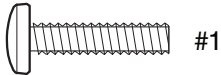
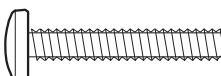

For hurricane rated device requirements, see page 4.

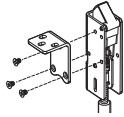

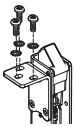
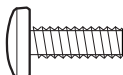
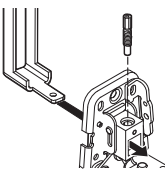
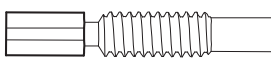
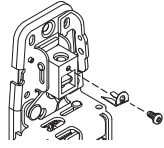
Customer Service

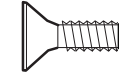
1-877-671-7011 www.allegion.com/us

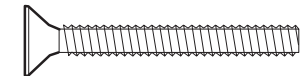
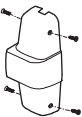
SCREW CHART

<p>A</p> 	 <p>#10-24 x 1"</p>	<p>Surface mount or Sex bolts (1-3/4" door)</p>
	 <p>#10-24 x 1-1/2"</p>	<p>Sex bolts (2-1/4" door)</p>
	<p>- Packaged with trim -</p>	
	 <p>#10-24 x 1-3/8"</p>	<p>990 trims (1-3/4" door)</p>
	 <p>#10-24 x 1-7/8"</p>	<p>990 trims (2-1/4" door)</p>
<p>B</p> 	 <p>#10-24 x 3/4"</p>	<p>Surface mount or Sex bolts (1-3/4" door)</p>
	 <p>#10-24 x 1-1/8"</p>	<p>Sex bolts (2-1/4" door)</p>
<p>C</p> 	 <p>#10-16 X 3/8" Thread cutting</p>	<p>End cap</p>
<p>D</p> 	 <p>#10-32 X 1/4"</p>	<p>Bracket to latch</p>
<p>E</p> 	 <p>#10-24 X 1/2"</p>	<p>Bracket to door</p>
<p>F</p> 	 <p>Rod adjusting screw</p>	<p>Retaining clip</p>
<p>G</p> 	 <p>#8-32 X 5/16"</p>	<p>Retaining clip</p>
<p>H</p> 	 <p>#10-24 X 1/2"</p>	<p>338 strike</p>
<p>I</p> 	 <p>#10-24 X 1-1/2"</p>	<p>Ratchet release</p>
<p>J</p> 	 <p>#8-18 x 3/8" Thread cutting</p>	<p>Center case cover</p>

DOOR PREPARATION CHART

Go to instructions on next page before using preparation chart

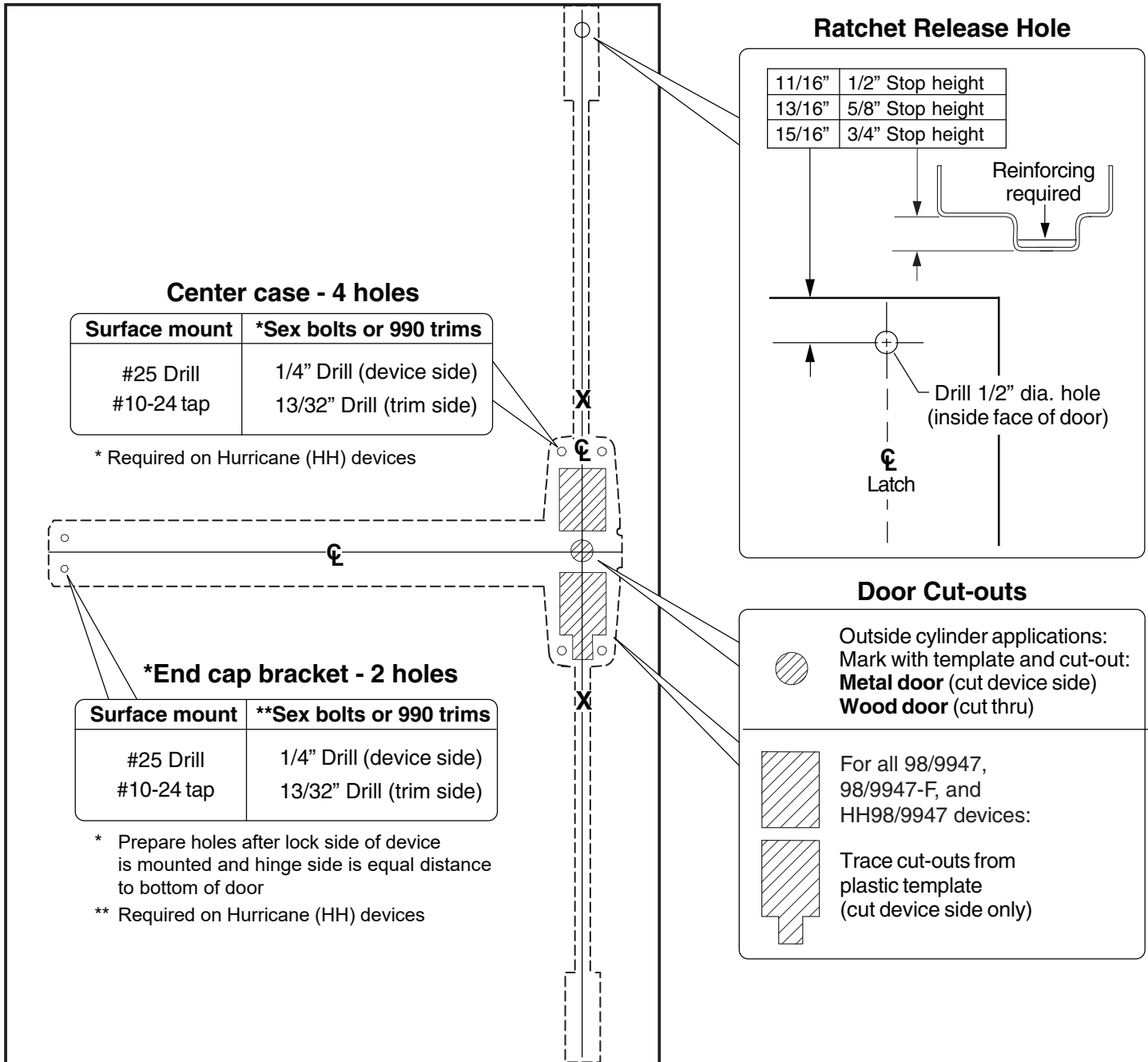

Latch Cases

(Drill top and bottom of door)

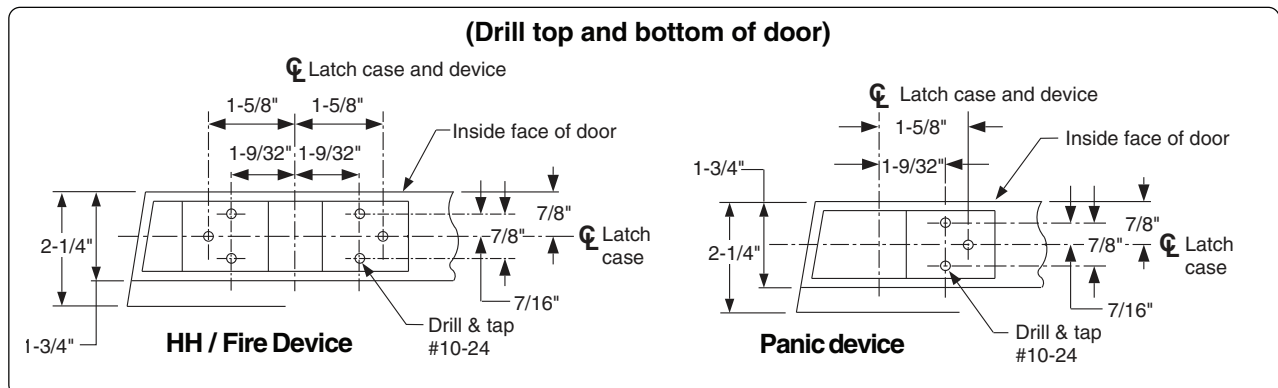

HURRICANE RATED DEVICE REQUIREMENTS

Hurricane rated exit device requirements (when used with approved Allegion door applications)

Sexbolts		When installing a Wind and Impact-rated hurricane device (HH), sex bolts must be used. Sex bolts are noted throughout the instructions where applicable. If through-bolting trims are used, these trims are equivalent in function and are used in place of sex bolts.		
Application		Single door standard strike	Mullion	Double door standard strike
HH (Wind and Impact rated) or HW (Wind Only)	HH98/9947, 98/9947	Top: 338 Bottom: 304L	—	Top: 338 Bottom: 304L
	98/9947-F	—	—	

1 Draw Horizontal Device Center Line (☉)

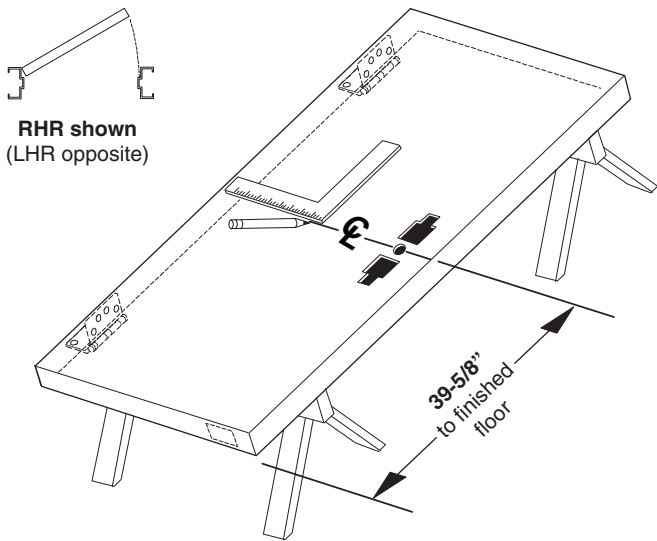

3 Prepare Door per Preparation Chart on Page 3

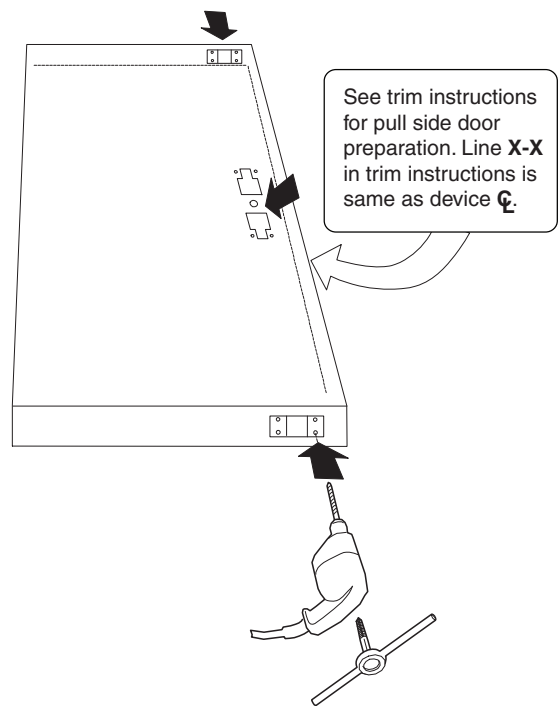

2 Determine Correct Backset, then Mark 4 Holes for Device Center Case Using Template

98/9947
(non-fire rated device)
single or double door

98/9947-F
(fire rated device)
or **98/9947**
double door with
98/9975 (mortise device)
on opposite door
or **HH98/9947**
(hurricane rated device)

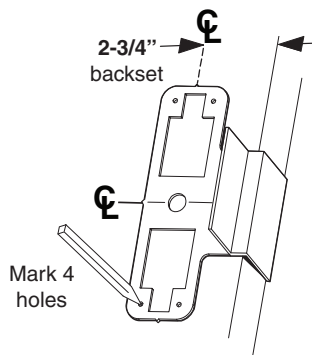
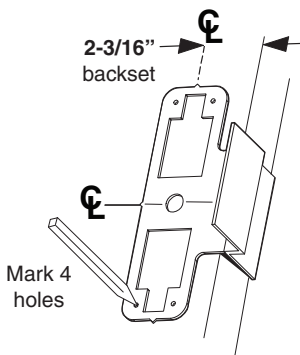

4 If Necessary, Remove NL Drive Screw

NL drive screw

Factory installed on back of center case

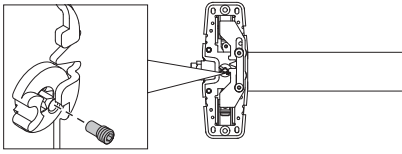

With the NL drive screw removed, key locks and unlocks lever, knob, or thumb piece. For the trims listed below, **REMOVE** NL drive screw.

996L 696TP 990TP 996K 697TP

With the NL drive screw installed, key retracts latch bolt. **DO NOT** remove NL drive screw for the following applications:

NL, EO, DT trims and 98/99-2 double cylinder devices (i.e. TP-2, L-2, and K-2).

*996L-BE *E996L *696TP-BE *990TP-BE
*996K-BE *E996L-BE *697TP-BE

* If the trim being installed is "BE" (i.e. 996L-BE), the trim lock tumbler on the back of the device must be in the **UP** position before device is installed. This allows the trim to be unlocked at all times.

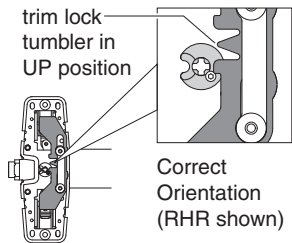

Correct Orientation (RHR shown)

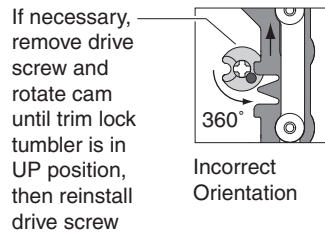

Incorrect Orientation

If necessary, remove drive screw and rotate cam until trim lock tumbler is in UP position, then reinstall drive screw

5 If Using a Cylinder with a Tailpiece, Prepare Device and Cylinder

a. Install tailpiece guide.

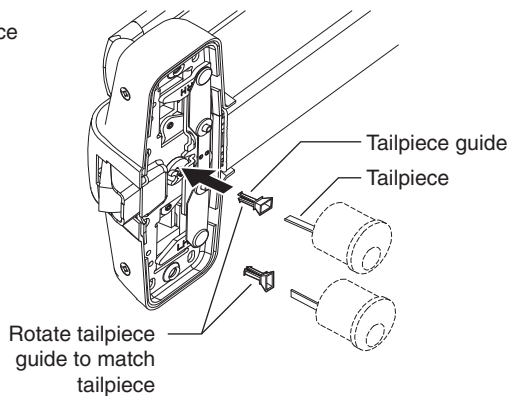

Rotate tailpiece guide to match tailpiece

b. Cut tailpiece as needed.

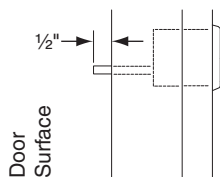

6 Assemble Rods and Latches and Adjust Length for Proper Door Height

Follow red and blue instruction cards on rods to set initial rod length

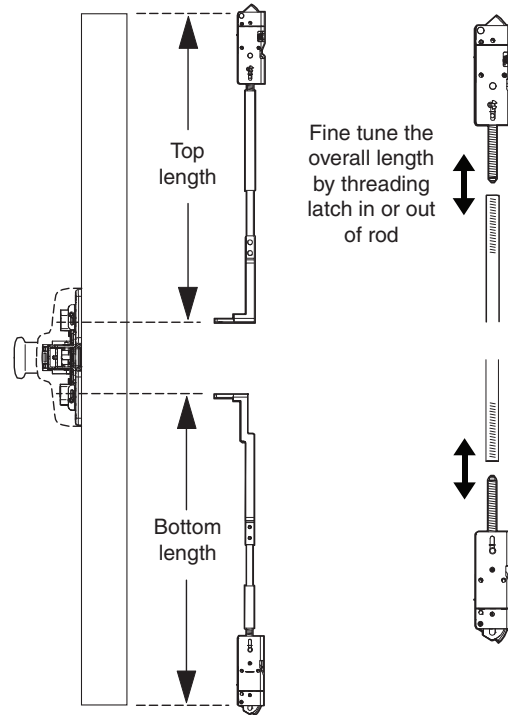

7 Install Rods and Latches as Shown

Note: Fire / HH devices use brackets on both sides of latches

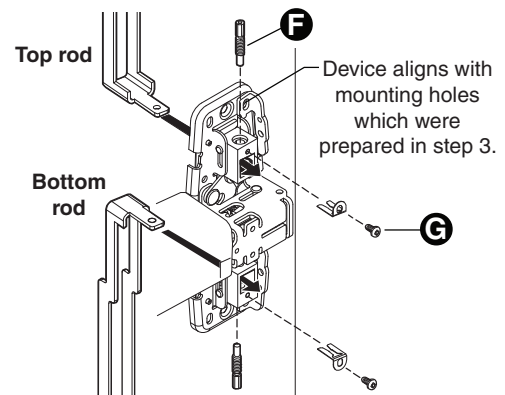
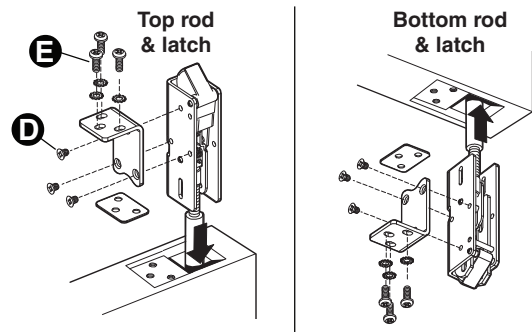

8 Secure Device to Door as Shown, then Hang Door on Frame

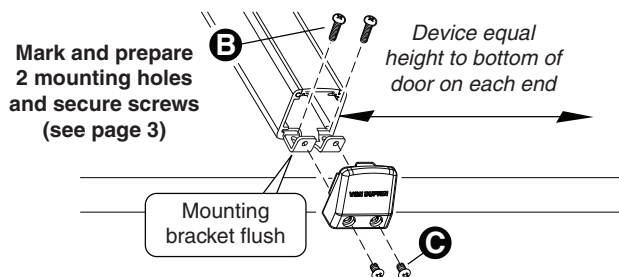
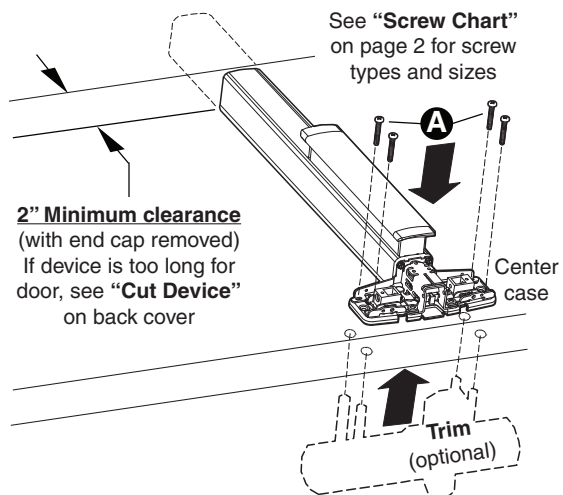

9 Install Top Strike and Ratchet Release

338 Top strike

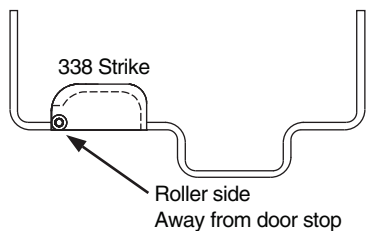
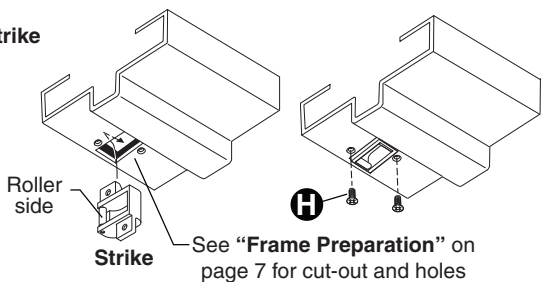

Ratchet release

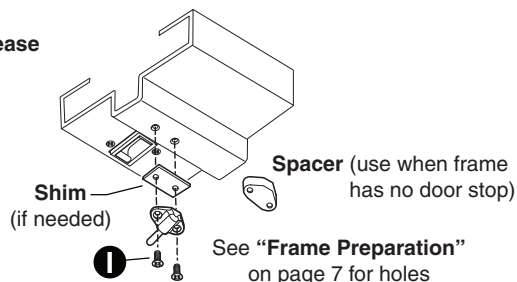

10 Install Bottom Strike or Prepare Threshold

385-A bottom strike

1/4" undercut for 98/9947A
3/4" max undercut for 98/9948A

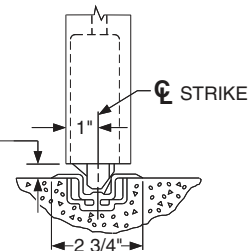

Threshold application

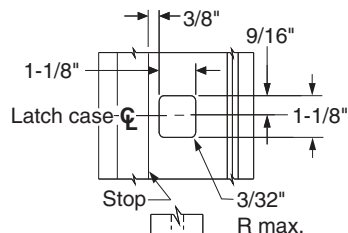

Flat threshold application

Remove material as necessary to accommodate 5/8" latch bolt throw

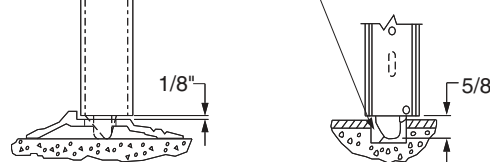

304L strike

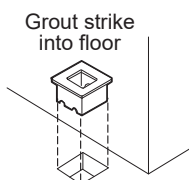

Hurricane applications use threshold with 304L bottom strike

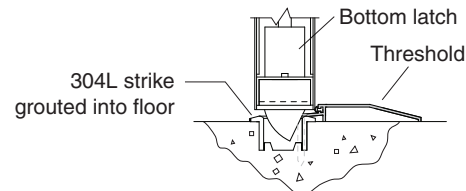

11 Adjust Rods and Install Center Case Cover

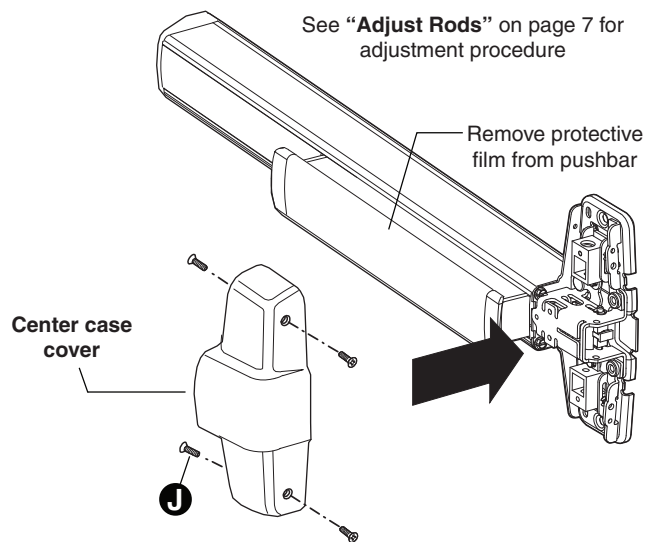

ADJUST RODS

1. Open door and release top latch bolt as shown (Figure 1).

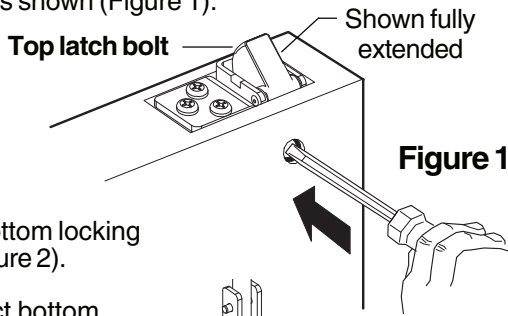

2. Loosen bottom locking screw (Figure 2).
3. Disconnect bottom vertical rod by removing bottom adjusting screw.
4. Loosen top locking screw.
5. Rotate top adjusting screw clockwise until top latch bolt is fully extended (Figure 1).
6. Check top latch bolt for deadlocking (latch bolt should not push in).
7. Turn top locking screw in. Do not over-tighten.

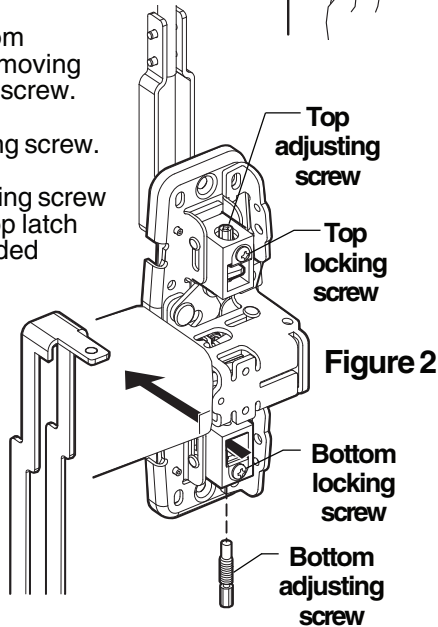

8. Depress pushbar and release.

9. Make sure top latch bolt stays retracted as shown.

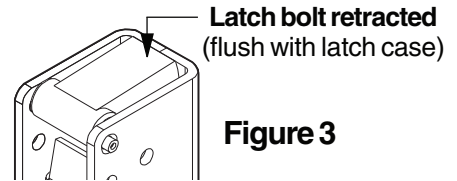

10. Install bottom adjusting screw through bottom rod (Figure 2).
11. With top latch bolt still retracted, adjust bottom rod so latch bolt clears floor and bottom strike.

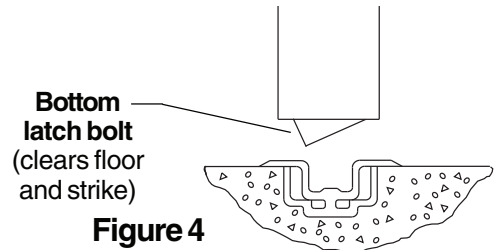

12. Turn bottom locking screw in. Do not over-tighten.
13. Check device operation by opening and closing door several times from the outside.

Redo adjustment procedure if :

- Top latchbolt is not held retracted
- Bottom latchbolt does not clear floor and bottom strike

FRAME PREPARATION

TOP STRIKE

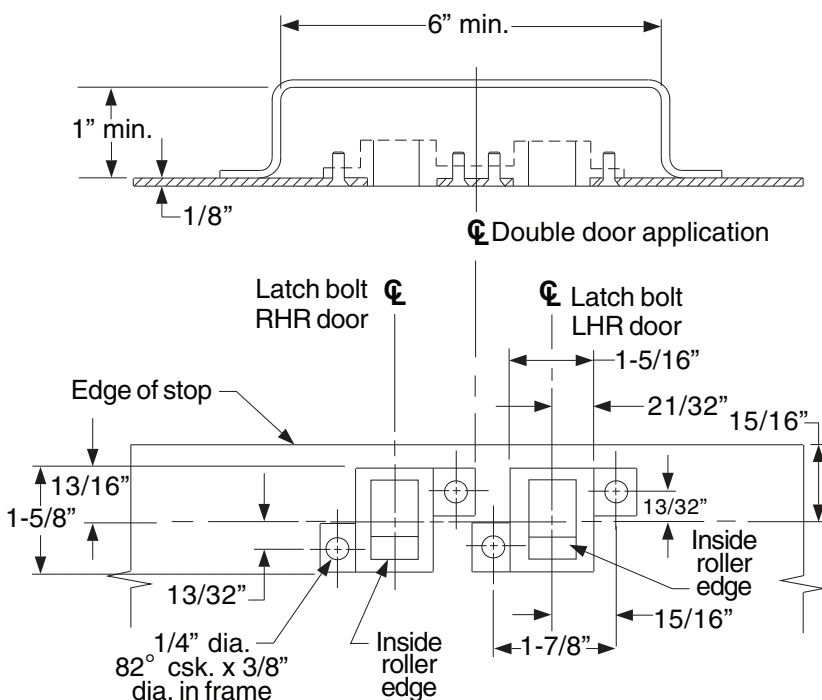

RATCHET RELEASE

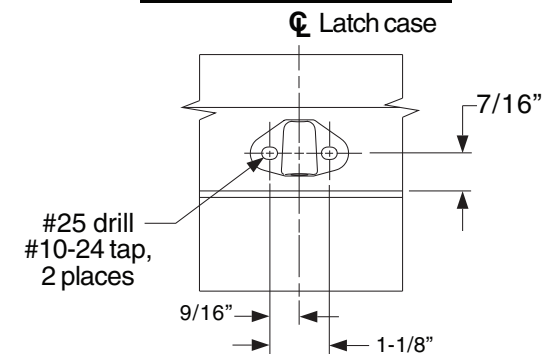

DO NOT USE SLOTS FOR POSITIONING. DRILL HOLES AS INDICATED HERE.

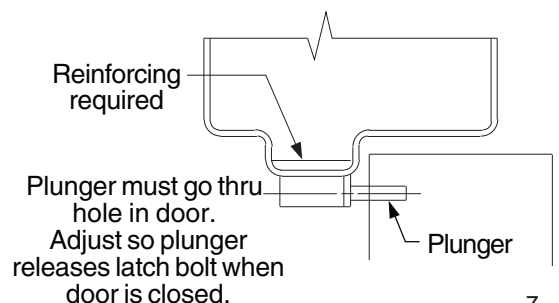

OPTIONAL EQUIPMENT - CONTINUED

CD (CYLINDER DOGGING)

1. Remove mortise cylinder cam and reinstall in reverse (Figure 6).
2. Insert key and rotate cam to install the cylinder to the cover plate (Figure 7).
3. Remove key to slide cover plate in position in the mechanism case.

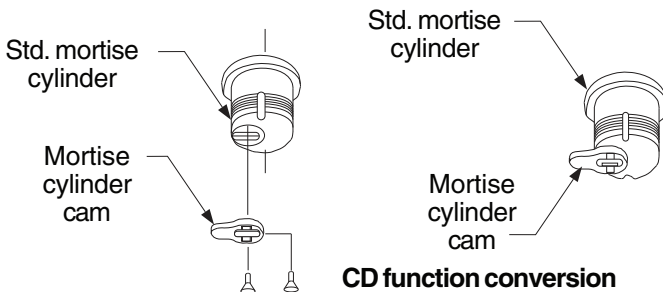

Figure 6

Dogging procedure

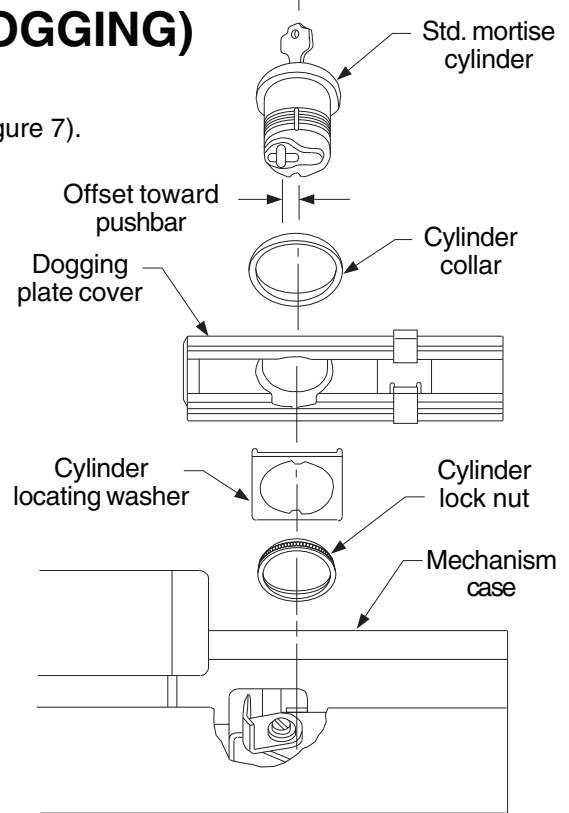
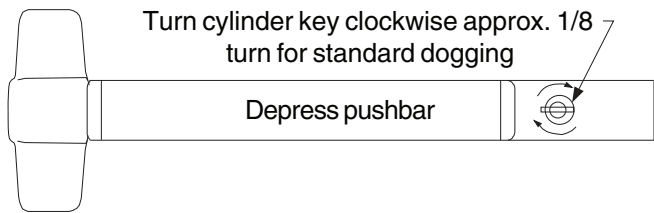
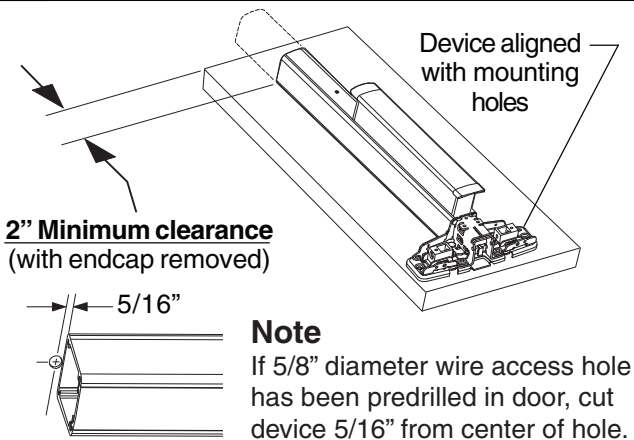

Figure 7

CUT DEVICE

1 Measure amount to cut off device.



2 Tape and mark area being cut.

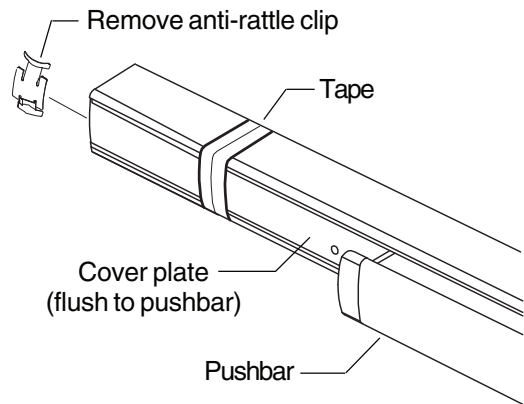

3 Cut device square.

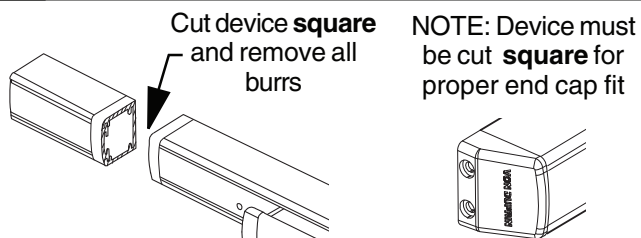

4 Slide anti-rattle clip into device.

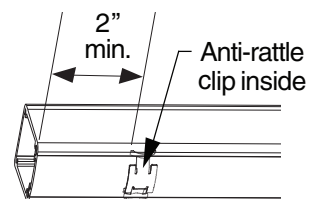

ADDITIONAL INSTALLATION REQUIREMENTS

- Before installation ensure door and frame are in good condition, correctly hung and not distorted
Note - Maximum door distortion of 5mm to ensure safe exit.
- It is not recommended that exit devices be fitted to hollow core doors unless specially designed for this type of door.
- It is recommended to verify that the door construction allows the use of the device, i.e. to verify that offset hinges and engaging leaves allow both leaves to be opened simultaneously, or to verify that the gap between door leaves does not differ from that defined by the exit device producer, or to verify that the opening elements do not interfere, etc.
- Before fitting an emergency exit device to a fire/smoke resisting door, the fire certification of the fire door assembly on which the exit device has been tested to prove suitability for use on a fire door should be examined. It is of utmost importance that an exit device is not used on a fire door assembly of a greater fire resistance time than approved for.
- Care should be taken to ensure that any seals or weather-stripping fitted to the complete door assembly does not inhibit the correct operation of the emergency exit device.
- On double door sets with rebated meeting stiles and where both leaves are fitted with emergency exit devices, it is essential to check that either leaf will open when its emergency exit device is activated and also that both leaves will open freely when both emergency exit devices are operated simultaneously.
- Category 2 (Standard projection) emergency exit devices should be used in situations where there is restricted width for escape, or where the doors to be fitted with the emergency exit devices are not able to open beyond 90°
- Different fixing can be necessary for fitting emergency exit devices to wood, metal or frameless glass doors. For more secure fixing, male and female through-door bolts, reinforcement and rivets can be used.
- These exit devices are not intended for use on double action (double swing) doors.
- These fixing instructions should be carefully followed during installation. These instructions and any maintenance instructions should be passed on by the installer to the user.
- When installing lever operating emergency exit devices, particularly on doors with raised or recessed surfaces, consideration should be given to minimizing any potential safety risks, such as the trapping of fingers or clothing.
- The bolt heads and keepers should be fitted to provide secure engagement. Care should be taken to ensure that no projection of the bolt heads, when in the withdrawn position, can prevent the door swinging freely.
- Where emergency exit devices are to be fitted to double doorsets with rebated meeting stiles and self closing devices, a door coordinator device in accordance with EN 1158 should be fitted to ensure the correct closing sequence of the doors. This recommendation is particularly important with regard to smoke/fire-resisting door assemblies.
- No devices for securing the door in the closed position should be fitted other than specified in EN 1125 / EN 179. This does not preclude the installation of self-closing devices.
- If a door closing device is to be used to return the door to the closed position, care should be taken not to impair the use of the doorway by the young, elderly and infirm.
- Where applicable, the "Push to open" sign should be applied on the inside face of the door immediately above the operating element.

MAINTENANCE INSTRUCTIONS

To ensure performance in accordance with the relevant standard, the following routine maintenance checks should be undertaken at intervals of not more than one month.

- a) Inspect and operate the emergency exit device to ensure that all components are in a satisfactory working condition.
Using a force gauge, measure and record the operating forces to release the exit device.
- b) Ensure that the keepers are clean and free from obstruction
- c) Check that the emergency exit device is lubricated if required.
- d) Check that no additional locking devices have been added to the door since its original installation.
- e) Check periodically that all components of the system are still correct in accordance with the list of approved components originally supplied with the system.
- f) Check periodically that the operating element is correctly tightened and, using a force gauge, measure the operating forces to release the exit device.
Check that the operating forces have not changed significantly from the operating forces recorded when originally installed.
- g) Check that all fixing screws are tight.

These instructions should be passed on by the installer to the user on completion of installation.

PRODUCT INFORMATION

- To comply with EN1125 : 2008 door leaf must not exceed 2500mm high x 1300mm wide x 200Kg maximum weight.
- This product is intended for use on single and / or double leaf outward opening fire escape route doors.
- Category of projection : Category 2
- Field of door application : Category A
- Resistance of door leaf against pulling force of the recommended fixing screws: 1000N maximum achieved.

CERTIFICATION DETAILS

	<p>ALLEGION </p> <p>35 Rocky Lane, Aston Birmingham, B6 5RQ, United Kingdom</p>										
<p>2812-CPR-AAA5007</p>	<p>2021</p>										
<p>EN 1125:2008</p>	<table border="1"> <tr> <td>3</td> <td>7</td> <td>6</td> <td>0</td> <td>1</td> <td>3</td> <td>2</td> <td>2</td> <td>B</td> <td>A</td> </tr> </table>	3	7	6	0	1	3	2	2	B	A
3	7	6	0	1	3	2	2	B	A		
	<p>2812-CPR-AAA7571</p> <p>2021</p>										

