



23884539

Magnetic Card Reader

Models SMR-10 and SMR-20
Installation and Maintenance Instructions



Contents

General.....	1	Maintenance.....	3
Mounting the Reader.....	1	DIP switch/Jumper setting.....	4
Reader Wiring.....	1	SMR10/20 Standard Format Code Summary.....	5
Connecting the Keypad.....	2	Specification.....	6
Weather-Proofing the Reader.....	2	Product Identification.....	6
TTL Interface.....	2	Reader Mounting Dimensions.....	7
Grounding the Reader.....	3	Warranty.....	8
Keypad Data and Tamper Monitor Signalling.....	3	Liability.....	8
Reader Verification.....	3		

General

The SMR10/20 family of magnetic stripe card readers are designed for reading standard or high-coercivity magnetic stripe cards. The SMR20 also provides a 12-key keypad for PIN entry. The SMR10/20 provides a TTL interface. The following paragraphs describe instructions for installing and maintaining the card reader.

Mounting the Reader

Find a suitable location to anchor the reader mounting bracket. The reader may be mounted vertically or horizontally. See recommended orientation. The mounting of the reader does not require a junction box. However, rigid conduit is required for outdoor application. A single gang junction box may be used to provide a transition to rigid conduit. If a single gang junction box is used, a wall plate (optional) may be used to cover the junction box. The reader is then secured to the mounting bracket using a screw. Refer to figures for reader dimensions and typical junction box usage.

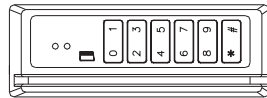
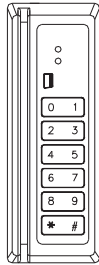

Recommended



Not Recommended

Reader Wiring

The reader has a RJ-11 modular jack for easy field connection. A small piece of pre-terminated cable is supplied with each standard reader for field wiring. The pre-terminated cable has nonstandard color. Refer to pin number if the pre-terminated cable is not used. Cable with wires of 24AWG or larger are recommended for field wiring.



www.schlage.com



(877) 671-7011

Connecting the Keypad

The SMR20 reader provides a 12-key keypad for PIN entry. The flex tail of the keypad is connected to the electronic board via a ZIF (zero insertion force) connector. The contacts are engaged/disengaged by a moving slide. Care must be exercised when connecting and disconnecting the keypad. When connecting the keypad to the board, open the slide as shown. Insert the electronics into the housing and insert flex tail in the ZIF connector. Then, close the slide to engage the contacts. To disconnect the keypad, follow the previously described steps in reverse.

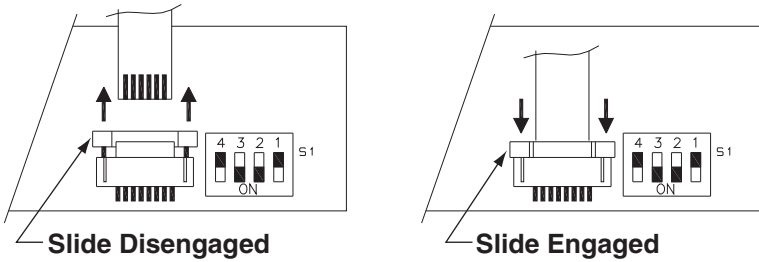

CAUTION: DO NOT DISCONNECT KEYPAD WITHOUT DISENGAGING THE CONNECTOR!

Weather-Proofing the Reader

The reader is rated to operate over an extended temperature range. However, if the reader is expected to be exposed to weather, the weatherized option (-OW) must be ordered. The option is implemented in two parts. With the (-OW) option, the electronics is conformal coated against moisture. A tube of dielectric grease is supplied for the installer to coat field connections to complete the procedure. After field connection/configuration is made, the grease is to be applied on the DIP switch slides, keypad connection, and the RJ-11 jack to seal out moisture.

→ **Do not use sealant to seal reader case to the wall. Doing so will trap water in the reader and may cause damage to the reader.**

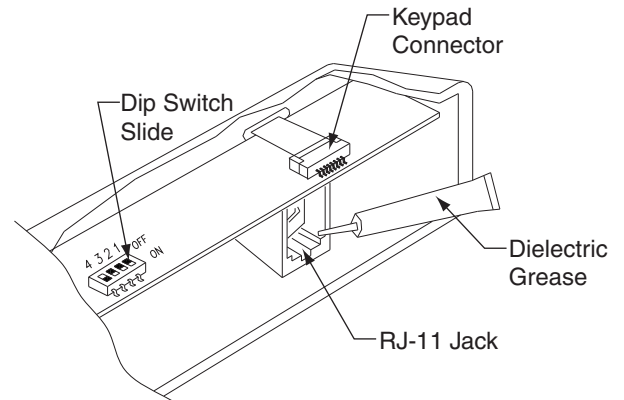

TTL Interface

The TTL interface has the standard 5-wire interface widely used in the access control application. In addition, an input to control the buzzer is provided. Cable with minimum of 24AWG wires should be used.

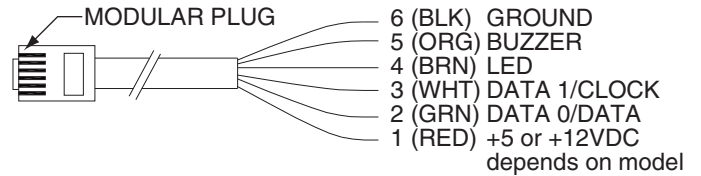

Pin #	Wire	Signal	Description
1	Red	Vin	Power supply input, 5Vdc or 12Vdc, Model dependent
2	Green	/Data (Mag) or /Data 0 (Wieg)	Reader data output
3	White	/Clock (Mag) or /Data 1 (Wieg)	Reader data output
4	Brown	LED	LED input: 1-wire control: 0V turns on the green LED 5V turns on the red LED 2-wire control: 0V turns on the red LED
5	Orange	Buzzer/LED	Buzzer/LED input: 1-wire control: 0V turns on the buzzer 2-wire control: 0V turns on the green LED
6	Black	Signal Ground	Power supply return, DC ground

Highlighted states are compatible with the CT5000 or the WRI.

Grounding the Reader

To avoid having ESD (electrostatic discharge) interfering with the operation of the reader, the reader casing shall be grounded. This can be accomplished by tying the mounting bracket to earth ground locally (e.g. grounded conduit).

DIP Switch/Jumper Setting

The DIP switch/jumper on the SMR10/20 readers are used to select a preset format. This preset format determines how the card is interpreted, the functions for the LED and buzzer, and the output signal format, etc. Refer to the format specification for detail. The settings are for STANDARD models ONLY.

Format	Switch				Output	LED	Buzzer	Tamper
	4	3	2	1				
0	on	on	on	on	DATA1/DATA 0	1-WIRE	yes	no
1	on	on	on	off	CLOCK/DATA	1-WIRE	yes	no
2	on	on	off	on	CLOCK/DATA	1-WIRE	yes	yes
3	on	on	off	off	CLOCK/DATA	1-WIRE	yes	no
4	on	off	on	on	DATA 1/DATA 0	1-WIRE	yes	no
5	on	off	on	off	DATA 1/DATA 0	1-WIRE	yes	no
6	on	off	off	on	DATA 1/DATA 0	1-WIRE	yes	no
7	on	off	off	off	DATA 1/DATA 0	1-WIRE	yes	no
12	off	off	on	on	CLOCK/DATA	2-WIRE	no	no
13	off	off	on	off	DATA 1/DATA 0	2-WIRE	no	no
15	off	off	off	off	CLOCK/DATA	1-WIRE	yes	yes

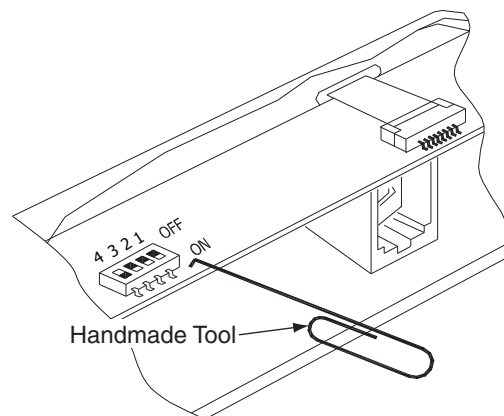

Highlighted states are compatible with the CT5000 or the WRI.

SMR10/20 Standard Format Code Summary

The following formats are supported in standard models (300x2-0000/310x2-0000). Unless otherwise indicated, the LED input line controls both LEDs (low=green, high=red); the BUZZER input controls the buzzer (low = activate); a good read is signaled by a flash of the green LED; a bad read is signaled by a flash of the red LED and a double beep of the buzzer.

Format	Description
0	32-bit Wiegand compatible output from standard Northern Computer mag card. 16-bit facility code and 16-bit user ID. Reverse read and error filter is enabled. Tamper monitor disabled.
1	Basic mag-stripe data output: send track 2 data without any verification or formatting using CLOCK/DATA signaling. (All reads are "good", card data is sent as is.) Tamper monitor disabled.
2	Mag-stripe data output with zero trim using CLOCK/DATA signaling. (All reads are "good", trims excess zero bits, otherwise sends data as is.) Tamper monitor enabled.
3	Mag-stripe data output with zero trim, reverse read correction, and error filter enabled using CLOCK/DATA signaling. Tamper monitor disabled.
4	26-bit Wiegand (8-bit fac. and 16-bit ID) compatible output from cards with 8 or more digits or AMC encoding. See Digit Usage on page 3 for more information. Tamper monitor disabled.
5	34-bit Wiegand (12-bit fac. and 20-bit ID) compatible output from cards with 8 or more digits or AMC encoding. See Digit Usage on page 3 for more information. Tamper monitor disabled.

Format	Description
6	26-bit Wiegand compatible output from standard Northern Computer 32-bit mag-stripe card. The lower 8 bits of the 16-bit facility code is used as facility code. The 16-bit user ID is unaltered. Reverse read and error filter is enabled. Tamper monitor disabled.
7	Mag-stripe data output with zero trim and reverse read correction using DATA 1/DATA 0 signaling. Tamper monitor disabled.
12	Mag-stripe data output using CLOCK/DATA signaling. 2-wire LED control. No buzzer control. Tamper monitor disabled.
13	Mag-stripe data output using DATA 1/DATA 0 signaling. 2-wire LED control. No buzzer control. Tamper monitor disabled.
15	(factory test) mag-stripe data output: verify track 2 data and send track 2 data without formatting using CLOCK/DATA signaling. Zero trim, reverse read, bad card filter, and tamper monitor option are enabled.

Digit Usage

Digits in mag card	Facility Code			User ID		
	Digits	26-bit Range	34-bit Range	Digits	26-bit Range	34-bit Range
8	1-3	000-255	000-999	4-8	00000-65535	00000-99999
9	1-3	000-255	000-999	4-9	000000-065535	000000-999999
10	1-4	0000-0255	0000-4097	5-10	000000-065535	000000-999999
11 or more	1-5	00000-00255	00000-04097	6-11	000000-065535	000000-999999
AMC card	1-6	000000-000255	000000-004097	7-12	000000-065535	000000-999999

Keypad Data and Tamper Monitor Signalling

Keypad data and tamper monitor status are transmitted on the data lines as 8-bit blocks. They are encoded and sent using the same signaling method as selected for the card data output (clock/data or data 1/data 0). If Dorado 8-bit keypad data format is required order the -K1 option. Card data, tamper status data, and keypad data blocks are separated by a minimum of 100 milliseconds. See following for codes:

10110000 - 0 (ASCII '0', odd parity, MSB first)	00110001 - 1 (ASCII '1', ...)
00110010 - 2 (ASCII '2', ...)	10110011 - 3 (ASCII '3', ...)
00110100 - 4 (ASCII '4', ...)	10110101 - 5 (ASCII '5', ...)
10110110 - 6 (ASCII '6', ...)	00110111 - 7 (ASCII '7', ...)
00111000 - 8 (ASCII '8', ...)	10111001 - 9 (ASCII '9', ...)
00101010 - * (ASCII '*', ...)	00100011 - # (ASCII '#', ...)
11010011 - SAFE (ASCII 'S', ...)	01010100 - ALARM (ASCII 'T', ...)

Highlighted states are compatible with the CT5000 or the WRI.

Reader Verification

The reader performs a self-test when power is first applied to the unit. If power-on test is successfully completed, The reader will turn on both LEDs for approximately 1 second and sound the buzzer for 1 short beep. Then the reader is ready for normal operation.

If further verification of the reader hardware is needed, the reader may be temporarily set to format T. With this format selected, the reader will read and verify standard ANSI track 2 encoded card. If no read error is detected, the green LED will flash. Otherwise, the red LED will flash and the buzzer will sound two short beeps to indicate an error. The LED input can be used to verify the LED function; and the buzzer input for the buzzer function. For the SMR20, the reader will echo a key press with a brief flash of both LEDs and a short beep of the buzzer. Reset to the required format for normal operation after test.

Maintenance

The readers are designed to provide continuous service with minimal routine maintenance. However, contaminants (such as magnetic oxides from badges and dirt) tend to accumulate on the read head. Without regular cleaning, these contaminants will shorten the read head life and increase the probability of card read error. A maintenance schedule should be developed base on the card reader environment (dirty or clean) and the usage frequency (light traffic or heavy traffic). Extreme case may require daily cleaning.

Head cleaning may be done by using a disposable, pre-saturated magnetic head cleaning card. These cards are readily obtainable from a number of sources (e.g. Clean Team Co., www.cleanteam.com, 800-888-8830; KIC Products, www.kicproducts.com, 207-514-7030; System ID, www.systemid.com 888-648-4452).

The reader exterior surface is covered with high strength polymer and polyester membrane. It may be cleaned with a soft cloth and mild detergent if required.

The reader is for use in low voltage, class 2 circuits only.

Specification

The reader is for use in low voltage, class 2 circuits only.

Power	Voltage	5Volt Model: 5.8 Vdc (4.9 to 6.4 Vdc) 12Volt Model: 12 Vdc (10.2 to 13.8 Vdc)	
	Current	50mA (25mA typical.)	
Data output	Data 1/0 pair or clock/data		
	Timing	clock/data	period 1mS setup/hold time 400uS, clock pulse width 200uS typical
data 1/0		period, 1mS for Wiegand data, 1mS for mag stripe data pulse width 50uS typical	
LED input	1-wire mode	input not driven: LEDs off input > 3.5Vdc: Red LED on input < 0.8Vdc: Green LED on	
	2-wire mode	input < 0.8Vdc: Red LED on	
Buzzer/LED	1-wire mode	input not driven or > 3.5Vdc: buzzer off input < 0.8Vdc: buzzer on	
	2-wire mode	input < 0.8Vdc: Green LED on	
Mechanical	Dimension	1.95" (50mm) W x 1.30" (33mm) H x 5.50" (140mm) L	
	Weight	10 oz. (284 g) nominal	
	Material	Case, Die cast aluminum, gray powder coat standard. Mounting, stainless steel Wall plate, 18 CRS, gray powder coat standard	
Car	75 bpi, ANSI X4.16, Track 2 standard, Speed 3 to 50 ips		
Read Head	1,000,000 passes typical, standard.		
Distance	500' (152m) with 18 AWG wires.		
Environmental	Temperature	-55 to +85 degrees C, storage -40 to +75 degrees C, operating	
	Humidity	0-95% RHNC, standard 100% (-OW option)	

Highlighted states are compatible with the CT5000 or the WRI.

Product Identification

Reader product identification is provided on labels. These labels have information on program ID, revision, product ID, supply voltage, and copyright notice. These labels are located on the circuit board and the back of the reader.

10218	←	Program ID
SN 00100	←	Serial No.
MSC (c)'93	←	Copyright

PN: 30012-0000	Model: MR-10-OW	 OUTDOOR USE ACCESS CONTROL UNIT ACCESSORY LISTED
SN: 00100	DATE: 9502	
RATED: 12Vdc 80mA		6T32 BP6565
FOR INSTRUCTION, SEE: 10107-0000		
REV: 3/05	MADE IN USA	

↑ Manual revision, see appropriate manual for FORMAT information

Reader Mounting Dimensions

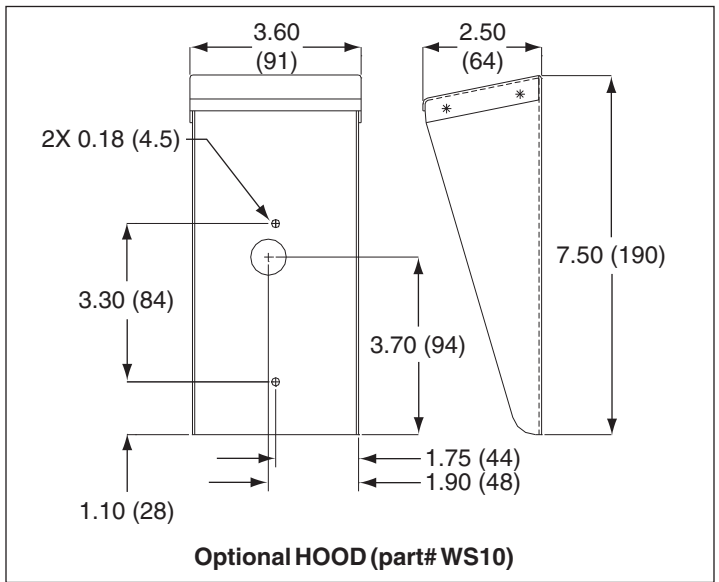
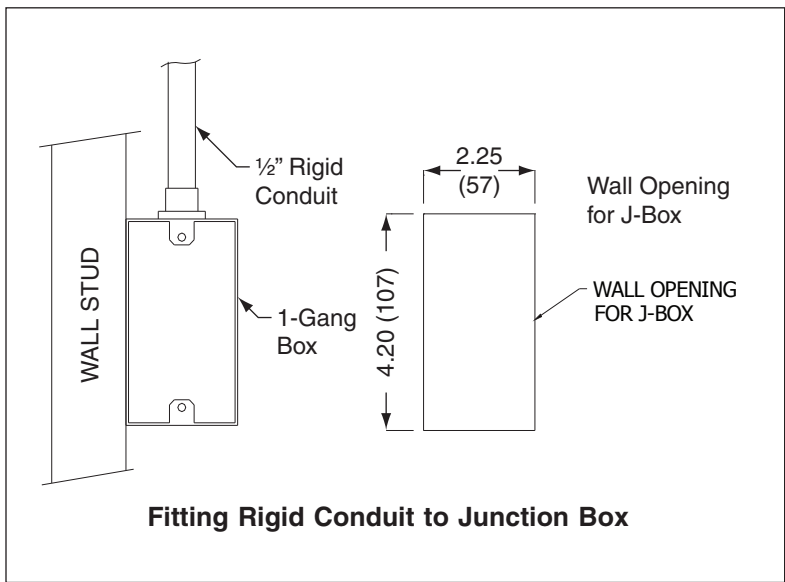
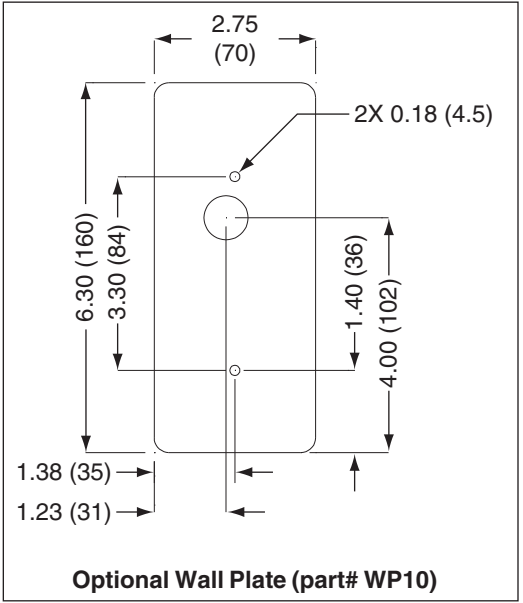
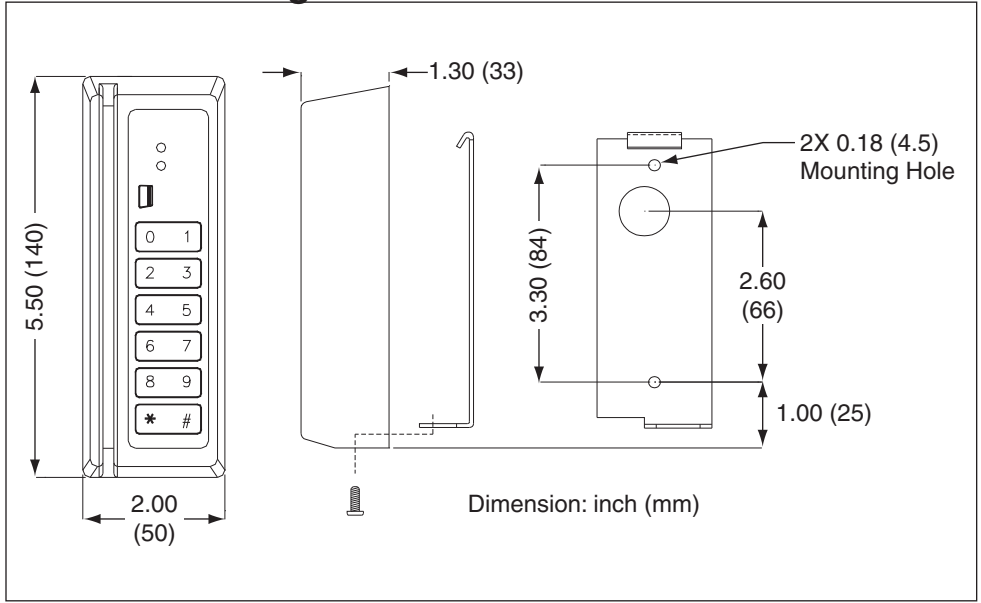

Warranty

Schlage Lock Company warrants the product is free from defects in material and workmanship under normal use and service with proper maintenance for two years from the date of factory shipment. Schlage Lock Company assumes no responsibility for products damaged by improper handling or installation. This warranty is limited to the repair or replacement of the defective unit.

There are no expressed warranties other than set forth herein. Schlage Lock Company does not make, nor intends, nor does it authorize any agent or representative to make any other warranties, or implied warranties, and expressly excludes and disclaims all implied warranties of merchantability or fitness for a particular purpose.

Returned units are repaired or replaced from a stock of reconditioned units. Returns must be accompanied by a return authorization number (RMA) obtained from customer service, and prepaid postage and insurance.

Liability

The card readers should only be used to control exits from areas where an alternative method for exit is available. This product is not intended for, nor is rated for operation in life-critical control applications. Schlage Lock Company is not liable under any circumstances for loss or damage caused by or partially caused by the misapplication or malfunction of the product. Schlage Lock Company's liability does not extend beyond the purchase price of the product.

