



941093-00

388NL

VON DUPRIN®

Cylinder Control

Installation Instructions

1 Prepare door for exit device.	To Adjust Tailpiece Length
See exit device instructions for locations of holes, backset (line X-X) and center lines.	Cut cylinder tailpiece as shown.
2 Prepare door for control:	
2a Transfer line X-X from inside (exit device) side of door to outside (control side) of door. Use extra care if edge of door is beveled. Be sure line X-X is parallel to edge of door.	
2b Locate and prepare holes as shown on other side.	
3 Prepare control:	
3a Orient control as shown for your application (RHR or LHR) and make sure mounting studs are in positions shown. If not, move mounting studs to correct positions.	
3b Install cylinder.	
3c If necessary, adjust tailpiece length.	
4 Apply exit device and control.	

CONTROL AND MOUNTING STUD POSITIONS

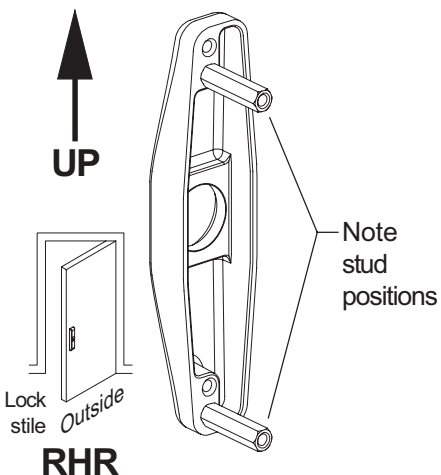
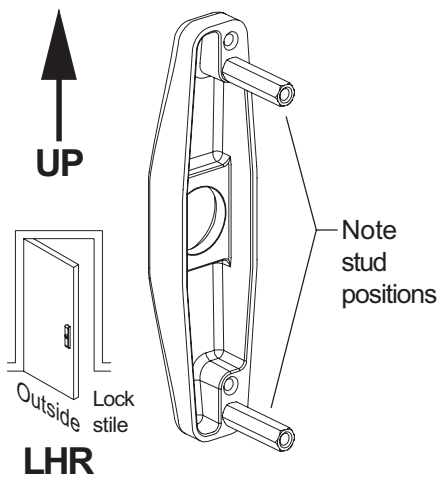

TO INSTALL CYLINDER

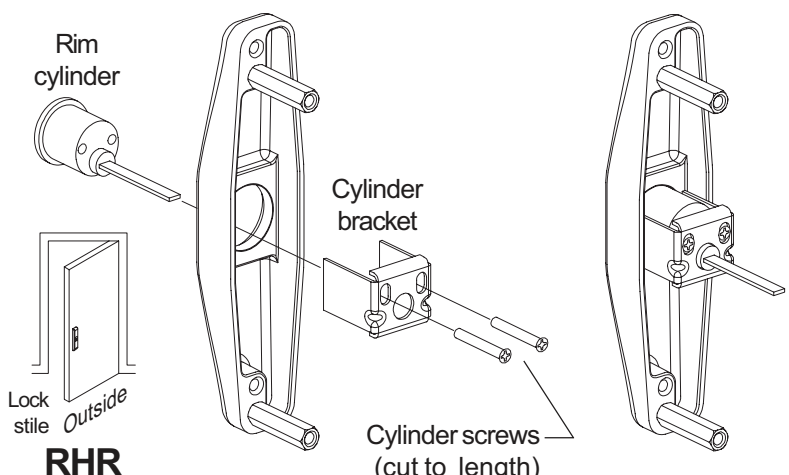
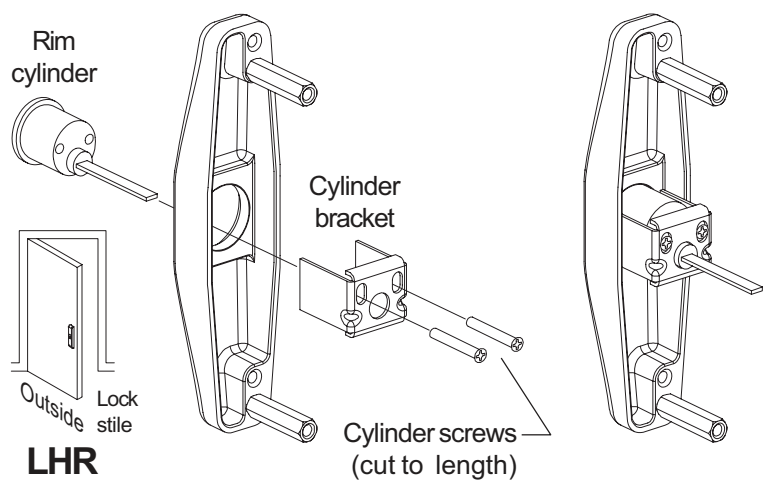

Door Preparation, Metal Door Application

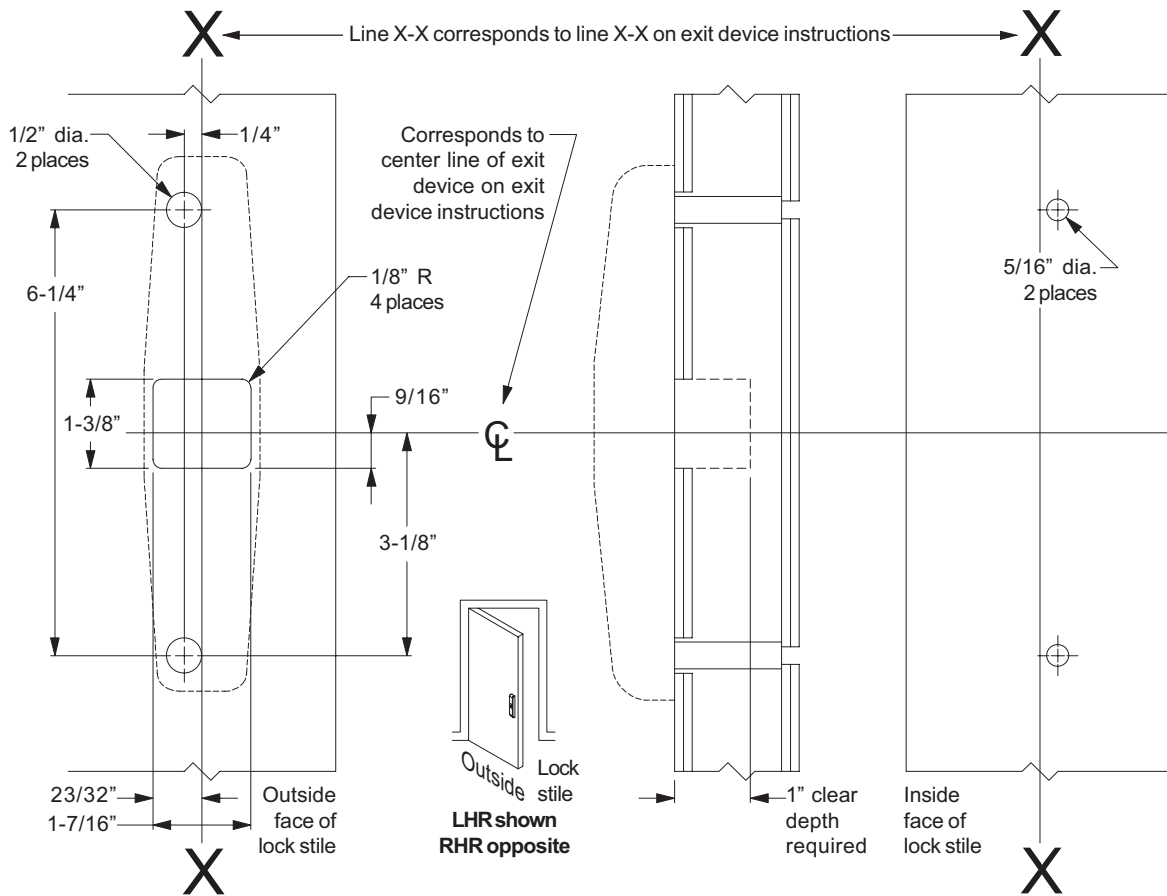

Door Preparation, Wood Door Application

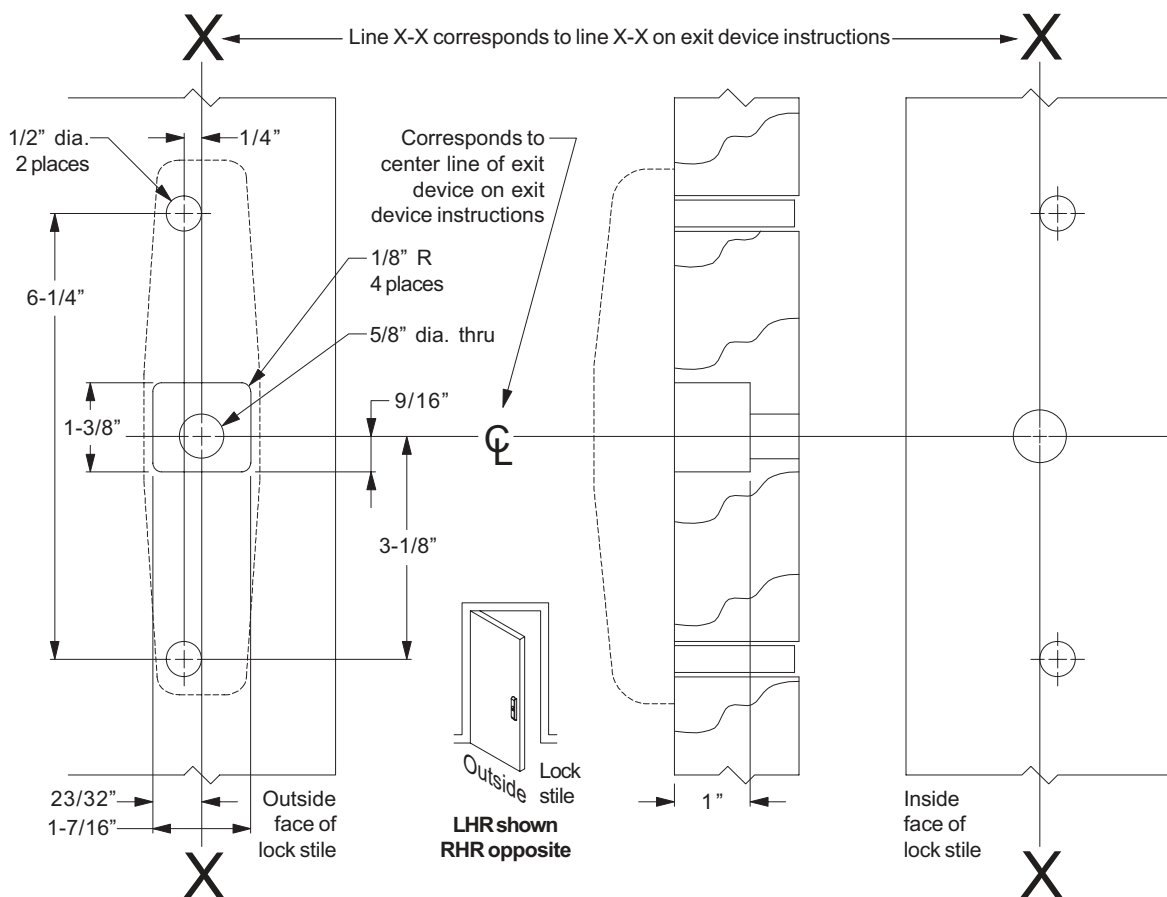

For cutouts on inside face of door, see exit device instructions.

Device Application Schedule
33A/35A Rim Device
3327A/3527A Vertical Rod Device
3347A/3547A Vertical Rod Device
3348A/3548A Vertical Rod Device
3327A-F/3527A-F Vertical Rod Device
3347A-F/3547A-F Vertical Rod Device
3348A-F/3548A-F Vertical Rod Device

Customer Service

1-877-671-7011

www.allegion.com



© Allegion 2014
Printed in U.S.A.
941093-00 Rev. 01/14-b