

# 1279 Strike

Wood Door, LHR Shown, RHR Opposite

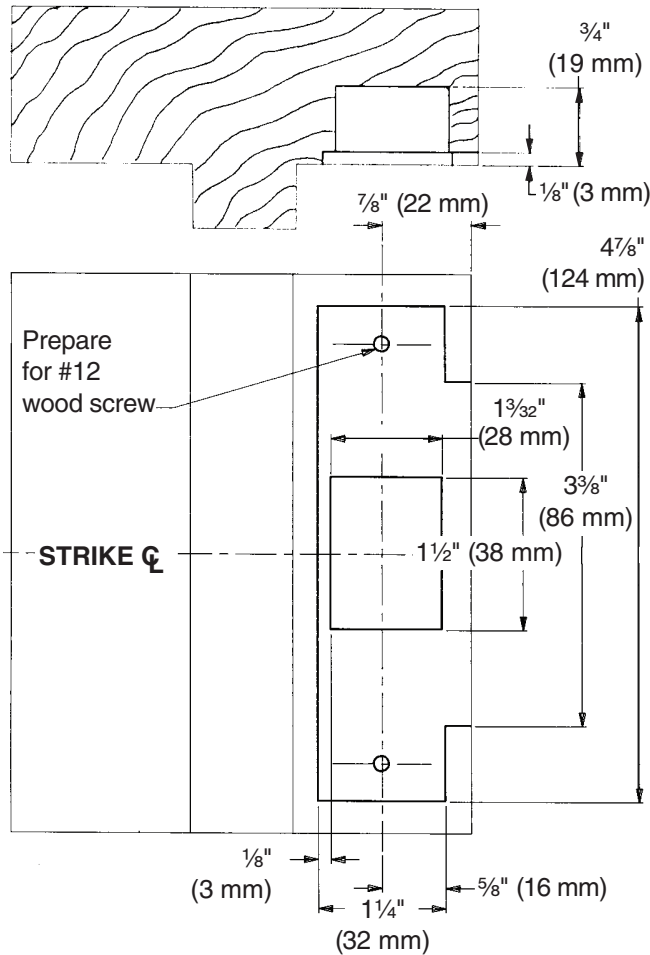

**WOOD FRAME PREPARATION**

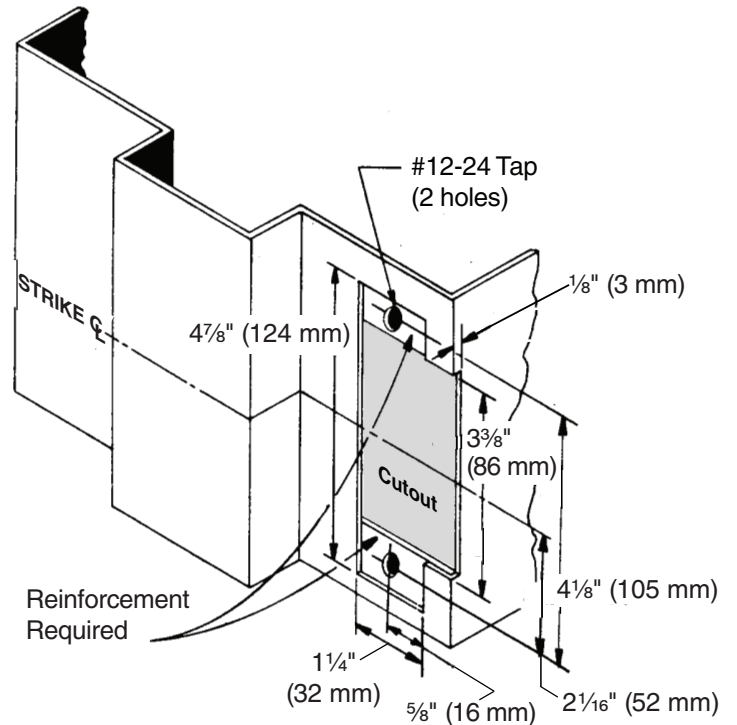

**METAL DOOR/FRAME PREPARATION**

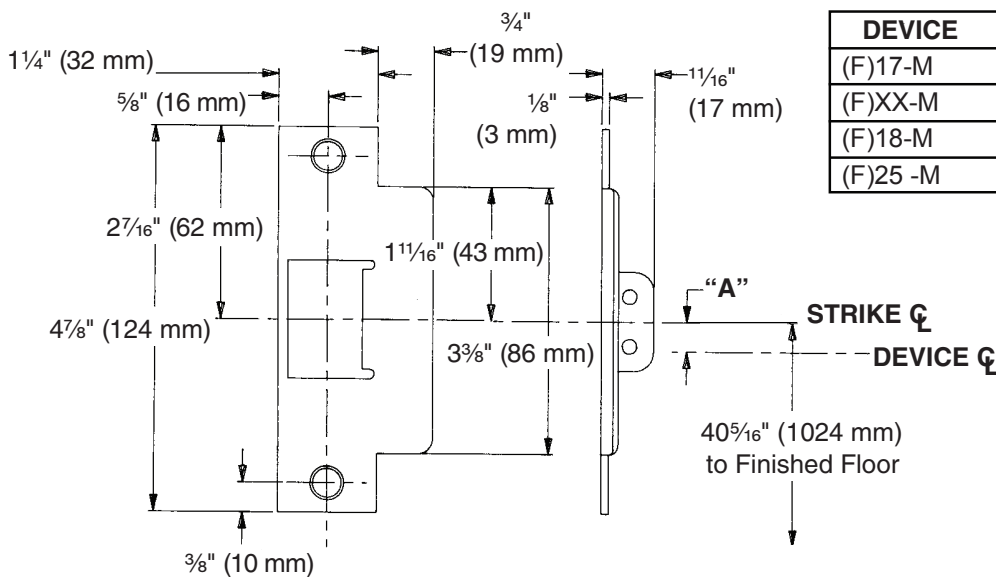

**STRIKE DETAIL**

DEVICE	"A"
(F)17-M	5/16" (8 mm)
(F)XX-M	1/16" (2 mm)
(F)18-M	1/16" (2 mm)
(F)25 -M	1/16" (2 mm)

TEMPLATE

**W-3015-b**

- For device function and other dimensions, see appropriate device or trim templates.