

1606 Strike

Wood Door, LHR shown, RHR opposite

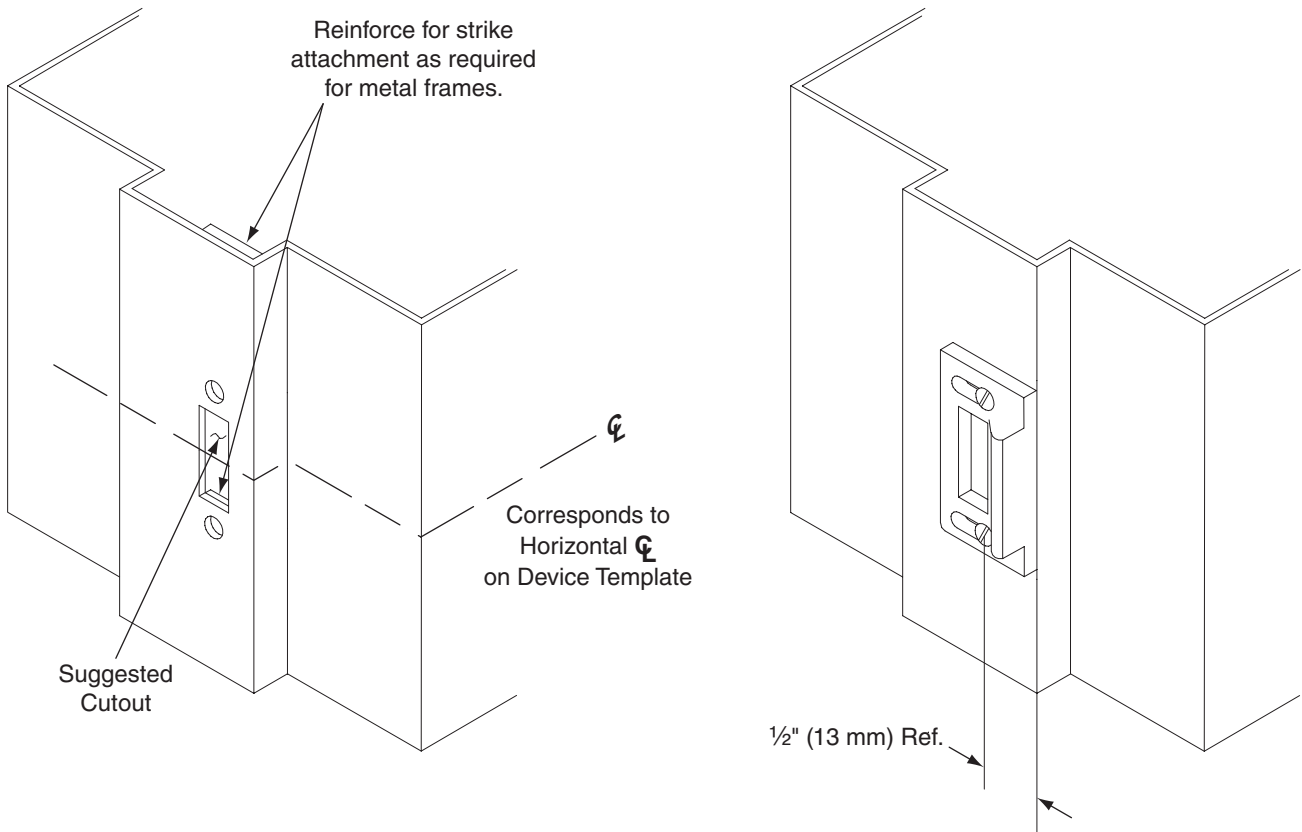

FOR METAL FRAME:
Drill and tap for #10-24 screws (2 holes)
FOR WOOD FRAME:
Drill $\frac{1}{8}$ " (3 mm) Dia. x 1" (25 mm) deep (2 holes)

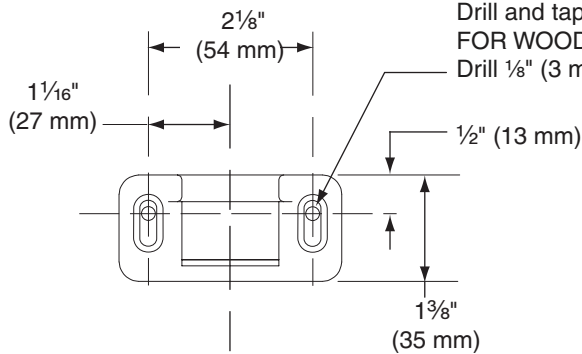

- For backset, refer to device template.
- For device function and other dimensions, refer to appropriate device or trim templates.
- Note: reinforcement required for metal frames.

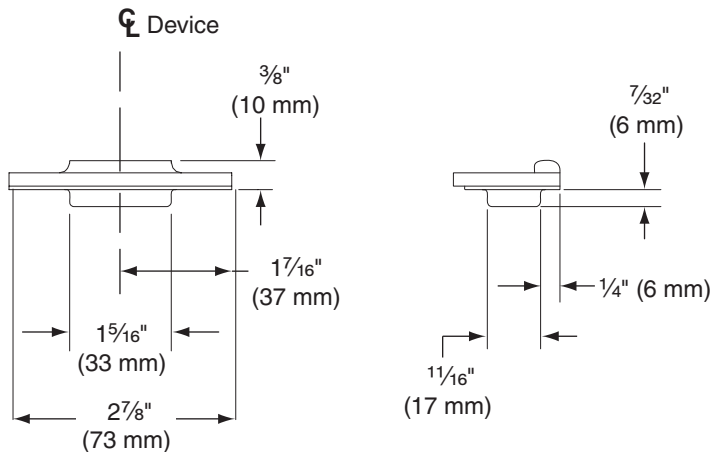

TEMPLATE
W-3205-a