

25-R Rim Device on ANSI A115.2 Prepared Door

Rim Panic Exit Device, Wood Door, LHR Shown, RHR Opposite

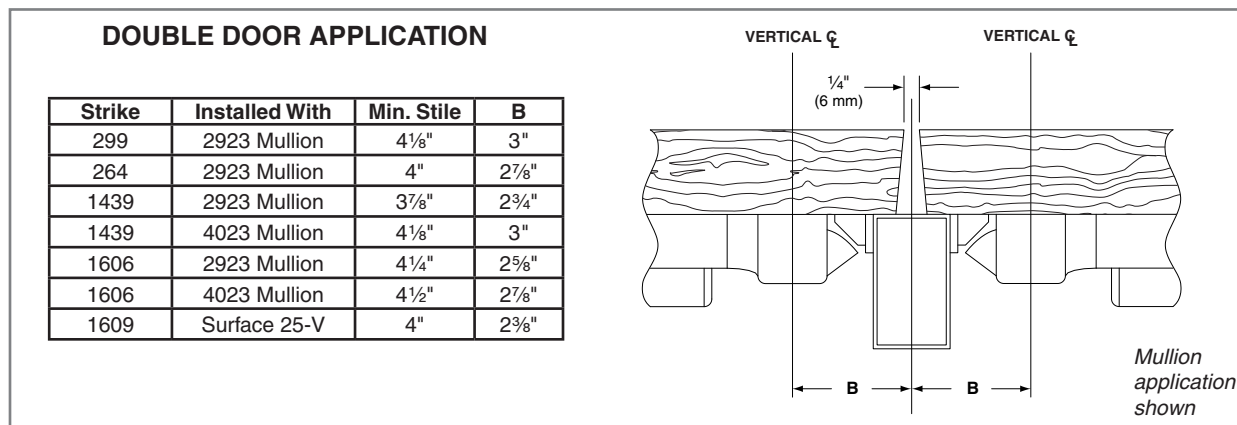
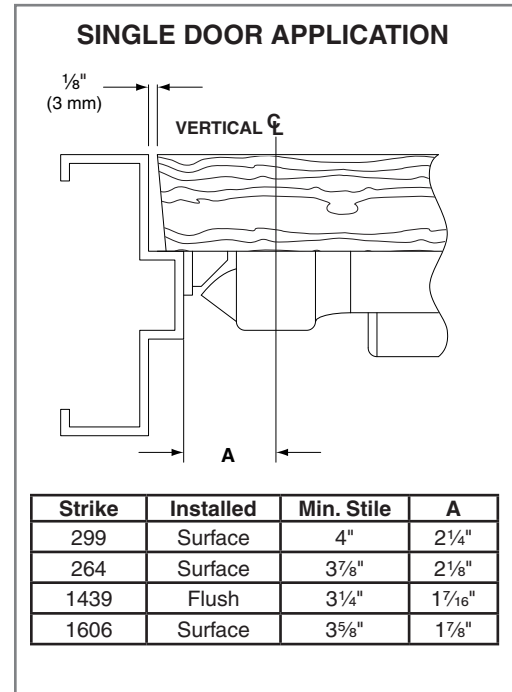
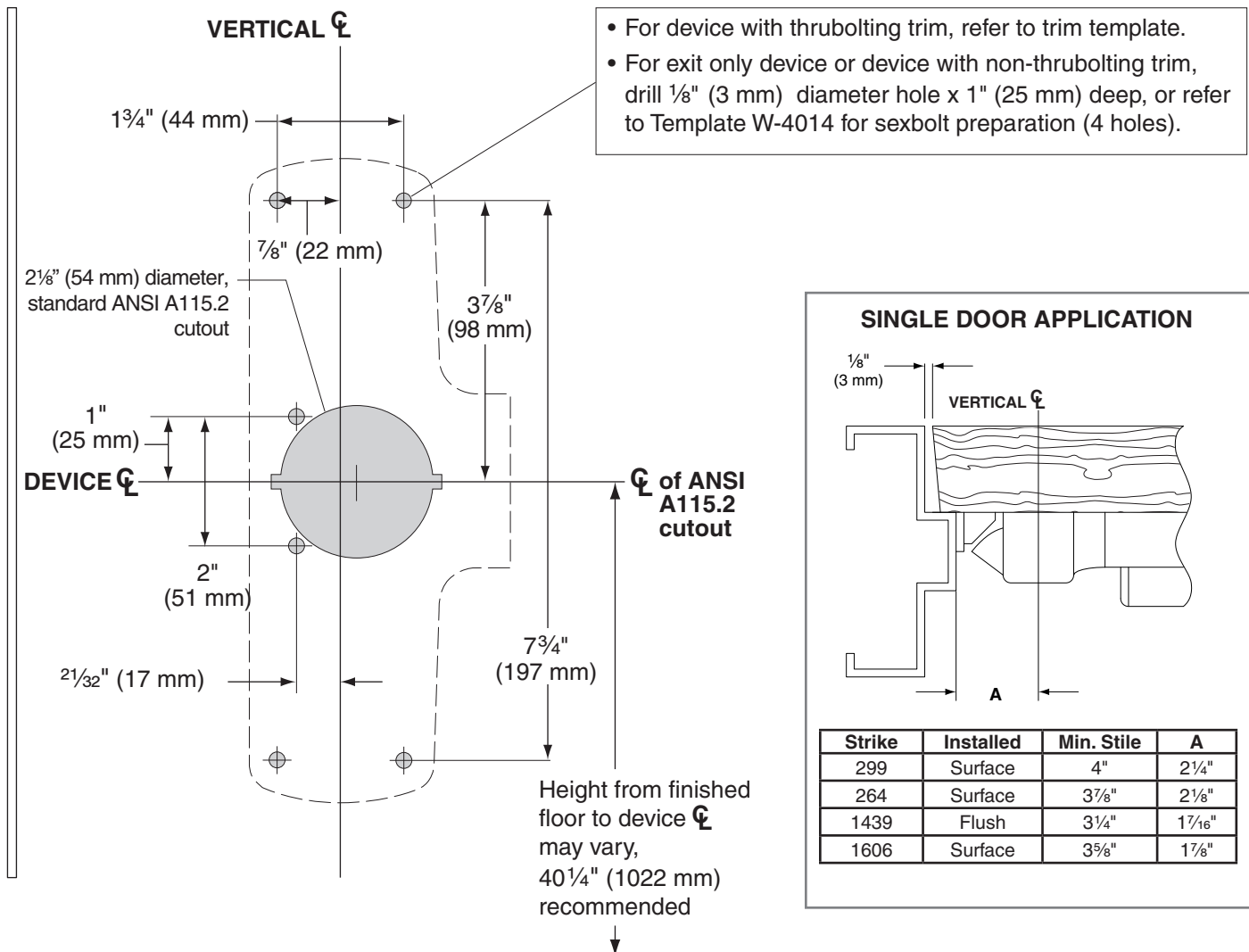

- On ANSI 115.2 door, vertical center line of device should be moved up or down to match vertical center line of ANSI 2 1/8" cutout
- ANSI A115.2 door cannot be used with NL-OP applications
- For sexbolt preparation, refer to Template W-4014.
- For outside trim, see trim template for door preparation.

**TEMPLATE
W-1260-a**