

579 Strike

Metal Door, LHR Shown, RHR Opposite

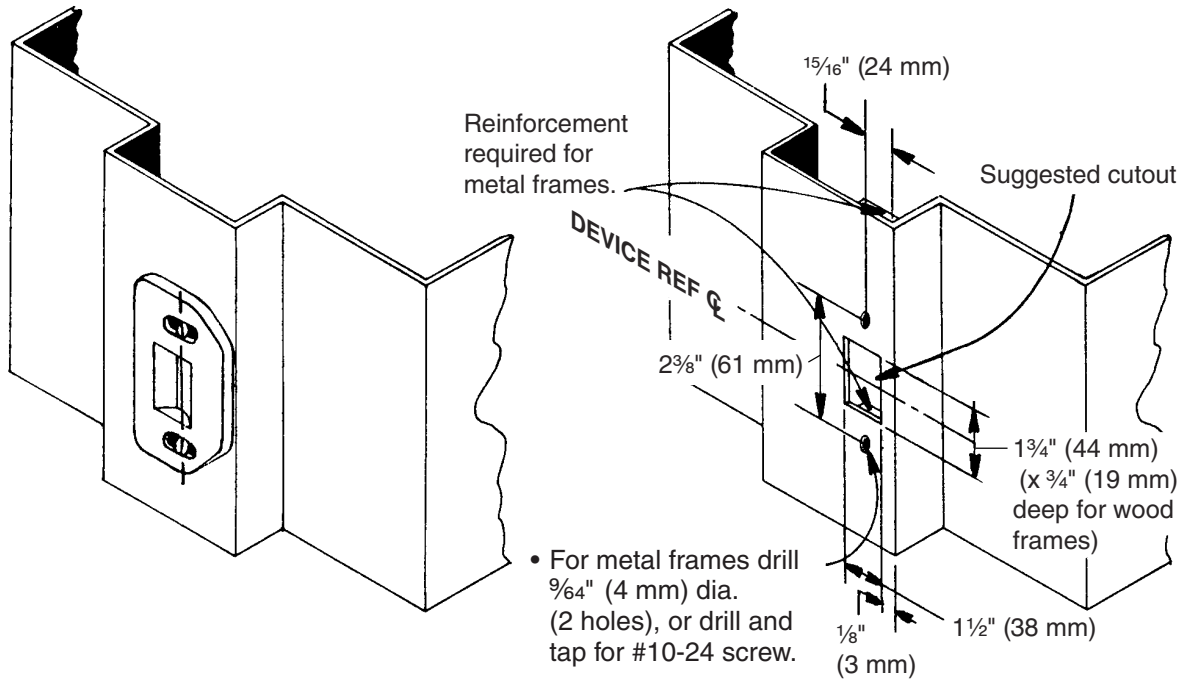

- For metal frames drill 9/64" (4 mm) dia. (2 holes), or drill and tap for #10-24 screw.
- For wood frames drill 9/64" (4 mm) dia. x 1 1/4" (32 mm) deep (2 holes).

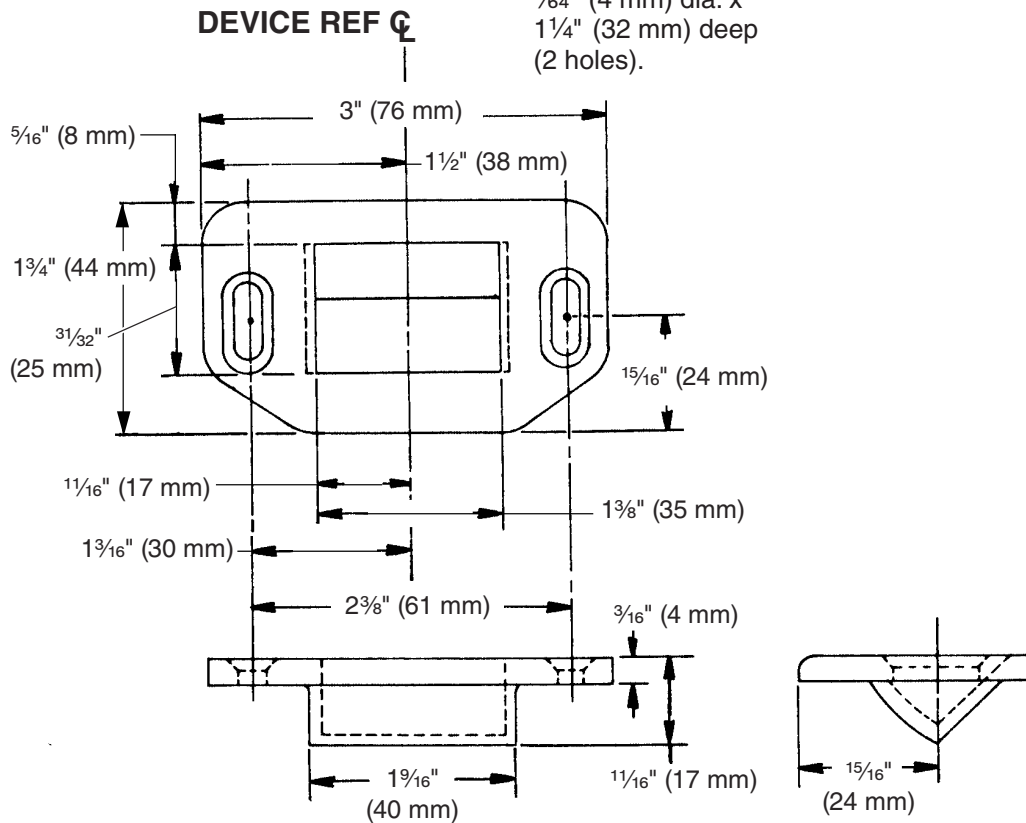

- For device function and other dimensions, see appropriate device or trim templates.

TEMPLATE
T-3005-a