



Strikes

Model 10-042

Jamb Type: Wood
 Style: Electric Latch Release
 Standard for:
 Optional for:

NOTE:

1. Provision must be made to route low voltage wire to latch release
2. Attach wires to the 6" (152) pigtails of the latch release
3. Pigtail leads located as shown for Right Hand swinging doors
4. For Left Hand swinging doors, leads are located at the top of latch release
5. Power transformer unit and low voltage wiring are not provided
6. All installations should be in accordance with local electrical codes

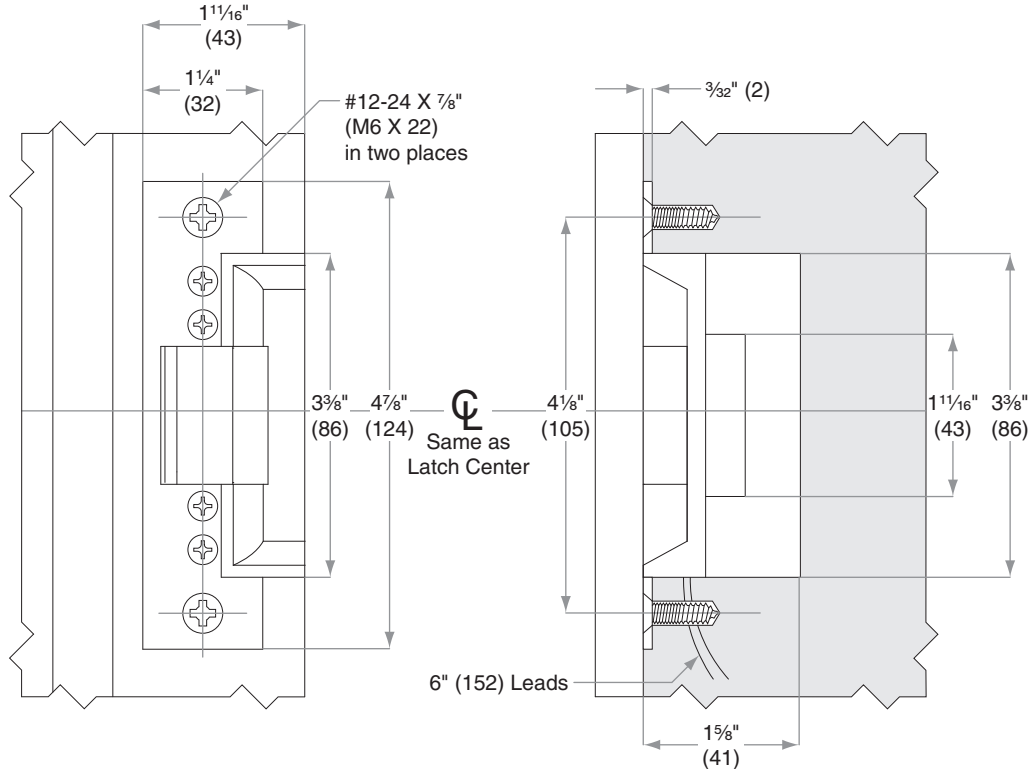
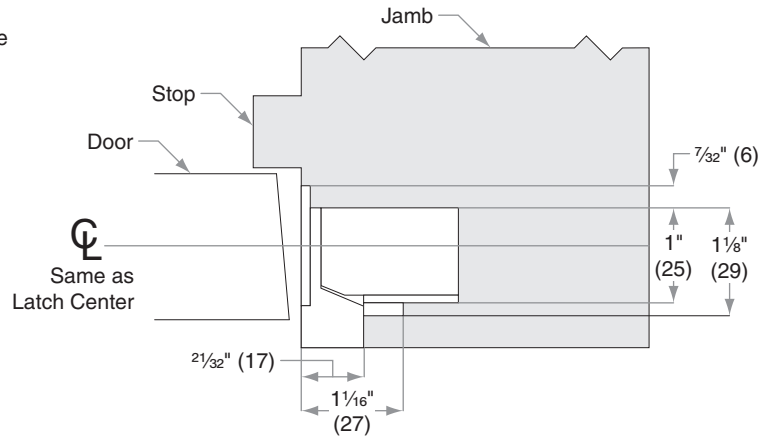

Dimensions shown in parentheses () are in millimeters.

Door preparation template