

700AA, 40Y, XX4CY & XX700AA Series Louvers

700AA - Aluminum No Vision Door and Partition Louver for 1 3/8" - 2 1/4" Thick Doors

40Y - No Vision Door and Partition Louver for 1 3/8", 1 3/4" up to 2 1/4" Thick Doors

XX4CY - Thru-Bolt No Vision Door Louver for 1 3/4" Thick Doors

XX700AA - Thru-Bolt Aluminum No Vision Door and Partition Louver for 1 3/4" Thick Doors



Installation Instructions

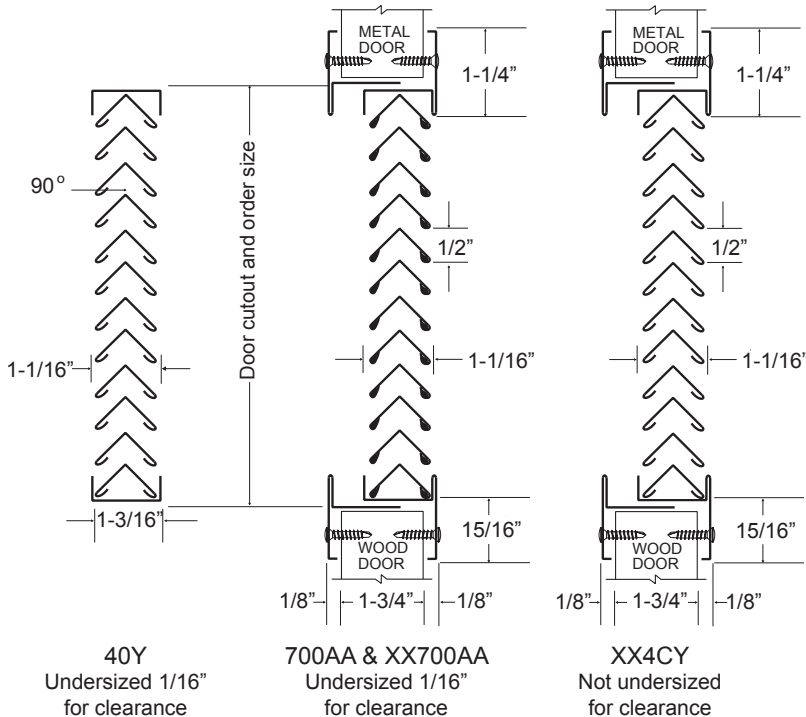

Installation Instructions for Louvers with frame

(XX4CY, 700AA, XX700AA)

1. Cut out door in accordance with door manufacturer's procedure.
2. Position outer frame with louver core, in-door cut-out, and insert and start all screws before fully tightening.
3. Tighten screws using a crisscross pattern. Use caution when using power screw-driving equipment to avoid stripping the material.
4. Position inner frame (700AA only), and secure to door using the same procedure.

Installation Instructions for Louver Cores

(40Y)

1. Cut out door in accordance with door manufacturer's procedure.
2. Install molding or glass stop type material (by others) on one side of where louver is to be mounted.
3. Position louver core, and install molding or glass stop type material (by others) on other side to hold louver securely in place.

① **Field Painting:** For best results, scuff finish with a scotch-brite pad prior to painting.

Customer Service

1-877-671-7011

us.allegion.com



© Allegion 2016
111367 Rev. 9/16-a