

Basics of electromagnetic locks

What it is

Magnetic locks, also known as mag locks or electromagnetic locks, open and secure a wide variety of openings. What sets them apart from most other locks is that they only have two parts that operate the locking mechanism—an armature and a coil assembly, which become magnetized when electric current passes through. This magnetic field secures the door and an actuator (scanner/push button) will turn it on/off. Electromagnetic locks are fail-safe by design. (Fail-safe means that if the power goes off the door will be unlocked.)

How it works

Magnetic locks use electromagnetism to control the entire locking mechanism. The electromagnet is fixed inside the door to protect it from being tampered, while the armature plate is mounted on the door's face. When the magnet is energized, it produces a powerful magnetic force, which bonds to the armature and thus locks the door. To allow access or egress, a switch or actuator must be provided to de-energize the magnet. Because electromagnetic locks use magnetic force they do not require a mechanical latch bolt to lock the door.

Ideal applications

Magnetic locks offer several advantages including they cannot be picked or tampered with. Electromagnetic locks are used to secure the door in conjunction with push bars, request-to-exit devices or credential readers for fail-safe applications when code compliance permits.

These locks are solutions for:

- Single standalone doors
- Doors that require a basic and/or inexpensive level of access control
- Glass doors that need to electronically control access
- Emergency exits, or openings where the exit must be controlled

Installation

Electromechanical locks boast a simple and intuitive design with only two components, namely a magnet and armature plate. Use of a strike often requires an integrator or installer to cut openings in the frame or make modifications to the opening. With an electromagnetic lock, the construction is generally limited to drilling holes in the frame, which is both less intrusive and less labor-intensive.

Special features/functionality

- Delayed egress of 15-30 seconds
- Magnetic Bond Sensor (MBS) monitors the strength of the bond between the lock and armature so you know the door is secure
- Interlock capabilities to set conditions that control two doors
- Relock Time Delay (RTD) provides a relock delay that is adjustable from 0.5 to 30 seconds



Schlage® electromagnetic lock portfolio

The broad portfolio of Allegion's electromagnetic locks offers a solution for most every application. Whether it's securing a hospital laboratory, monitoring a controlled area in an airport or providing traffic control for doors in an institutional building, Schlage magnetic door locks are designed for both unique applications and specification. For aftermarket needs, the Locknetics portfolio offers simple solutions at practical price points.

M400 Series

A robust line of electromagnetic locks with unique design elements that make them easy to install and secure.

- Bayonet mounting feature that allows installers to have their hands free during the mounting process
- Innovative design that allows for RH/LH configuration in the field
- Strong hold force for heavy duty doors
- Armature mount that pivots to compensate for slight opening imperfections
- Non-handed and symmetrical for optimal placement of the magnet
- Optional mounting kits: Top Jamb Mount, Double and Glass Door
- Plus Package with magnetic bond sensor, relocking time delay, door status monitor

Electromagnetic specialty locks

M490DE—Delayed egress

- Delays egress with 15-second timer (includes integrated alarm)
- Designed to meet NFPA 101 and BOCA, UL 10C 3 hr fire rating, UL 294 and BHMA 1500 lb. hold force

M490G—Exterior gates

- Weather resistant for exterior swinging and sliding gates
- BHMA 1500 lb. hold force rated

GF3000—Shear lock

- Available in mortise and surface mounts
- Concealed locking mechanism enhances security and appearance
- UL 10C 3 hr fire rating, BHMA 1500 lb. hold force

320M—MiniLine mortise

- Designed for interior sliding doors
- UL 10C 3 hr fire rating, UL 1034 listed

[Schlage electromagnetic locks](#)

[Code requirements for electromagnetic locks](#)

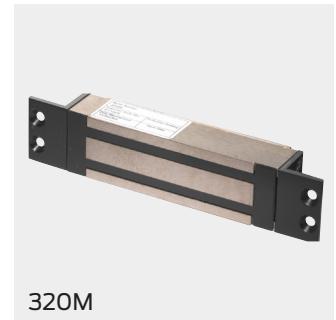

Learn more about Schlage electromagnetic locks by calling 877-929-4350 or [contacting an Allegion spec writer](#).

About Allegion

Allegion (NYSE: ALLE) is a global pioneer in safety and security, with leading brands like CISA®, Interflex®, LCN®, Schlage®, SimonsVoss® and Von Duprin®. Focusing on security around the door and adjacent areas, Allegion produces a range of solutions for homes, businesses, schools and other institutions. Allegion is a \$2 billion company, with products sold in almost 130 countries. For more, visit www.allegion.com.