



640059-00

250DT

FALCON®

Dummy Pushbar
Barra de empuje del maniquí
Fausse barre antipanique

Installation Instructions
Instrucciones de Instalación
Notice d'installation

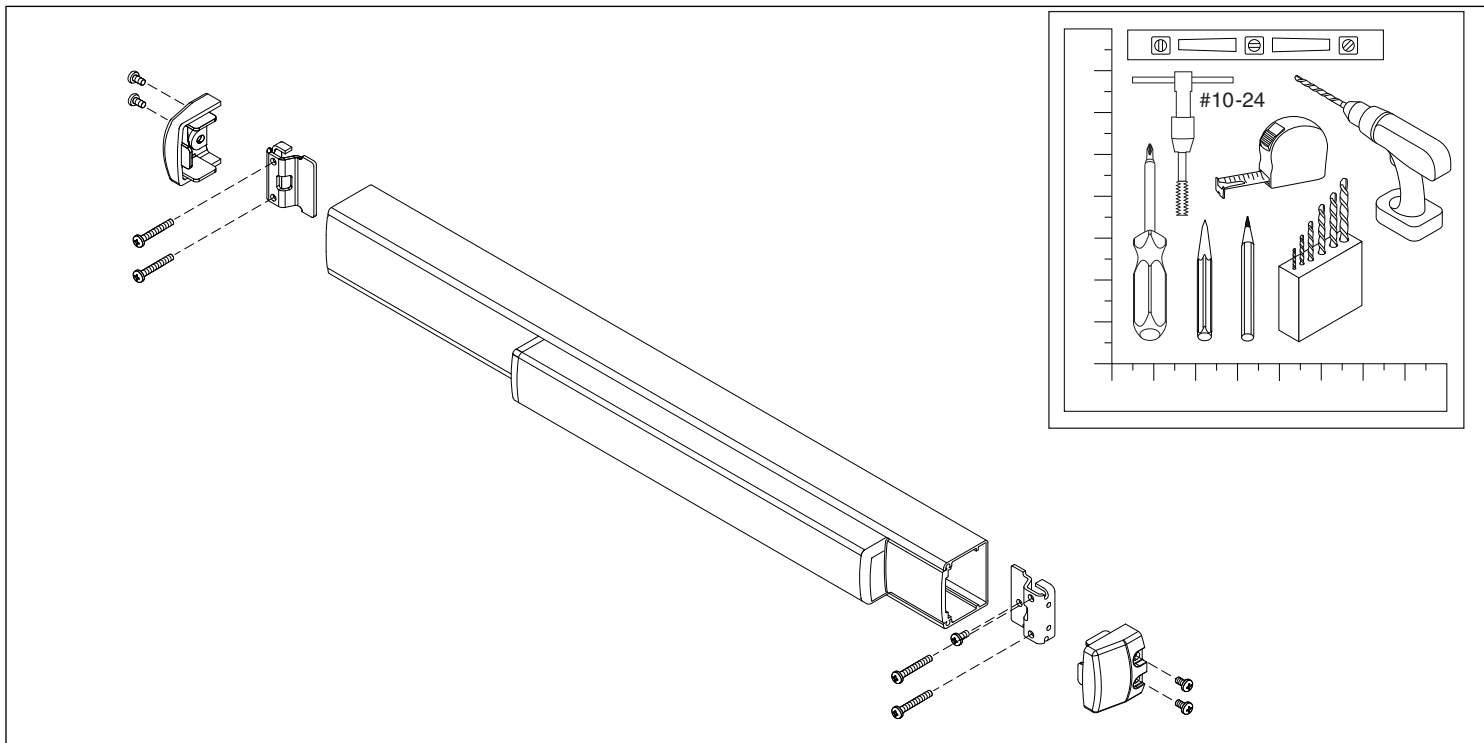

1 Draw Exit Device Centerline (☉)
Sacar la Línea central del dispositivo de salida (☉)
Tracer l'axe du dispositif de sortie (☉)

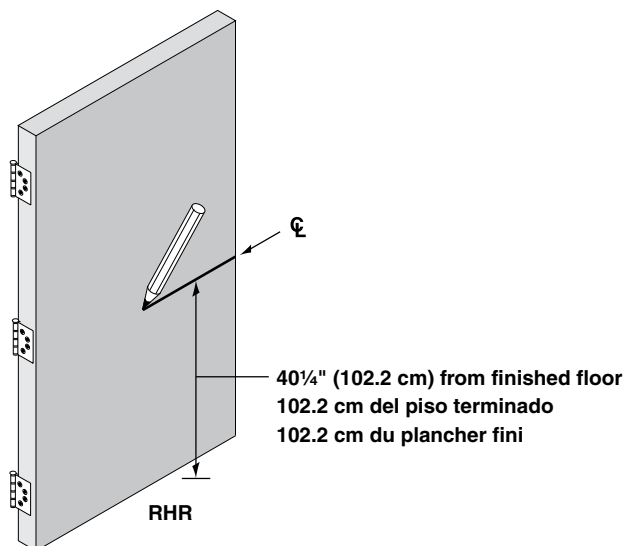

2 Center Device Between Jamb
Dispositivo central entre jambas
Centrer le dispositif entre les montants

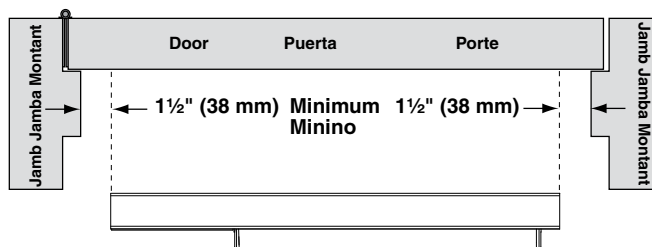

Note: If device has less than 1 1/2" (38 mm) clearance on each end, see step 3 for device cutting.

Nota: Si el dispositivo tiene un claro inferior a (38mm) en cada extremo consulte el paso 3 para el corte del dispositivo.

Note: Si le dispositif ne dispose pas d'un espace libre de 38 mm de chaque côté, voir l'étape 3 pour la coupe du dispositif.



Customer Service Servicio al cliente Service à la clientèle

1-877-671-7011

www.allegion.com/us

© Allegion 2014
Printed in U.S.A.
640059-00 Rev. 01/14-c

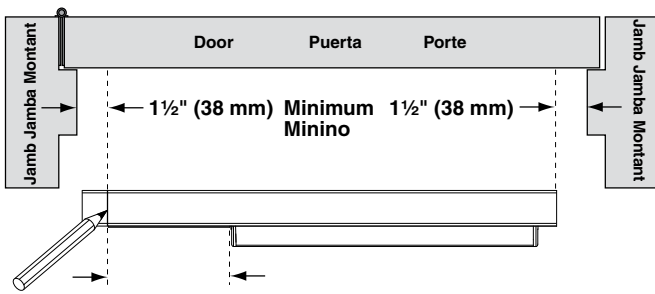
3**If Necessary, Cut Device****Si es Necesario, Corte el Dispositivo****Couper le Dispositif si Nécessaire**

Minimum / Mínimo

5 1/4" (133 mm)	EA 7 1/2" (191 mm)
--------------------	--------------------------

Cover plate flush
Alinee la placa de la cubierta
Plaque-couvercle encastrée

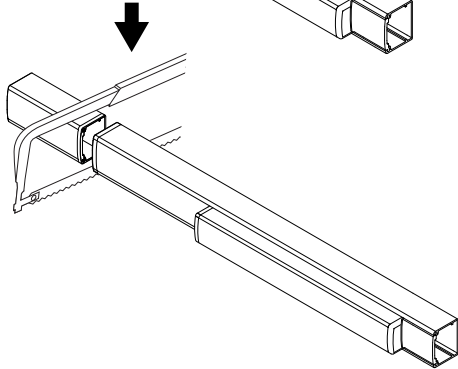
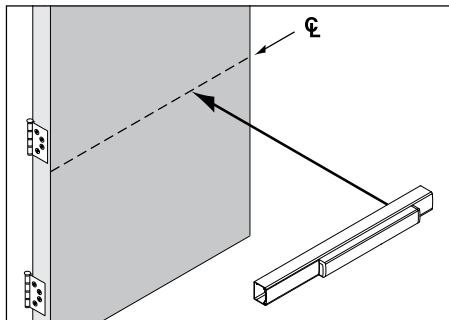
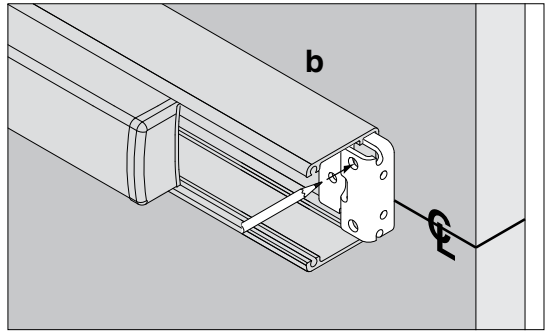
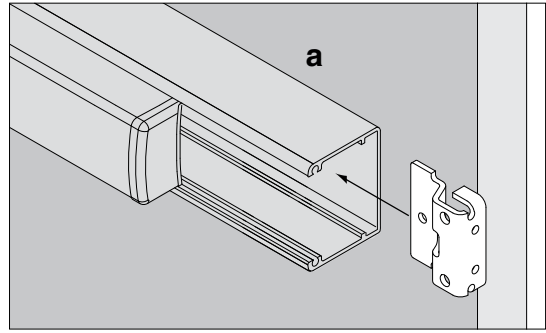
**4****Align Device to Centerline****Alinee el Dispositivo a la Línea Central****Aligner le Dispositif avec L'axe****5****c****Metal/Metal/Métal**

#25

#10-24

Wood/Madera/Bois

1/8" (3 mm) x 1" (25 mm)

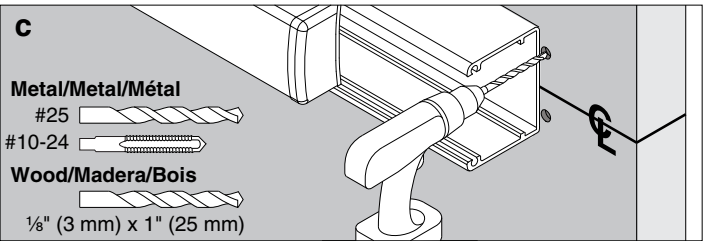
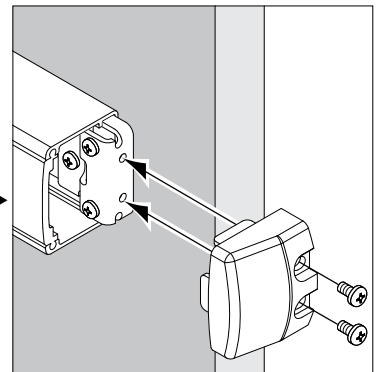
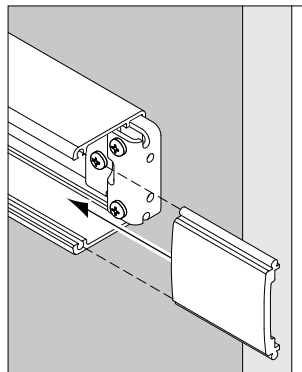
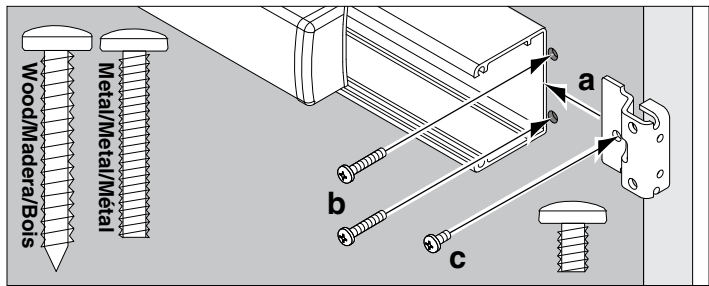
**6**

7 Mark and Prepare 2 Holes
 Marque y Prepare 2 Orificios
 Marquer et Préparer 2 Orifices

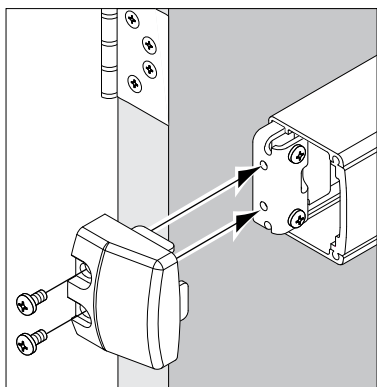
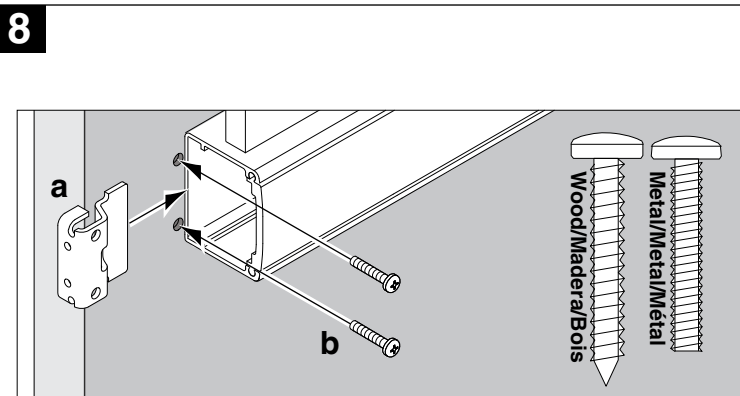
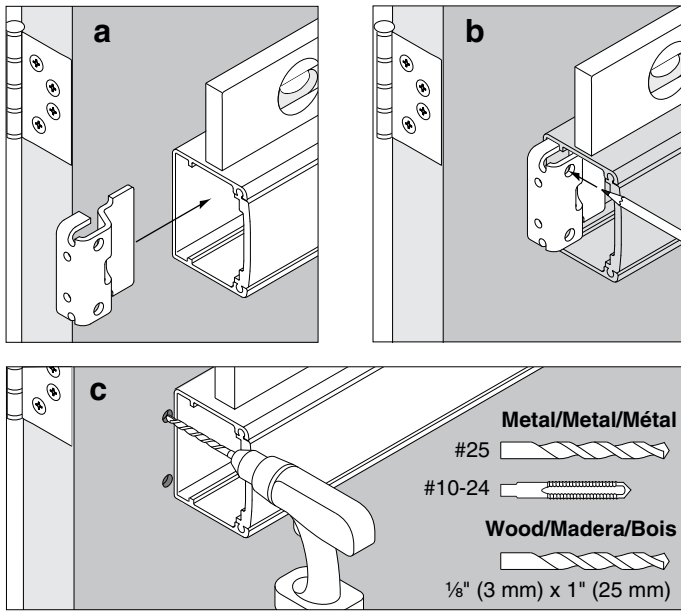

If AE Device, Complete Steps 9 - 13
 Si es un dispositivo EA, complete los pasos 9 a 13
 Pour un dispositif EA, compléter les étapes 9 à 13

9 Install Cylinder (AE-KOR Only)
 Instale el Cilindro (solamente AE-KOR)
 Installer le Cylindre (AE-KOR seulement)

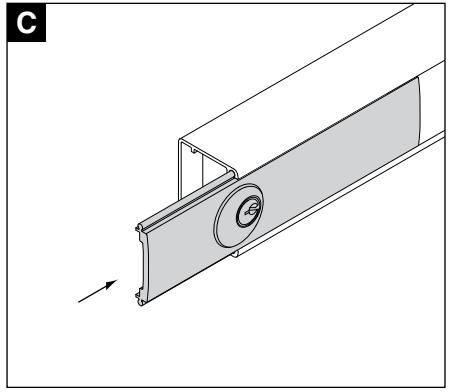
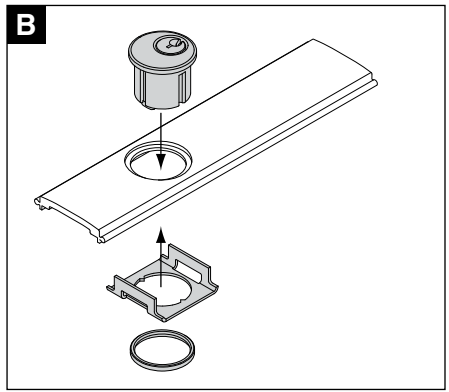
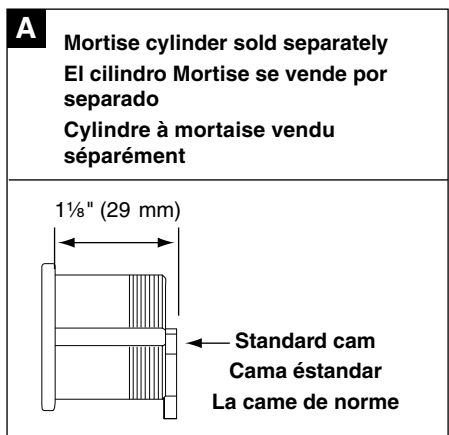

10

Drill Wire Access Hole
Perfore el Orificio de Acceso del Cabl
Orifice D'accès pour Câble

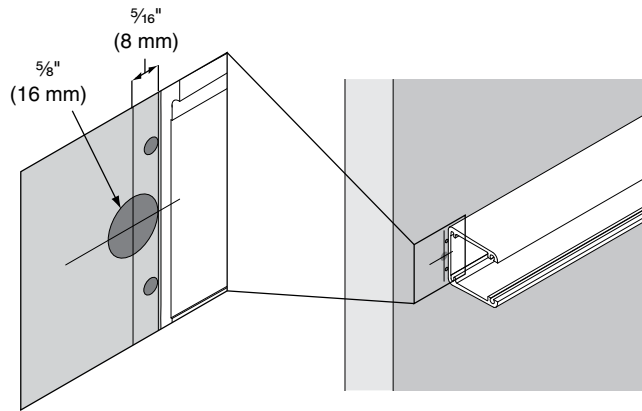
**11**

Review Function of Switch
Revise la Función del Interruptor
Réviser la Fonction de L'interrupteur



Pushbar up
 Barra de empuje hacia arriba
 Barre antipanique vers le haut

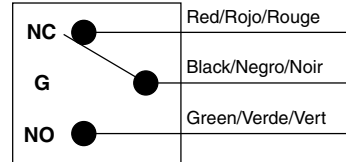

Pushbar down
 Barra de empuje hacia abajo
 Barre antipanique vers le bas

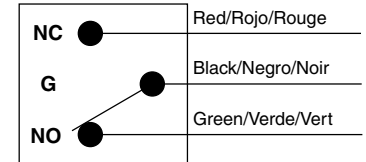
**12**

Route Wires Through Mounting bracket
Enrute los Cables a Través de la Ménsula de Montaje
Acheminer les Câbles par le Support de Montage

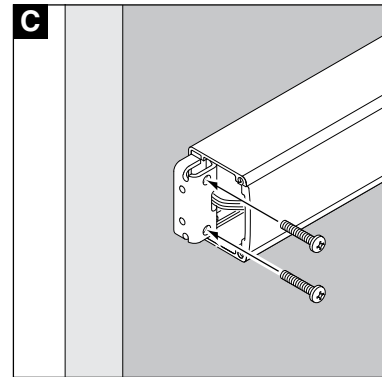
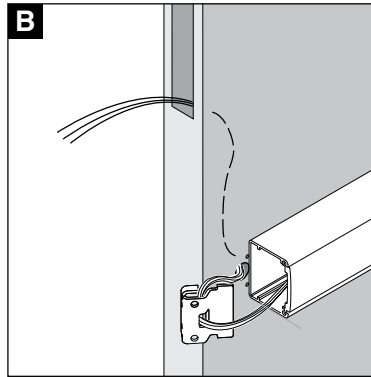
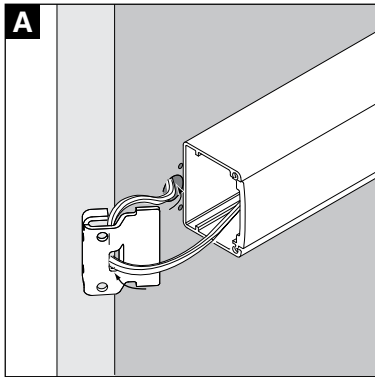
**13**

Route wires through frame using Electric Hinge or Power Transfer
Enrute los Cables a Través del Marco Utilizando la Bisagra Eléctrica o Transferencia de Energía
Acheminer les Câbles par la Structure en Utilisant une Charnière Électrique ou une Transmission de Puissance

