

# ELECTRIC DOGGING INSTALLATION INSTRUCTIONS

**FALCON**<sup>®</sup>

**ELECTRIC  
DOGGING**

**D-5156-B**

Date: **05-29-2015**

**THE FOLLOWING INSTALLATION INSTRUCTIONS PERTAIN TO THE INSTALLATION OF AN ELECTRIC DOGGING FEATURE IN AN EXISTING DEVICE. IF YOUR SITUATION IS A NEW INSTALLATION WITH THE ELECTRIC DOGGING FEATURE INSTALLED IN THE DEVICE, OMIT STEPS 1 THRU 4 AND START WITH STEP 5.**

1. REMOVE DEVICE FROM DOOR AND SLIDE CHANNEL COVER OUT OF DEVICE CHANNEL. THIS COVER WILL BE REPLACED BY THE COVER SUPPLIED WITH THE ELECTRIC DOGGING UNIT.

**NOTE: ED RETROFITS WITH KEY-OVERRIDE ON FIRE RATED DEVICES WILL REQUIRE MOVING THE FIRE LABEL FROM THE EXISTING CHANNEL COVER TO THE KOR CHANNEL COVER.**

2. REMOVE DOGGING MECHANISM (FROM PANIC DEVICES ONLY) BY REMOVING THE MOUNTING SCREW HOLDING IT IN PLACE, THIS WILL NOT BE USED IN THE FINAL DEVICE INSTALLATION.
3. IF THE BLANK OR KEY-OVERRIDE CHANNEL COVER SUPPLIED IS TOO LONG, SEE *"PROCEDURE FOR CUTTING DEVICE AND CHANNEL COVER TO DOOR SIZE"* (SEE PAGE 4).

**NOTE: THE MINIMUM LENGTH FOR CHANNEL COVER IS:**

**7" FOR 19 SERIES DEVICES AND  
7-1/2" FOR 17 & 18 SERIES DEVICES**

**NOTE: AVOID CONTAMINATING THE ED UNIT WITH FOREIGN MATERIAL SUCH AS METAL CHIPS, DIRT, ETC.**

**FIGURE 1  
ED UNIT  
INSTALLATION**

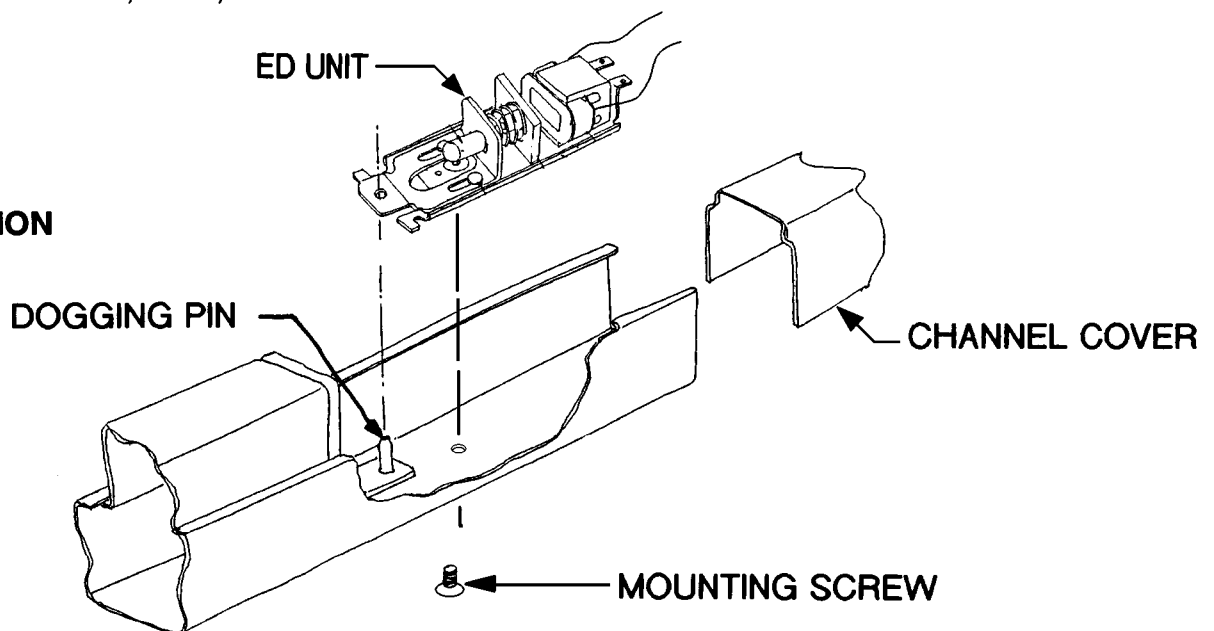

4. REMOVE ED UNIT MOUNTING SCREW. INSTALL ELECTRIC DOGGING (ED) UNIT (FOR FIRE RATED DEVICES THAT ARE INSTALLED WITHOUT A DOGGING PIN IN THE PUSHBAR (REFER TO PAGE 1, FIGURE 1), SEE FIGURE 2 BELOW) INTO DEVICE CHANNEL BY SLIDING IT FROM OPEN CHANNEL UNTIL THE ED SLIDE PLATE CONTACTS THE DOGGING PIN (OR THE RETROFIT PIN CONTACTS THE TOUCHBAR). LIFT THE ED UNIT AND CONTINUE TO ED FORWARD UNTIL THE DOGGING PIN SLIDES INTO THE HOLE IN THE ED SLIDE PLATE (OR THE RETROFIT PIN SLIDES INTO THE HOLE IN THE PUSHBAR). INSTALL ED UNIT RETAINING SCREW (SUPPLIED WITH ED UNIT) FROM DEVICE CHANNEL REAR SIDE (SEE PAGE 1, FIGURE 1) AND SECURELY TIGHTEN. DO NOT USE THE MOUNTING SCREW FROM THE DOGGING MECHANISM (REFER TO STEP 2).

**FIGURE 2**

**RETROFIT ED UNIT  
ASSEMBLY INSTRUCTION  
[FOR FIRE RATED DEVICE  
WITHOUT DOGGING PIN  
IN PUSHBAR (SEE FIGURE 1,  
PAGE 1)]**

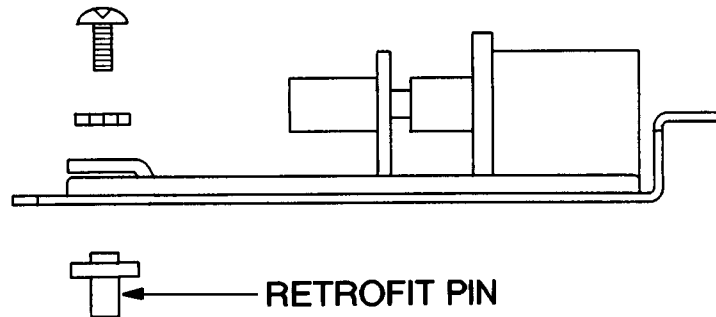

5. IF ED UNIT IS SHIPPED WITH THE DEVICE, SLIDE CHANNEL COVER FROM CHANNEL.
6. **FOR DEVICE WITH KEY-OVERRIDE FEATURE ONLY, INSTALL CYLINDER (SEE BELOW):**
- INSERT KEY CYLINDER (SUPPLIED) INTO CYLINDER ACCESS HOLE IN ED CHANNEL COVER WITH KEYWAY HORIZONTAL AS IN FIGURE 3. IF USING A CYLINDER OTHER THAN THE ONE SUPPLIED BY MONARCH, A 1-1/8" LONG MORTISE CYLINDER WITH A STANDARD "A" CAM (5/16" WIDE, 3/4" LONG) IS RECOMMENDED; LONGER CYLINDERS REQUIRE SPACERS.
  - SLIDE CYLINDER RETAINER BRACKET OVER THREADED END OF KEY CYLINDER (SEE FIGURE 3) INSIDE ED CHANNEL COVER. NOTE: NOTCHES IN CYLINDER BRACKET ENGAGE RECESS NOTCHES IN CYLINDER TO PREVENT CYLINDER FROM TURNING.
  - THREAD CYLINDER NUT ONTO KEY CYLINDER, CHECK ORIENTATION OF KEYWAY WITH RESPECT TO CHANNEL COVER (SEE FIGURE 3), THEN TIGHTEN SECURELY.

**FIGURE 3**

**CYLINDER INSTALLATION  
FOR ED WITH KEY-OVERRIDE  
FEATURE**

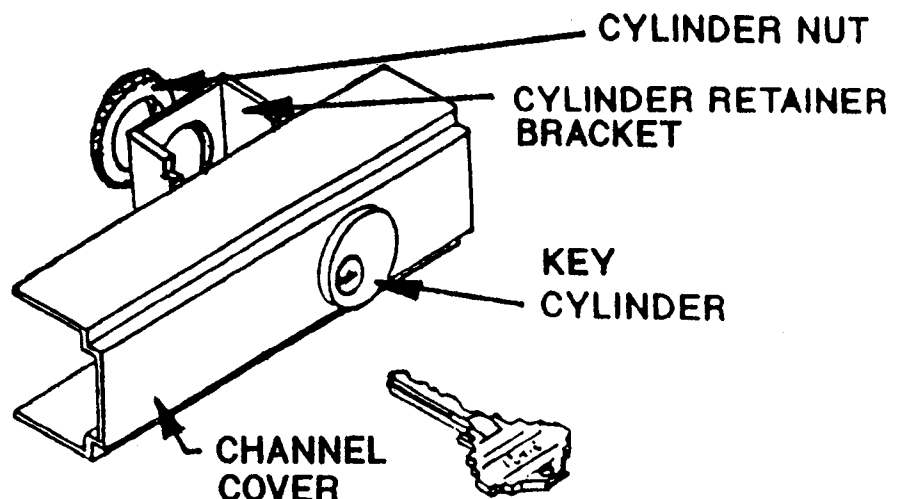

7. INSTALL DEVICE PER DEVICE INSTRUCTIONS (WITH PROPER ADJUSTMENT FOR SURFACE AND CONCEALED VERTICAL ROD DEVICES), OMITTING END CAP, END CAP MOUNTING BRACKET AND BLANK (OR KEY-OVERRIDE) CHANNEL COVER INSTALLATION AT THIS TIME.
8. CONNECT THE WIRES FROM THE ED UNIT TO THE LUT-2 POWER SUPPLY.  
**NOTE: FOR FIRE RATED DEVICES - LUT-2 POWER SUPPLY MUST BE TIED INTO FIRE ALARM CIRCUIT.**
9. WITH THE ED UNIT ENERGIZED, FULLY DEPRESS THE PUSHBAR AND ADJUST ED UNIT (SEE FIGURE 4 AND CHART BELOW).

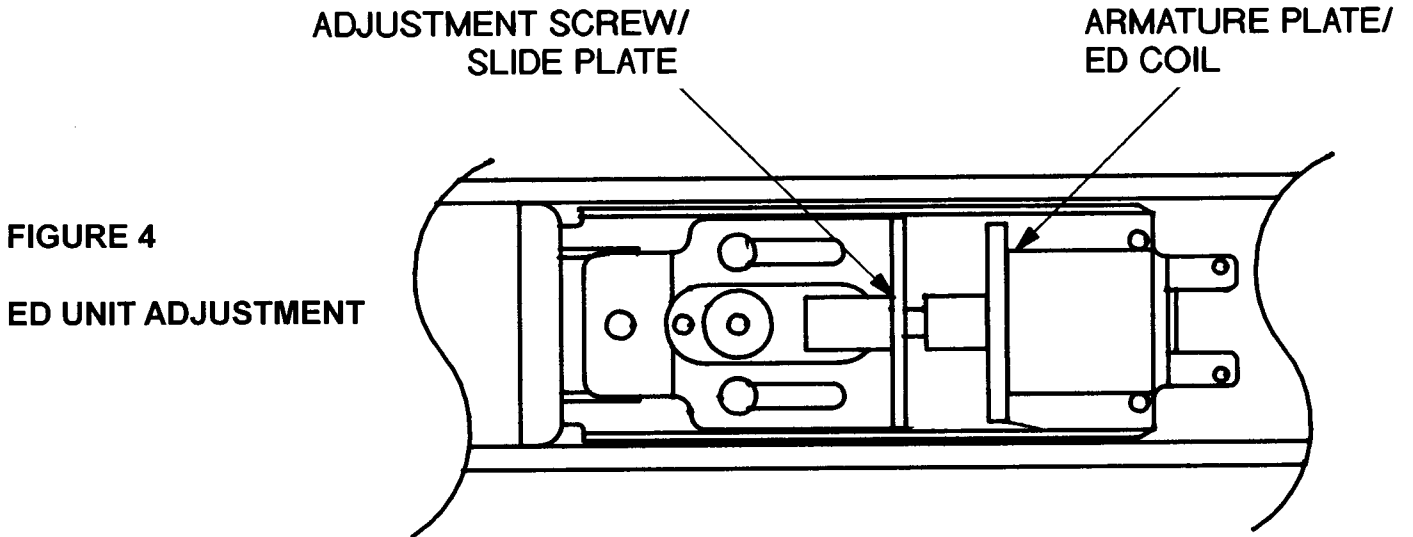

IF THERE IS A GAP BETWEEN.....	DE-ENERGIZE ED UNIT AND...
ADJUSTMENT SCREW & SLIDE PLATE	PULL THE ADJUSTMENT SCREW AWAY FROM THE SLIDE PLATE AND SCREW IT INWARD. THEN, RE-ENERGIZE THE ED UNIT AND CHECK GAPS.
ARMATURE PLATE & ED COIL	PULL THE ADJUSTMENT SCREW AWAY FROM THE SLIDE PLATE AND SCREW IT OUTWARD. THEN, RE-ENERGIZE THE ED UNIT AND CHECK GAPS.
NEITHER ADJUSTMENT SCREW & SLIDE PLATE OR ARMATURE PLATE & ED COIL (NO GAPS)	ADJUSTMENT IS CORRECT. CONTINUE WITH DEVICE INSTALLATION.

10. INSTALL CHANNEL COVER, END CAP MOUNTING BRACKET AND CHANNEL END CAP PER DEVICE INSTALLATION INSTRUCTIONS.

# PROCEDURE FOR CUTTING DEVICE & BLANK OR KEY-OVERRIDE CHANNEL COVER TO DOOR SIZE

1. DETERMINE DEVICE LENGTH REQUIRED (SEE FIGURE 5 BELOW).
  - A. LOCATE VERTICAL  $\varnothing$  ON DOOR FOR THIS INSTALLATION.
  - B. MEASURE DISTANCE "Y" FROM VERTICAL  $\varnothing$  TO STOP SURFACE ON HINGE SIDE.
  - C. SUBTRACT 1" FOR CLEARANCE
  - D. LENGTH OF DEVICE FROM VERTICAL  $\varnothing$  TO END EQUALS "X".

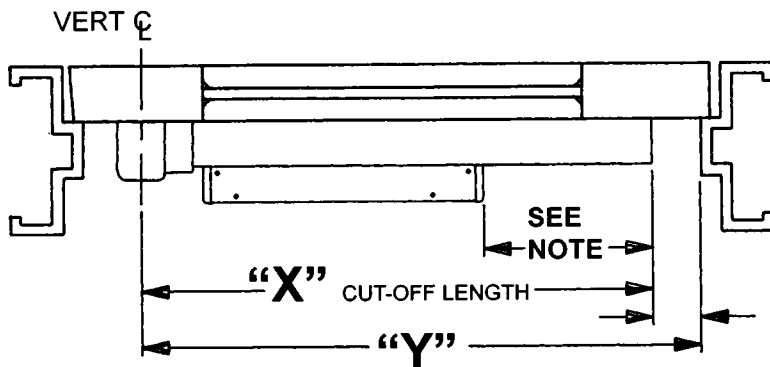

**FIGURE 5  
DEVICE SIZING**

**NOTE:**  
**19 SERIES: 7" MINIMUM**  
**17 & 18 SERIES: 7-1/2" MINIMUM**

**LHR SHOWN**

2. CUT DEVICE TO LENGTH AND DRILL.
  - A. MARK CUT-OFF POINT ON DEVICE CHANNEL AND CHANNEL COVER.
  - B. CUT BOTH PIECES ON MARK AND REMOVE ALL BURRS.
 

**NOTE: REMOVE ED UNIT PRIOR TO CUTTING.**
  - C. REMOVE BLANK OR KEY-OVERRIDE CHANNEL COVER AND DRILL 5/16" DIA. HOLE ON  $\varnothing$  OF CHANNEL AND 5/16" FROM CUT END (FIGURE 6).
  - D. FOR 17 & 18 SERIES DEVICES (IN NON-PAINTED FINISHES) DRILL AN 11/16" DIA. HOLE 5/16" FROM THE END OF THE CUT END OF THE BLANK OR KEY-OVERRIDE CHANNEL COVER (FIGURE 7). REMOVE MATERIAL SHOWN FROM CHANNEL COVER (FIGURE 8).
  - E. PROCEED WITH DEVICE INSTALLATION.

**FIGURE 6**

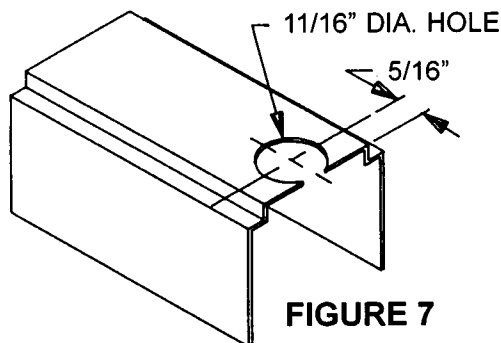
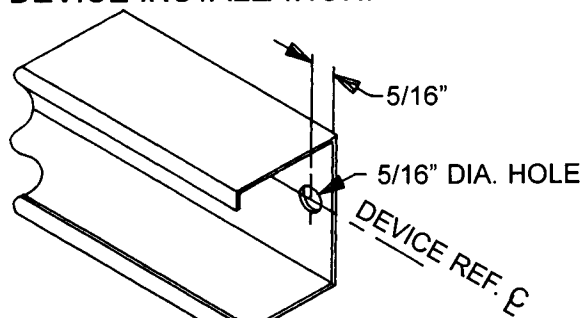

**FIGURE 7**

**FIGURE 8**

