

## INSTALLATION INSTRUCTIONS FOR EXIT ALARMS

The following installation instructions pertain to installation of exit alarm in existing device. If your situation is a new installation (alarm shipped with device), omit steps 1 thru 4 and proceed with Step 5.

1. If installed on door, remove device and slide channel cover out of device channel. This cover is replaced by a new alarm channel cover.
2. Remove dogging mechanism (panic devices) by removing mounting screw holding mechanism in place. This mechanism will not be used in this alarm installation.
3. If alarm channel cover supplied is too long, see "Procedure for cutting device and alarm channel cover to door size" (See reverse side). **NOTE!** The minimum length for channel cover is 7" long. **NOTE!** Avoid contaminating alarm unit with foreign material such as metal chips, dirt, etc.
4. Install alarm unit (For fire devices see Fig. 2 reverse side) into device channel by sliding it from open channel end up to dogging pin (See Fig. 1). lift alarm unit and insert alarm unit actuator over dogging pin. Install alarm unit retaining screw (supplied with unit) from device channel rear side (See Fig 7) and securely tighten. Do not use mounting screw from dogging mechanism.
5. If alarm unit is shipped with device, slide channel cover from channel.
6. Insert key cylinder (supplied) into cylinder access hole in alarm channel cover with keyway oriented as in Fig. 1. 1 1/8" long mortise cylinder with standard 'A' cam recommended. Longer cylinders with appropriate spacers can be used.
7. Slide cylinder retainer bracket over threaded end of key cylinder (See Fig. 1) inside alarm channel cover. **NOTE!** Notches in cylinder bracket engage recess notches in cylinder to prevent cylinder from turning.
8. Thread cylinder nut onto key cylinder, check orientation of keyway with respect to channel cover (See Fig. 1), then tighten securely.
9. Check battery of alarm unit to see that it is positively engaged into battery post clip. (See Fig. 1).
10. Install device per device installation instructions.
11. Slide alarm channel cover into channel properly orienting cover with respect to device (See Fig. 1), push alarm channel cover up to push-bar of device.

12. With alarm channel cover installed, turn key in clockwise direction. There will be an audible 'chirp' and the visual indicator will flash red. The alarm unit will continue to 'chirp' and flash green once a second for 15 seconds allowing authorized personnel passage through door before alarm goes into armed position which is indicated by a flash of red light and a final long 'chirp'.
13. The armed condition will be indicated by a green flash of light from visual indicator every 30 seconds.
14. When pushbar is depressed, the alarm will sound continuously until the key cylinder is turned counter clockwise. If not manually reset, alarm will sound 10 minutes continuously then reset automatically.
15. Apply 'Push to Open' decal to push bar or on door adjacent to alarm. Make sure surface is clean for good adhesion. (See Fig. 3 - reverse side).

### NOTE

LOW BATTERY ALERT IS INDICATED BY RED FLASH  
& AUDIBLE CHIRP SOUND EVERY 15 SECONDS.  
IF THIS OCCURS REPLACE BATTERY.  
BATTERY LIFE IS APPROX. 6 MONTHS

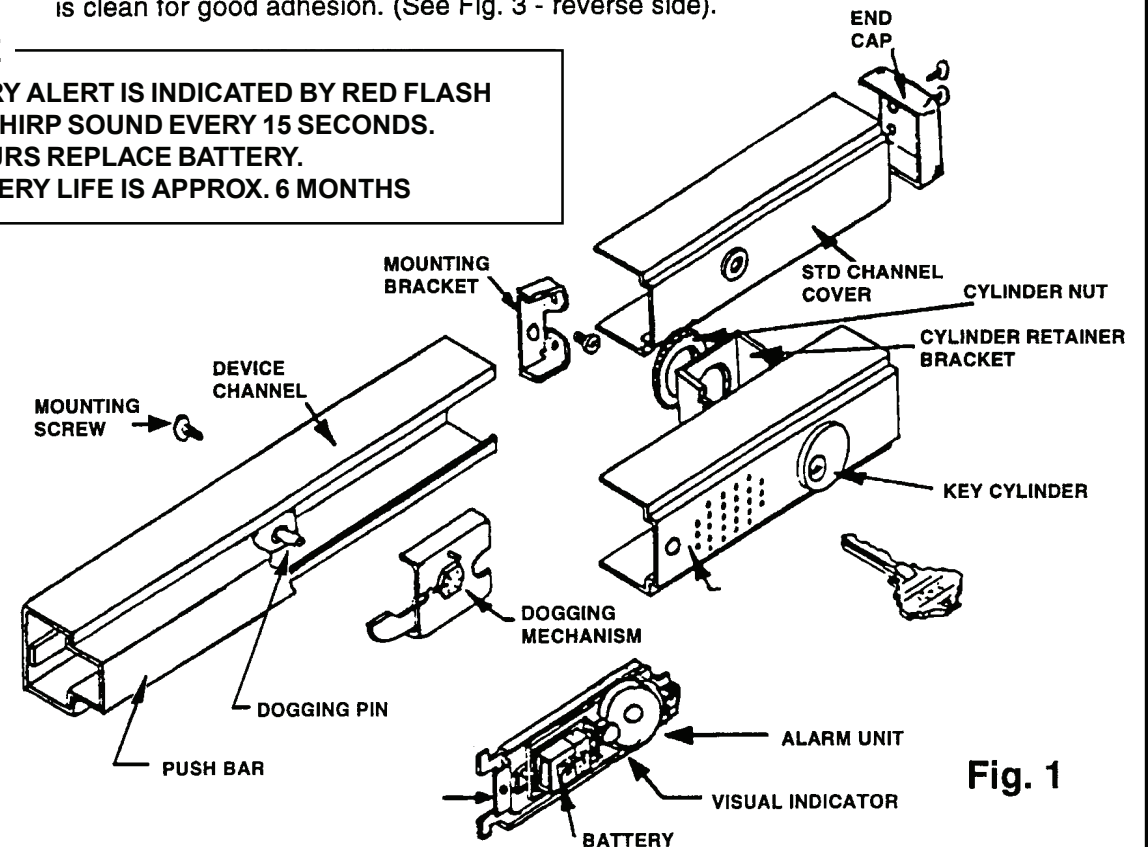

Fig. 1

**FALCON**<sup>®</sup>

TITLE: **EXIT ALARM  
INSTRUCTION**



**D-5155**

# Procedure For Cutting Device & Alarm Channel To Door Size

## 1. DETERMINE DEVICE LENGTH REQUIRED

- Locate vertical C/L on door for this installation.
- Measure distance "Y" from vertical C/L to stop surface on hinge side. See Fig. 1
- Subtract 1" for clearance.
- Length of device from C/L chassis mounting to end and equals "X".

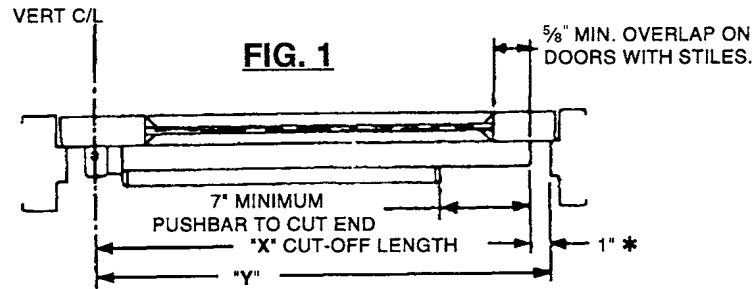

## 2. CUT DEVICE TO LENGTH AND DRILL

- Mark cut-off point on channel and alarm channel cover. Cut both pieces and deburr.
- Remove alarm channel cover and drill  $\frac{5}{16}$ " dia. hole on C/L of channel and  $\frac{5}{16}$ " from cut end. See Fig. 2A.
- Proceed with device installation.

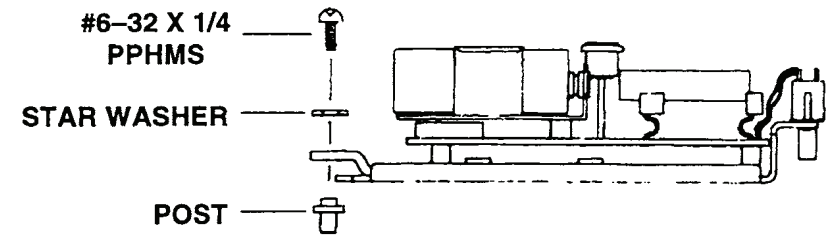
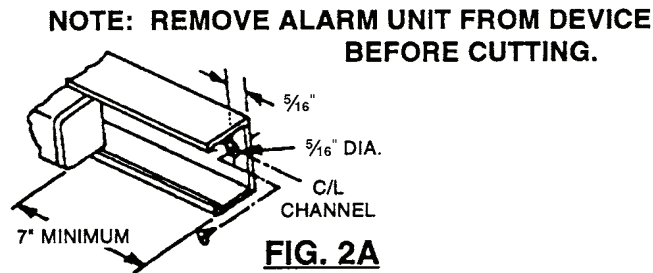

FIG. 2

## RETROFIT ALARM UNIT ASSY. INSTRUCTION (FIRE RATED DEVICE)

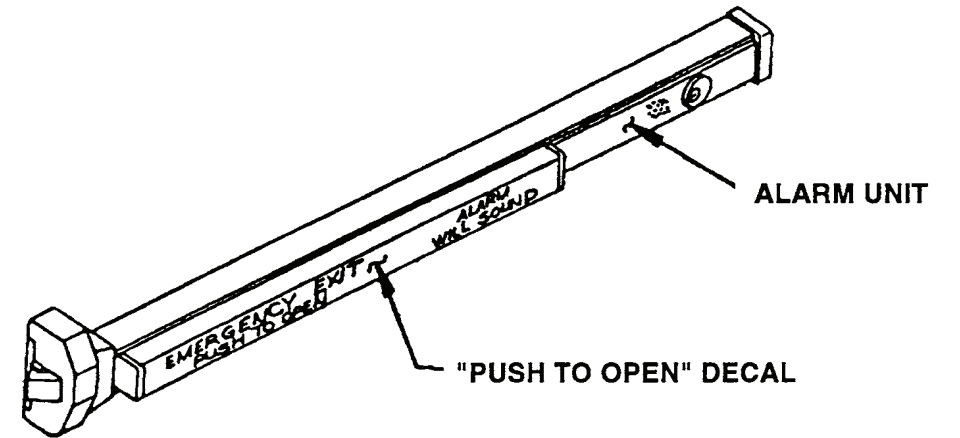

FIG. 3

## DECAL INSTALLATION



© Allegion 2015  
Printed in U.S.A.  
D-5155 Rev. 05/15-b

**FALCON**

TITLE: **EXIT ALARM  
INSTRUCTION**



**D-5155**