



030388-000-70

Mounting and Rehanding

# RW Series Retrofit Lever Trim

# FALCON®

Installation Instructions

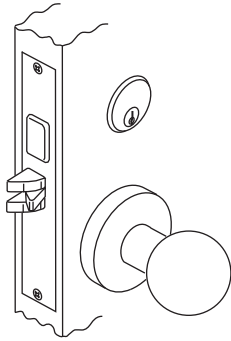

### STEP ONE:

Remove all existing trim from door, including cylinder if one is installed.

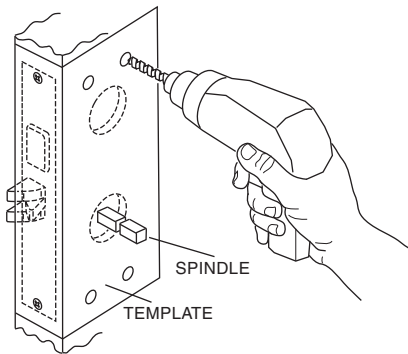

### STEP TWO:

Insert inner and outer spindles into lock hubs. *NOTE: Because of various hub sizes, be sure spindles fit properly.* Place the enclosed template over the spindle. Align with door edge and mark the four (4) thru-bolt hole locations. This should be done to both sides of the door. Drill the four (4) holes halfway through from each side of door.

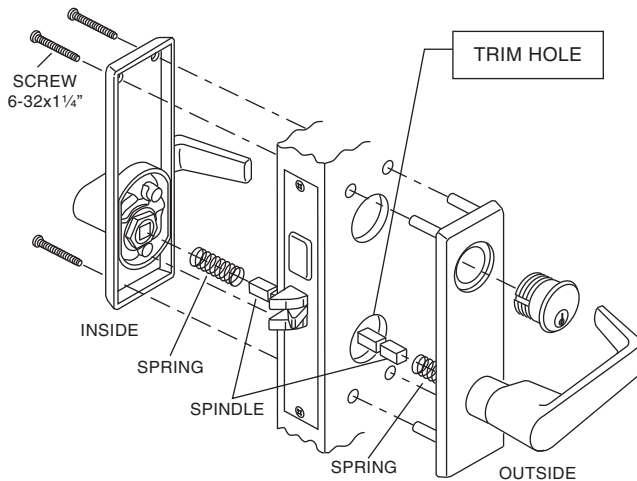

**IMPORTANT:** It may be necessary to enlarge the trim hole due to varying door preps. Falcon retrofit trim requires both sides to be 1 1/8" diameter minimum to clear trim mechanism.

**STEP THREE:** Before mounting the trim, be sure to insert spindle springs into each lever. With spindle in outer hub, place outer trim over spindle with posts going into thru-holes. Place inside trim over spindle and install the four (4) mounting screws. Before screws are tightened, check to see that both levers are operating properly. If reinstalling the cylinder, determine if a blocking ring is required. Tighten set screw then check cylinder for proper function. Tighten the four (4) trim mounting screws.

### REPLACEMENT PARTS

5/16"		5/16"	Spindle	P/N 021242-001-30
9/32"		5/16"	Spindle	P/N 030329-000-30
3/8"			Adapter	P/N 030319-000-30
			Spring	P/N 021244-001-60



Customer Service

1-877-671-7011 [www.allegion.com/us](http://www.allegion.com/us)

© Allegion 2014  
Printed in U.S.A.  
030388-000-70 Rev. 10/14-d

# RE-HANDING INSTRUCTIONS FOR FALCON RW SERIES LOCK TRIM

**Example shown is a right hand being changed to a left hand  
Reverse sequence to change from left to right hand**



Note: Inside trim is always opposite the outside trim

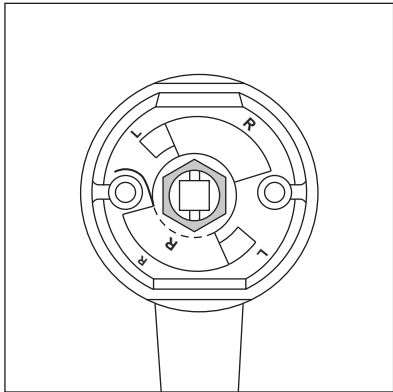

1. Holding lever as shown, bend tab of lockwasher back flat. Remove nut.

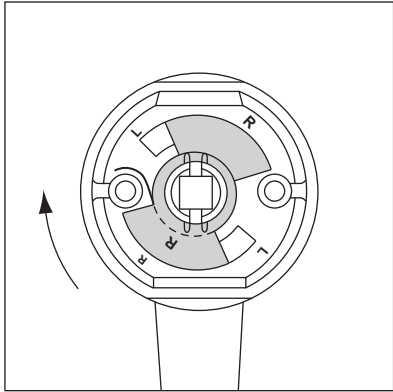

2. Holding lever securely, rotate rose assembly clockwise slightly, and remove plate and lockwasher.

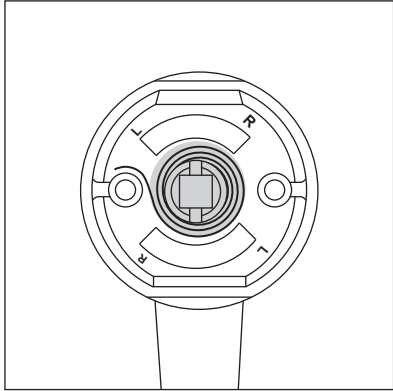

3. Using caution, allow rose assembly to rotate counterclockwise to relieve spring tension.

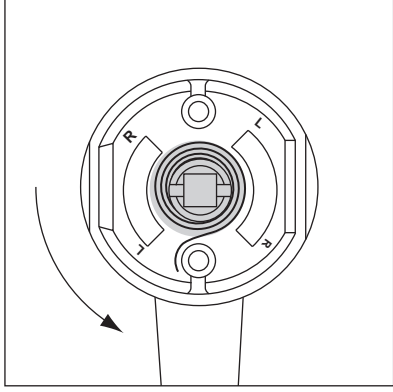

4. Remove spring and reinstall with spring hook on opposite side of post.

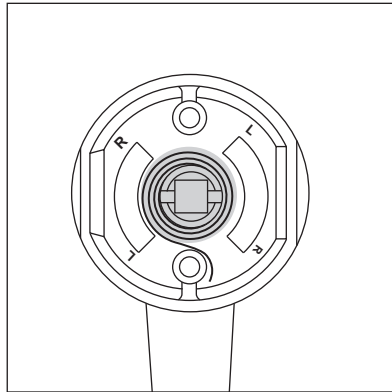

5. Holding lever securely, rotate rose assembly counterclockwise slightly past 90 deg.

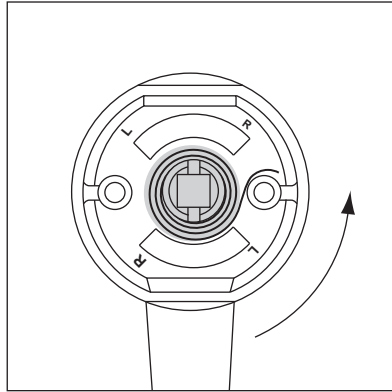

6. Reinstall plate with "L" side up and in line with "L" on rose assembly.

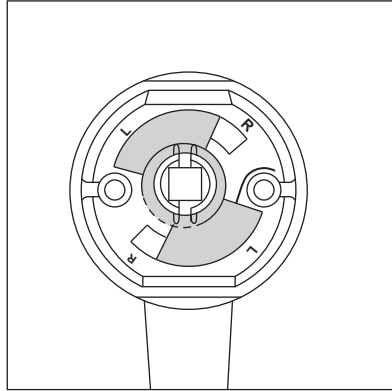

7. Reinstall lockwasher and nut. Tighten nut and then back off slightly until rose assembly rotates freely under plate. Bend up one tab of lockwasher against nut.

8.500

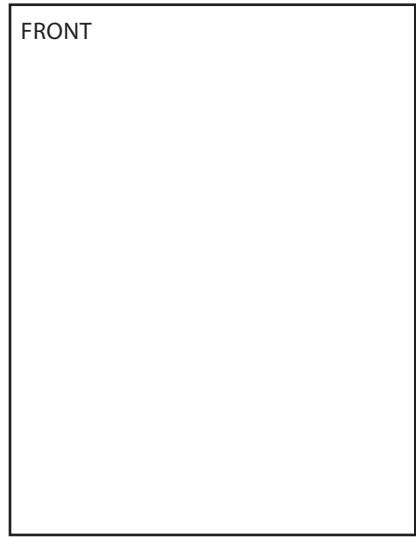

11.000

BEGINNING SHEET

8.500



3.670

FOLDED SHEET

Additional Notes:
1. None

Revision History						Revision Description:					
A	B	C	D	E	F	D > Revised artwork					
4955-255	0790	6683									
Material						Edited By		Approved By		EC Number	Release Date
White Paper						J. Ellis		M. Roberts		xxxxx	10/14
Notes						Title					
1. printed two sides						RW Series Retrofit Lever Trim					
2. printed black						Creation Date		Number		Revision	
3. tolerance ± .13						10-22-14		030388-000-70		D	
4. printed in country may vary						Created By		Activity		© Allegion 2014	
5. drawings not to scale						J. Ellis		3899 Hancock Expwy Security, CO 80911			
						Software: InDesign CS6					