



SC60A Series/Serie/Série

FALCON®

44036

Heavy Duty Arm Models, SC61A (1-5 Adj.)
Modelos con brazo para uso industrial, SC61A (1-5 Adj.)
Modèles avec bras à usage industriel, SC61A (1-5 Adj.)

Installation Instructions
Instrucciones de Instalación
Instructions d'installation

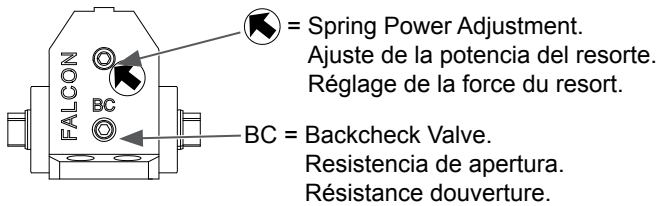
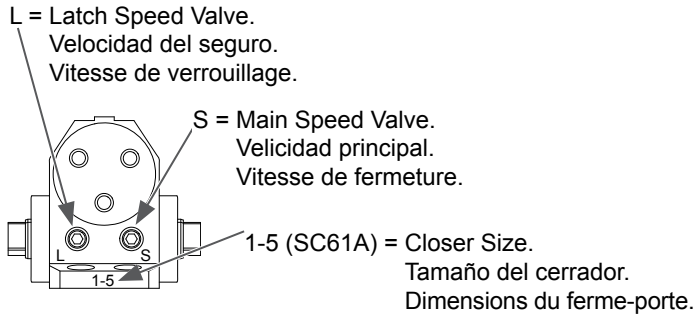

Parallel Arm Installation Instalación "brazo paralelo" Installation "bras parallèle"

Closer mounted on the push side of the door (opposite of the hinge side).

Cerrador montado al lado del empuje de la puerta (opuesto al lado del gozne).

Ferme-porte installé sur le côté à pousser de la porte (à l'opposé du côté de la charnière).

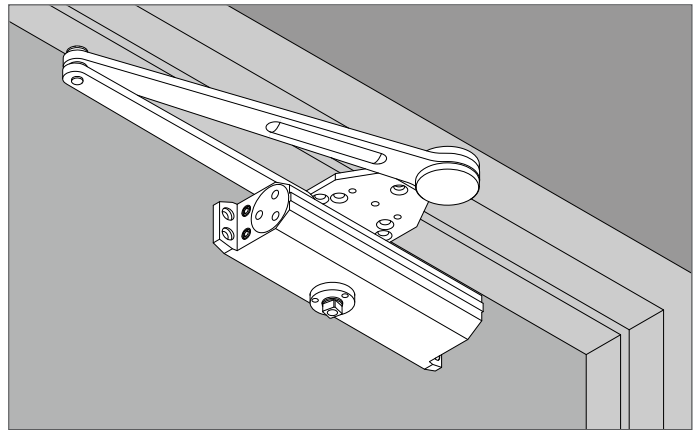

	Fasteners	Door Frame	Drill Sizes
Arm	#14 Wood	Wood	1/8"
	1/4-20 Machine	Metal	Drill: #7 Tap: 1/4-20
Closer Body	#14 Wood	Wood	1/8"
	1/4-20 Machine	Metal	Drill: #7 Tap: 1/4-20
	Self-Reaming, & Tapping (SRT)	Metal	1/8"
Either	Thru-Bolt	All	3/8"
Fifth Hole Spacer	#14 Wood	Wood	1/8"
	1/4-20 Machine	Metal	Drill: #7 Tap: 1/4-20
	Self-Reaming, & Tapping (SRT)	Metal	1/8"

CAUTION

Improper installation or regulation may result in personal injury or property damage. Follow all instructions carefully. For questions, call Falcon at 1-877-671-7011

ADVERTENCIA

Una instalación o un ajuste incorrectos pueden resultar en daño personal o material. Siga bien todas las instrucciones. Para más informaciones, llama a Falcon al 1-877-671-7011

DANGER

Une installation ou un réglage inadéquats peuvent entraîner des blessures ou des dommages. Veuillez suivre toutes les instructions avec soin. Pour plus de renseignements, composez le 1-877-671-7011

Customer Service

1-877-671-7011

www.allegion.com/us



© Allegion 2016
Printed in U.S.A.
44036 Rev. 11/16-a

1 Door and frame preparation.
Preparación de la puerta y el marco.
Préparation de la porte et du cadre.

- A. Choose degree of door opening. B. Drill per screw chart. (See front page)
A. Elija el grado de apertura de la puerta. B. Barrene según el gráfico. (Vea la página de la cubierta)
A. Sélectionnez le degré d'ouverture désiré. B. Percez selon les indications du tableau. (voir la page frontispice)

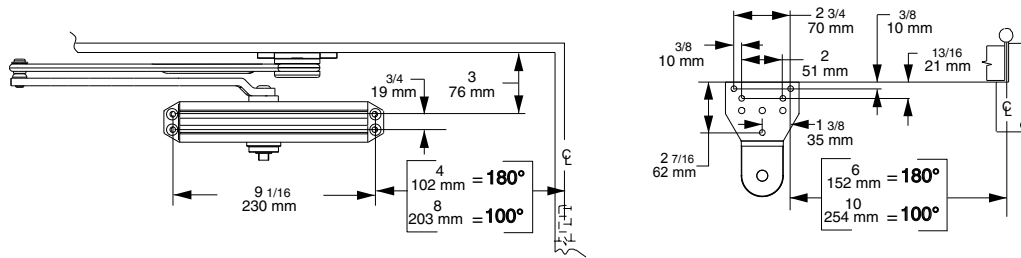

Right hand door illustrated. Same dimensions apply for left hand door measured from hinge side.
Montaje de puerta a la derecha como ilustrado. Las mismas dimensiones se aplican para un montaje de puerta a la izquierda medidas a partir del lado del gozne.
Porte main droite illustrée. Les mêmes dimensions s'appliquent pour une porte main gauche mesurées à partir du côté de la charnière.

2 Determine door width, adjust spring power to match chart.
Determina la anchura de la puerta. Ajuste la potencia del resorte según lo indicado en el gráfico.
Mesurez la largeur de la porte. Réglez le ressort selon les indications du tableau.

	POWER ADJUSTMENT AJUSTE DE POTENCIA REGLER LA PUISSANCE
	SC61A (1-5)
	-12
32" - 813 mm	-6
36" - 914 mm	0
42" - 1067 mm	+6
48" - 1219 mm	+13

3 Disconnect arm & shoe assembly from main arm.
Desconecte el ensamblaje del brazo y de la zapata del brazo principal.
Séparez l'assemblage du bras et de la console du bras principal.

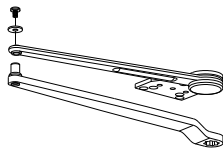

4 Install arm & shoe assembly onto frame.
Instale el ensamblaje del brazo y de la zapata en el cuadro.
Installez l'assemblage du bras et de la console sur le cadre.

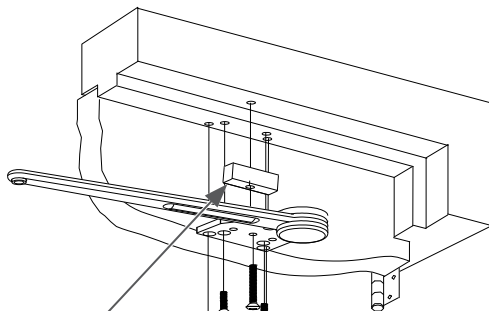

Fifth hole spacer.
Espaciador para el quinto agujero.
Espaceur du cinquième trou.

5 Install closer onto door.
Monte el cerrador en la puerta.
Installez le ferme-porte sur la porte.

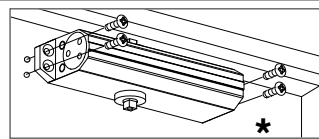

- * BC faces toward the hinge edge.
- * BC da cara al borde del gozne.
- * BC fait face au bord de la charnière.

6 Attach main arm to closer.
Coloque el brazo principal al cerrador.
Attachez le bras principal au ferme-porte.

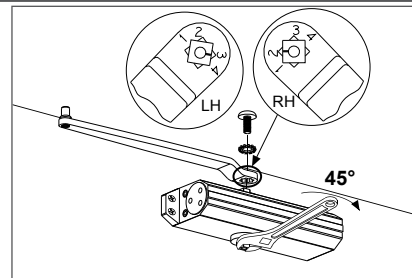

7 Connect arm pieces.
Conecte las partes del brazo.
Réunissez les sections de bras.

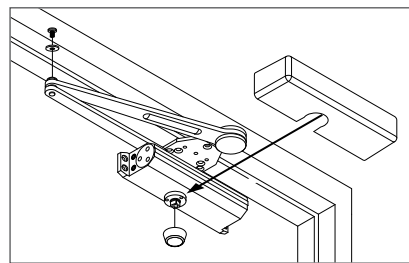

Screw cap onto shaft and install cover.
Atornille la tapa en el eje e instale la cubierta.
Tournez le capuchon sur l'arbre et installez le couvercle.

8 Adjustment instructions.
Instrucciones de ajuste.
Instructions de réglage.

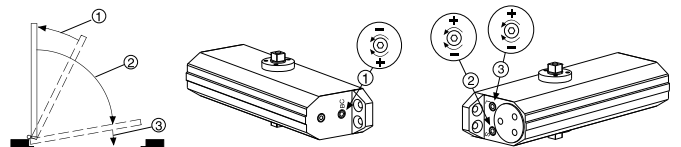

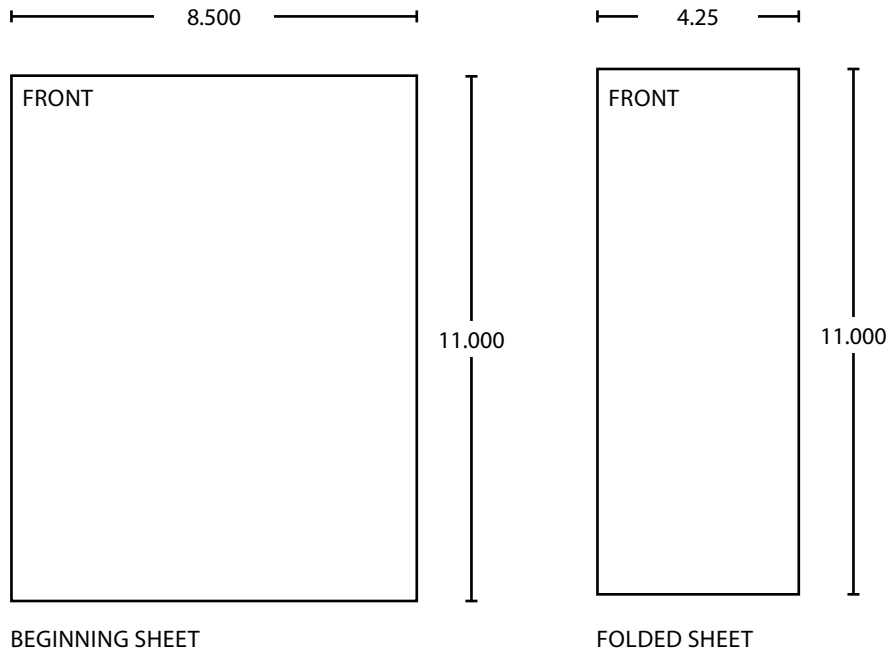

Additional Notes:
1. None

Revision History						Revision Description:					
A	B	C	D	E	F	N/A					
xxxxx											
Material						Edited By		Approved By		EC Number	Release Date
White Paper						N. Wilson		M. Roberts		xxxxx	11-09-16
Notes						Title					
1. printed two sides						SC60 Series Heavy Duty Instruction Sheet					
2. printed black						Creation Date		Number		Revision	
3. tolerance ± .13						08-08-2016		44036		A	
4. printed in country may vary						Created By		Activity		© Allegion 2016	
5. drawings not to scale						N. Wilson		3899 Hancock Expwy Security, CO 80911			
						Software: InDesign CS6					