



D-1504

FALCON®

## F-XX-C-WDC & XX-C-WDC EXIT DEVICES

### INSTALLATION INSTRUCTIONS

# 8 REVERSING INSTRUCTIONS

## TO REVERSE THE HANDING OF A (F)XX-C-WDC DEVICE

NOTE: TO REVERSE TRIM, REFER TO SEPARATE INSTALLATION SHEETS.



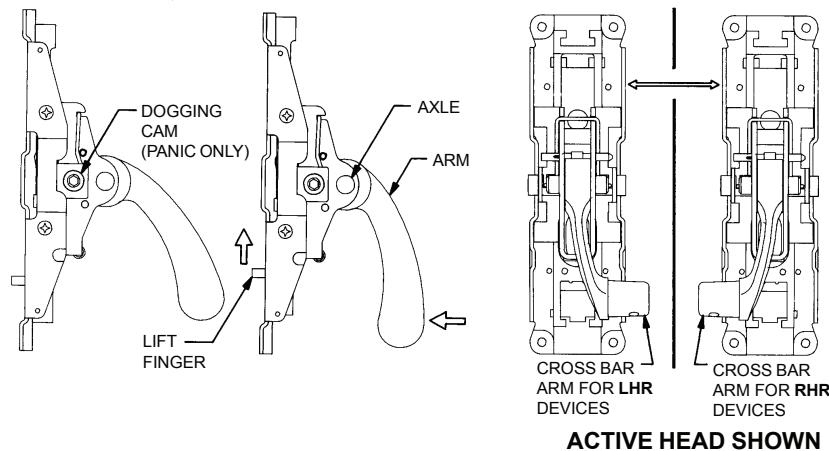







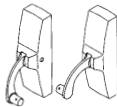
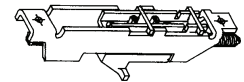
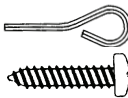

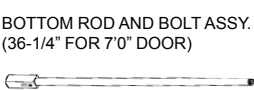

1. REMOVE FOUR SCREWS (NOT SHOWN) AND CHASSIS COVER FROM BOTH ACTIVE AND INACTIVE HEADS.
2. SLIDE CHASSIS COVERS BACK AND REMOVE AXLE FROM CROSS BAR ARM.
3. REMOVE CHASSIS COVERS FROM HEADS.
4. SWITCH ARMS FROM ACTIVE TO INACTIVE HEADS.
5. RE-INSTALL AXLE THRU HEADS AND CROSS BAR ARMS.
6. CHECK FOR PROPER FUNCTION.
7. PROCEED WITH DEVICE INSTALLATION.

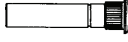
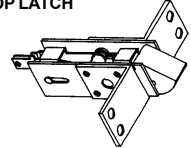
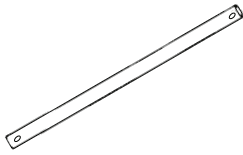
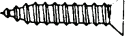

# 1 PARTS CHECK

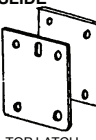
- 1) MAKE SURE THE CORRECT DEVICE IS BEING USED AND IS THE CORRECT HANDING.  
(SEE PAGE 12 FOR REVERSING INSTRUCTIONS.)
- 2) MAKE SURE ALL NEEDED PARTS ARE ON HAND.

NOTE: LIST DOES NOT REFLECT ALL POSSIBLE APPLICATIONS

<b>1. (F) XX-C-WDC DEVICE</b>  NOTE: DEVICE IS FIELD REVERSIBLE	<b>5. CENTERSLIDE</b> 	<b>8. SCREW PACK</b> DOGGING KEY (1 QTY) PANIC ONLY  #10x1-1/4" PPHSMS (8 QTY) 
<b>2. STRIKES</b> 4188 TOP STRIKE  2130 BOTTOM STRIKE 	<b>6. VERTICAL RODS</b> TOP ROD (37-1/4" FOR 7'0" DOOR)  BOTTOM ROD AND BOLT ASSY. (36-1/4" FOR 7'0" DOOR) 	#10-24x3/4" FPHMS (4 QTY)  #8-32x3/8" UFPHMS (2 QTY)  SEX BOLT (6 QTY) 1/4"-20 THREAD 
<b>3. TOP LATCH</b> 	<b>7. CROSSBAR</b> 	#10x1-1/4" FPHSMS (9 QTY)  1/4" C'SK FINISH WASHER (4 QTY)  1/4"-20x3/4" FPHMS (4 QTY) 
<b>4. TOP LATCH REINFORCING PLATES &amp; CENTERSLIDE MOUNTING PLATE</b> CENTERSLIDE MOUNTING PLATE  TOP LATCH REINFORCING PLATES 		SPECIAL SCREW (P/N 4836 - 2 QTY)  BOTTOM BOLT GUIDE (1 QTY)  COTTER KEY (1 QTY)  RELEASE BRACKET (1 QTY) 

- 3) MAKE SURE OUTSIDE TRIM (IF BEING USED) HAS BEEN PROVIDED AND IS THE CORRECT HANDING.  
NOTE: L-CONTROL OR SE-CONTROL TRIMS CANNOT BE REVERSED

## 2 DOOR LAYOUT

**NOTE: FOR FACTORY PREPARED DOORS, VERIFY LAYOUT.**

- 1) DOOR MUST BE FITTED AND HUNG PROPERLY BEFORE PROCEEDING.
- 2) MARK VERTICAL  $\zeta$ , DEVICE REF.  $\zeta$  AND HORIZONTAL  $\zeta$  ON DOOR AND FRAME. (SEE FIGURES AND CHART BELOW)

A. VERTICAL  $\zeta$ .

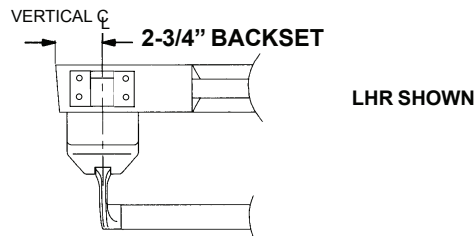

B. DEVICE REF.  $\zeta$  AND HORIZONTAL  $\zeta$ .

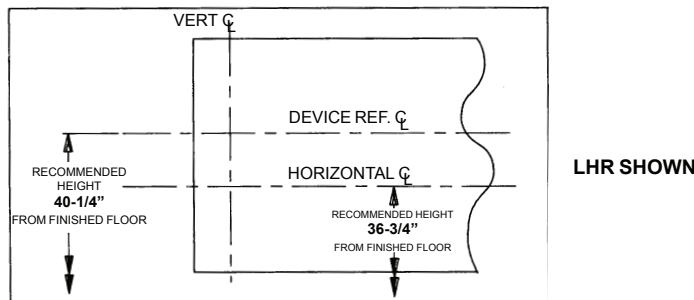

- 3) MARK LOCATION OF RELEASE BRACKET ACCESS HOLE ON VERTICAL  $\zeta$  AT TOP OF DOOR AS SHOWN BELOW.

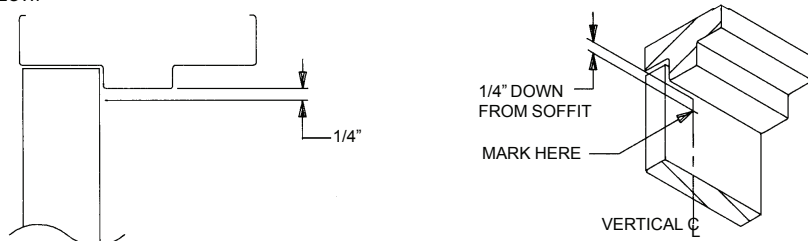

PAGE 2

## 7 ADJUSTMENT

- 1) WITH THE LATCH BOLT PROJECTED, **SLOWLY** DEPRESS CROSS BAR. TOP LATCH BOLT SHOULD REMAIN IN RETRACTED POSITION. IF NOT, TURN TOP ADJUSTMENT PIN COUNTER CLOCKWISE BY 1/2 TURN AND **SLOWLY** PUSH CROSS BAR, TOP LATCH BOLT SHOULD REMAIN IN RETRACTED POSITION. IF NOT, REPEAT THIS PROCESS UNTIL TOP LATCH BOLT REMAINS RETRACTED.

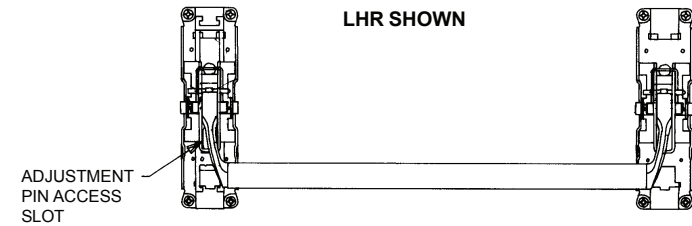

- 2) RELEASE TOP LATCH BOLT USING TOOL. OPERATE DEVICE SEVERAL TIMES TO CHECK ADJUSTMENT BY **SLOWLY** PUSHING ON CROSS BAR, CHECKING TOP LATCH BOLT RETRACTION, AND THEN RELEASING THE TOP LATCH BOLT EACH TIME.
- 3) CHECK DOGGING OPERATION (PANIC APPLICATION ONLY)
  - A) PUSH CROSS BAR, THEN INSERT AND TURN DOGGING KEY CLOCKWISE. IF YOU CANNOT TURN DOGGING KEY WHILE PUSHING CROSS BAR, REDUCE THE TOP LATCH BOLT PROJECTION BY USING THE ADJUSTMENT PINS IN THE CENTERSLIDE (REFER TO STEP 1 ABOVE AND PAGE 7, STEP 2B). REPEAT UNTIL CROSS BAR IS DOGGED AND LATCHES ARE HELD RETRACTED.
  - B) AFTER REMOVING THE DOGGING KEY, THE CROSS BAR SHOULD REMAIN RETRACTED.
  - C) RE-INSERT THE DOGGING KEY AND TURN IN OPPOSITE DIRECTION. CROSS BAR WILL "POP OUT"
  - D) FOR CYLINDER DOGGING, REFER TO INSTRUCTION D-4085.
- 4) MARK, DRILL AND INSTALL BOTTOM STRIKE, REFER TO DRILLING TEMPLATE.
- 5) RELEASE TOP LATCH USING TOOL. CHECK ENGAGEMENT BETWEEN BOTTOM BOLT AND BOTTOM STRIKE. ADJUST BOTTOM BOLT PROJECTION IF REQUIRED (REFER TO PAGE 9, STEP 7 AND PAGE 7, STEP 2B).
- 6) INSTALL RELEASE BRACKET, REFER TO DRILLING TEMPLATE. ALLOW DOOR TO CLOSE TO SEE IF THE PLUNGER WILL RELEASE THE TOP LATCH BOLT. IF THE PLUNGER STOPS THE DOOR FROM SWINGING TO THE DOOR STOP, ADJUST THE PLUNGER IN USING AN ALLEN WRENCH; IF THE TOP LATCH BOLT DOES NOT RELEASE, ADJUST THE PLUNGER OUT.
- 7) CHECK DEVICE FOR SMOOTH OPERATION AND LATCH BOLT ENGAGEMENT.
- 8) RE-INSTALL CHASSIS COVER.
  - A) REMOVE AXLES FROM BOTH ACTIVE AND INACTIVE CHASSIS.
  - B) REMOVE CROSSBAR AND CROSSBAR ARMS FROM BOTH CHASSIS.
  - C) SLIDE CROSSBAR ARMS INTO RECTANGULAR CUT-OUT IN TOP OF CHASSIS COVER.
 

**NOTE: THE 1/2" DIA. HOLE IN THE CHASSIS COVER ON BOTH COVERS SHOULD FACE EACH OTHER.**
  - D) INSERT CROSSBAR ARMS INTO CHASSIS AND INSERT AXLES.
  - E) SLIDE CHASSIS COVER OVER CHASSIS AND ATTACH WITH 4 (PER HEAD) #8-32x1/4" UFPHMS.

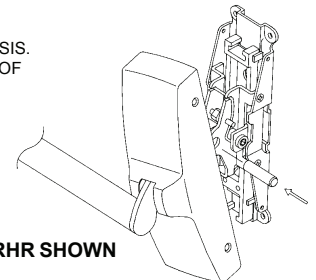

PAGE 11

- 17) INSERT A TOOL INTO THE RELEASE BRACKET ACCESS HOLE AND PUSH THE TOP LATCH BOLT RETAINER. THE LATCH BOLT SHOULD RELEASE, PULL DOWN ON THE LIFT TAB AND THE LATCHBOLT SHOULD GO INTO THE FULLY PROJECTED POSITION.
- 18) REPEAT STEPS 15 THRU 17 SEVERAL TIMES, CHECKING FOR BINDS OR ROUGH ACTION IN THE CENTERSLIDE AND TOP LATCH.
- 19) RE-HANG THE DOOR IN THE OPENING

## 6 DEVICE AND STRIKE INSTALLATION

- 1) SURFACE MOUNT DEVICE USING FOUR #10x1-1/4" PPHSMS (OR MOUNT TO SEXBOLTS USING #10-24x3/4" PPHMS) NOTING THE ALIGNMENT BETWEEN THE LIFT FINGER ON THE DEVICE HEAD AND THE LIFT TAB ON THE CONCEALED CENTERSLIDE (SEE BELOW).

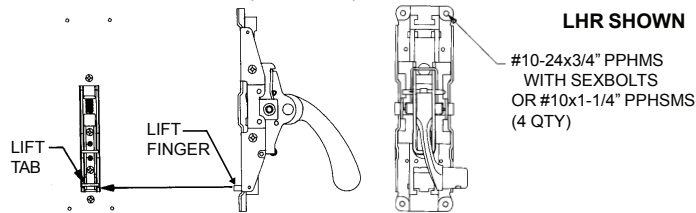

- 2) REMOVE CROSSBAR RETAINER SCREW AND ROUNDED WASHER FROM XX CROSSBAR ARMS. SLIDE THE CROSSBAR OVER BOTH THE ACTIVE AND INACTIVE ARMS AND ATTACH WITH CROSSBAR RETAINER SCREW AND ROUNDED WASHER.

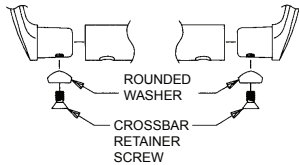

- 3) LOCATE, MARK AND DRILL INACTIVE HEAD MONTING HOLES.
  - A) LEVEL CROSSBAR ON DOOR AND MARK CENTER OF FOUR MOUNTING HOLES.
  - B) PREPARE HOLES FOR MOUNTING SCREWS:
    - FOR SHEET METAL SCREWS: DRILL 9/64" DIA. HOLES
    - FOR MACHINE SCREWS WITH SEXBOLTS: DRILL 7/32" DIA. HOLE THRU DOOR AND DRILL 3/8" DIA. HOLE ON OPPOSITE SIDE OF DOOR USING 7/32" DIA. HOLE AS PILOT.

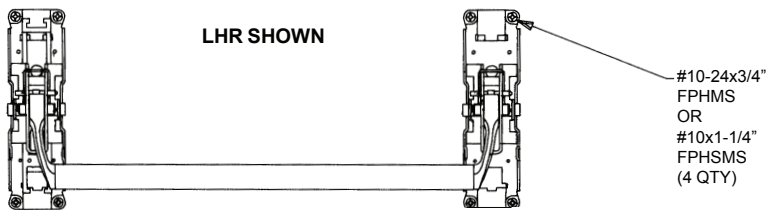

- 4) INSTALL TOP STRIKE USING TWO #10-24x3/4" FPHMS, REFER TO DRILLING TEMPLATE.

PAGE 10

## 3 DOOR & HARDWARE PREPARATION

- 1) REMOVE DOOR FROM OPENING AND LAY FLAT.
- 2) LAY OUT DRILLING TEMPLATES FROM INSIDE THIS BOOK ALONG HORIZONTAL AND VERTICAL CENTERLINES. CENTER PUNCH AND PREPARE HOLES AS SPECIFIED.
- 3) PREPARE DOOR FOR TOP LATCH, TOP LATCH REINFORCING PLATES AND BOTTOM BOLT GUIDE AS SHOWN ON DRILLING TEMPLATES.
- 4) PREPARE FRAME FOR TOP STRIKE PER DRILLING TEMPLATES.
- 5) DRILL 1/2" DIA. RELEASE BRACKET ACCESS HOLE AT LOCATION SPECIFIED ON PAGE 2, STEP 3.
- 6) IF USING OUTSIDE TRIM, PREPARE TRIM SIDE OF DOOR USING SEPARATE TRIM DIRECTION SHEET. FOR SEXBOLT INSTALLATIONS, PREPARE DOOR AS SHOWN BELOW.

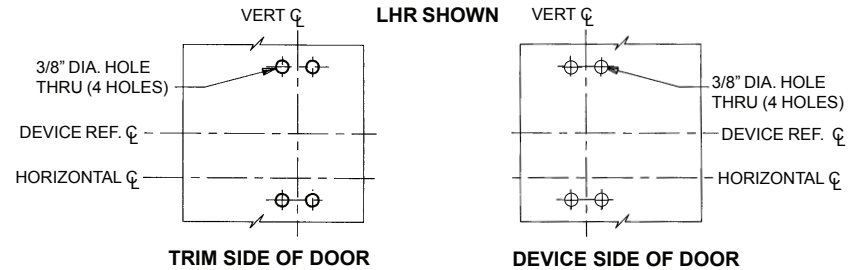

- 7) DETERMINE CROSSBAR LENGTH.
  - A. MEASURE DISTANCE BETWEEN VERTICAL  $\zeta$  AND EDGE OF DOOR (DIMENSION "Y" BELOW).
  - B. CALCULATE CROSSBAR LENGTH "X" USING FORMULA BELOW:

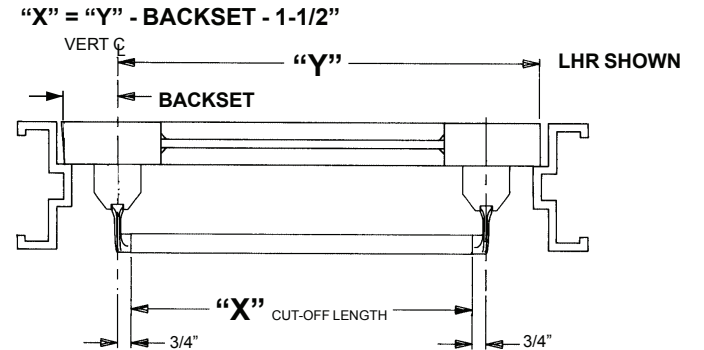

PAGE 3

- 8) IF CROSSBAR IS LONGER THAN "X", CUT THE DEVICE.  
A. MARK CROSSBAR TO LENGTH "X".

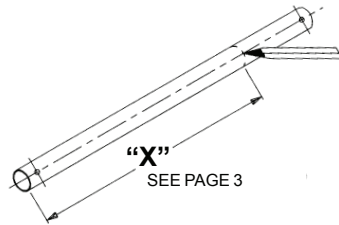

- B. CUT CROSSBAR TO MARKED DIMENSION AND REMOVE BURRS.

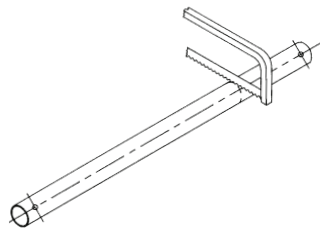

**NOTE: FACTORY RECOMMENDS SAWING RATHER THAN CUT GRIND TO SIZE. GRINDING CAN DAMAGE THE FINISH OF THE DEVICE AND SAWING RESULTS IN LESS DAMAGE TO THE DEVICE'S FINISH.**

- C. DRILL A 5/16" DIA. HOLE 5/8" FROM THE JUST CUT END OF THE CROSSBAR.

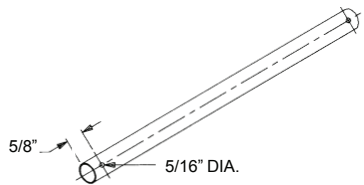

- 9) IF DOOR OPENING IS NOT 7'0", DETERMINE TOP ROD LENGTH BASED ON A 40-1/4" DEVICE REF. CL FROM THE FINISHED FLOOR.

- A. FOR DOOR OPENINGS UNDER 7'0":

1. SUBTRACT DOOR OPENING FROM 7'0".
2. SUBTRACT ANSWER FROM PREVIOUS STEP FROM 37-1/4" TO DETERMINE TOP ROD LENGTH.  
(EXAMPLE: 6'8" OPENING: 7'0" - 6'8" = 4"; 37-1/4" - 4" = 33-1/4" TOP ROD)

- B. FOR DOOR OPENINGS OVER 7'0":

1. SUBTRACT 7'0" FROM DOOR OPENING.
2. ADD ANSWER FROM PREVIOUS STEP TO 37-1/4" TO DETERMINE TOP ROD LENGTH.  
(EXAMPLE: 8'10" OPENING: 8'10" - 7'0" = 22"; 37-1/4" + 22" = 59-1/4" TOP ROD)

- 13) WITH THE TOP LATCH PROJECTED, TURN THE TOP ADJUSTMENT PIN CLOCKWISE (MOVING THE LIFT TAB TOWARDS THE TOP LATCH) OR COUNTER-CLOCKWISE (MOVING THE LIFT TAB TOWARDS THE BOTTOM OF THE DOOR) UNTIL THE LIFT TAB IS POSITIONED LIKE THIS.

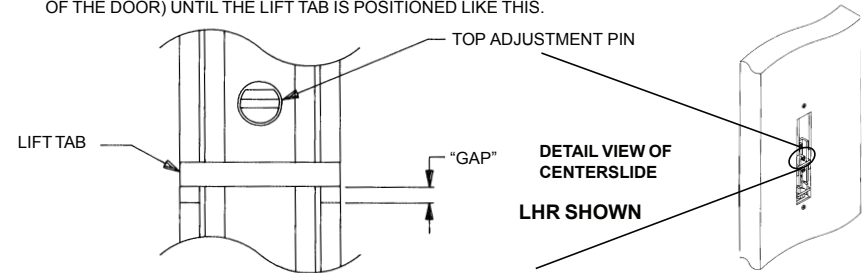

- 14) TURN THE TOP ADJUSTMENT PIN COUNTER-CLOCKWISE UNTIL THE LIFT TAB MOVES TOWARDS THE BOTTOM OF THE DOOR AND CLOSES THE "GAP".

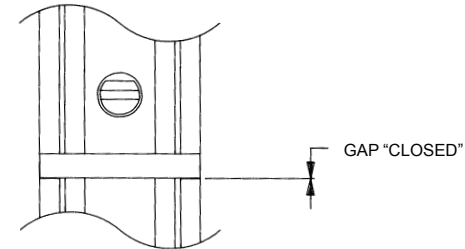

- 15) LIFT UP ON THE LIFT TAB UNTIL THE TOP LATCH BOLT IS FULLY RETRACTED. THEN, ATTEMPT TO SLIDE THE CENTERSLIDE THE OPPOSITE DIRECTION, THE CENTERSLIDE SHOULD NOT MOVE AND THE TOP LATCH BOLT SHOULD REMAIN IN THE RETRACTED POSITION. IF NOT, TURN THE TOP ADJUSTMENT PIN ONE QUARTER TURN COUNTER-CLOCKWISE AND TRY AGAIN. REPEAT UNTIL THE TOP LATCH BOLT REMAINS RETRACTED.

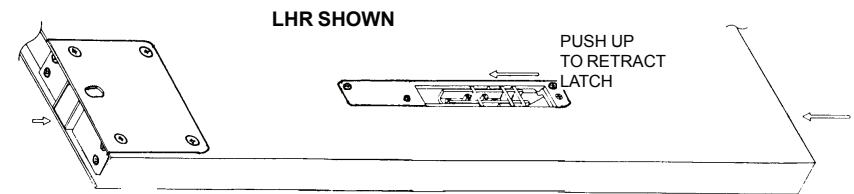

- 16) CHECK THE PROJECT ON OF THE BOTTOM BOLT. WITH THE TOP LATCH BOLT RETRACTED THE BOTTOM BOLT SHOULD NOT BE PROJECTING FROM THE BOTTOM OF THE DOOR, BUT SHOULD STILL BE HELD BY THE BOTTOM BOLT GUIDE. IF THE BOLT IS PROJECTING FROM THE DOOR, TURN THE BOTTOM ADJUSTMENT SCREW CLOCKWISE; IF IT IS INSIDE THE DOOR, LINE UP THE BOTTOM BOLT WITH THE BOLT GUIDE AND TURN THE BOTTOM ADJUSTMENT SCREW COUNTER-CLOCKWISE.

# 5 CONCEALED VERTICAL ROD ASSEMBLY INSTRUCTION

- 1) INSTALL TOP LATCH REINFORCING PLATES WITH 1/4"-20x3/4" FPHMS, 1/4" FINISH WASHER AND SEX BOLTS. BE SURE THAT THE TOP LATCH REINFORCING PLATE WITH THE OVAL CUT-OUT, AS WELL AS THE FINISH WASHERS, ARE ON THE INTERIOR SIDE OF THE DOOR.
- 2) LAY CENTERSLIDE ASSEMBLY INTO CENTERSLIDE PREP AREA OF DOOR. SHIFT UNIT UP (INSIDE OF DOOR) UNTIL IT WILL NOT GO ANY FURTHER.
- 3) SLIDE IN BOTTOM ROD AND BOLT ASSEMBLY FROM BOTTOM OF DOOR UNTIL IT CONTACTS CENTERSLIDE SCREW.
- 4) CHECK ALIGNMENT OF BOTTOM ROD AND BOLT ASSEMBLY TO CENTERSLIDE CONNECTOR SCREW. ALIGNED, TURN ADJUSTMENT SCREW FOR BOTTOM ROD ADJUSTMENT CLOCKWISE, WHICH WILL THREAD THE BOTTOM ROD AND BOLT ASSEMBLY ONTO THE CENTERSLIDE SCREW. TURN THE ADJUSTMENT SCREW ABOUT 10 TURNS.
- 5) SHIFT CENTERSLIDE & BOTTOM ROD AND BOLT ASSEMBLY TO THE BOTTOM OF THE CENTERSLIDE PREP UNTIL IT WILL NOT GO ANY FURTHER.
- 6) CONNECT TOP LATCH TO TOP ROD USING COTTER KEY. SECURE ASSEMBLY BY BENDING COTTER KEY.
- 7) SLIDE IN TOP LATCH & TOP ROD ASSEMBLY FROM TOP OF DOOR UNTIL IT CONTACTS CENTERSLIDE SCREW.
- 8) CHECK ALIGNMENT OF TOP LATCH & TOP ROD ASSEMBLY TO CENTERSLIDE CONNECTOR SCREW. WHEN PROPERLY ALIGNED, TURN ADJUSTMENT SCREW FOR TOP ROD ADJUSTMENT CLOCKWISE, WHICH WILL THREAD THE TOP LATCH & TOP ROD ASSEMBLY ONTO THE CENTERSLIDE SCREW. TURN THE ADJUSTMENT SCREW ABOUT 10 TURNS.

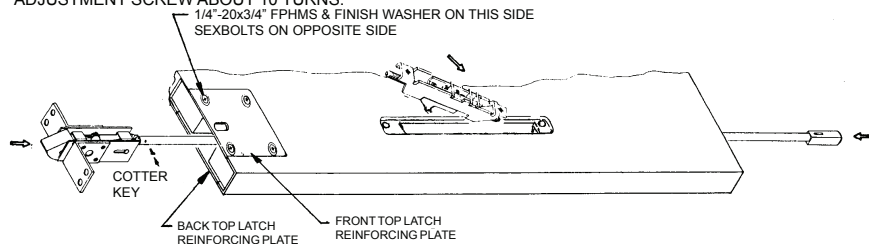

- 9) INSTALL CENTERSLIDE TO CENTERSLIDE MOUNTING PLATE WITH #8-32x3/8" UFPHMS.
- 10) IF USING OUTSIDE TRIM, INSTALL PER SEPARATE DIRECTIONS; OTHERWISE, INSERT SEXBOLTS INTO INTO 3/8" DIA. HOLES. THRU-BOLT CENTERSLIDE MOUNTING PLATE TO TRIM OR SEXBOLTS USING SPECIAL SCREW (P/N 4836).
- 11) TURN TOP ADJUSTMENT SCREW UNTIL TOP LATCH IS SEATED INTO TOP PREP.
- 12) INSTALL TOP LATCH AND BOTTOM BOLT GUIDE USING #10x1-1/4" FPHSMS (4 FOR TOP LATCH, 5 FOR BOTTOM BOLT GUIDE).

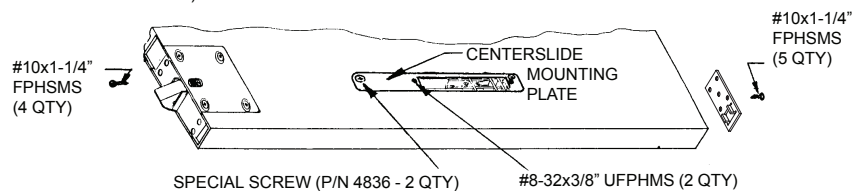

- 10) MODIFY TOP ROD TO REQUIRED LENGTH.
  - A. FOR TOP RODS THAT ARE TOO LONG, FOLLOW PROCEDURE BELOW TO CUT ROD TO SIZE.
    1. MARK ROD TO REQUIRED LENGTH.
 

NOTE: ROD MUST BE MEASURED FROM THREADED PORTION OF ROD.

**DO NOT CUT ROD AT END WITH INTERNAL THREADS.**

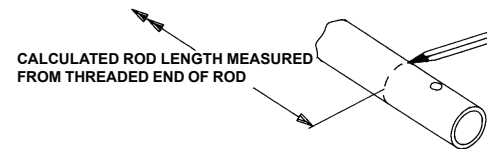

2. CUT ROD AT MARKED LOCATION.

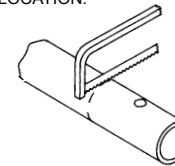

3. DRILL COTTER KEY CONNECTION HOLE. DRILL 1/8" DIA. HOLE THRU ON VERTICAL ROD 7/16" FROM END OF ROD JUST CUT.

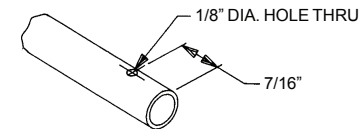

- B. FOR TOP RODS THAT ARE TOO SHORT, FOLLOW PROCEDURE BELOW:
  1. ATTACH EXTENSION RODS TO THREADED SECTION OF TOP ROD.



2. CHECK TOP ROD AND EXTENSION ROD ASSEMBLY FOR STRAIGHTNESS.
3. FOLLOW INSTRUCTIONS TO MARK, CUT AND DRILL TOP ROD (SEE ABOVE).

# 4 OPERATIONAL REVIEW

## 1) TOP LATCH FUNCTION.

A. WITH THE LATCH BOLT RETRACTED, PULL DOWN ON THE ROD CONNECTOR. THE LATCH BOLT WILL REMAIN RETRACTED.

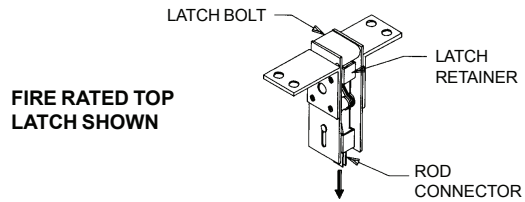

B. PULL DOWN ON THE ROD CONNECTOR AND PUSH ON THE LATCH RETAINER. THE LATCH BOLT WILL EXTEND.

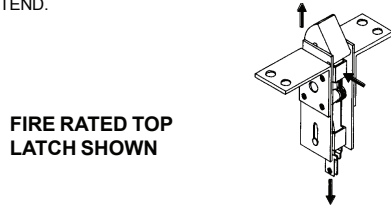

C. PUSH UP ON ROD CONNECTOR. THE LATCH BOLT WILL RETRACT AND REMAIN RETRACTED.

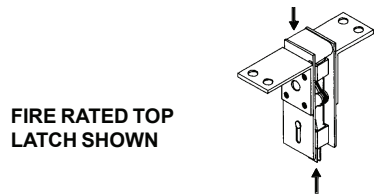

## 2. CENTERSLIDE FUNCTION.

A. PLACE THE CENTERSLIDE IN YOUR HAND. LIFT UP ON THE LIFT TAB TO CHECK IF THE CENTERSLIDE CAN MOVE FREELY (AS SHOWN BELOW). ALSO, NOTE THE LOCATIONS SHOWN FOR DEVICE LIFTING AND TRIM LIFTING.

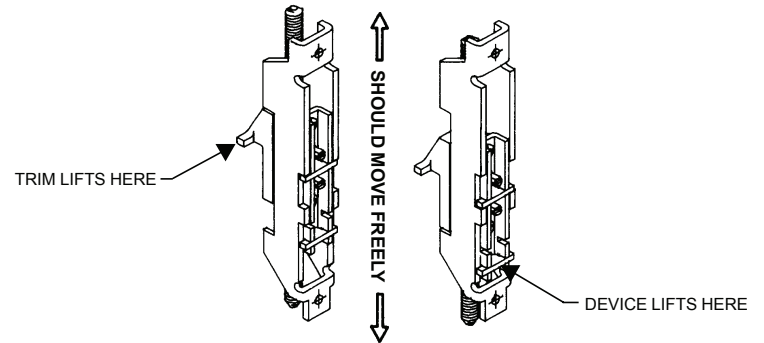

B. USING A SMALL FLAT-BLADE SCREW DRIVER, PUSH IN GENTLY ON THE TWO ADJUSTMENT PINS AND TURN. THE ROD CONNECTOR SCREW WILL ROTATE. (THIS IS THE VERTICAL ROD ADJUSTMENT FEATURE).

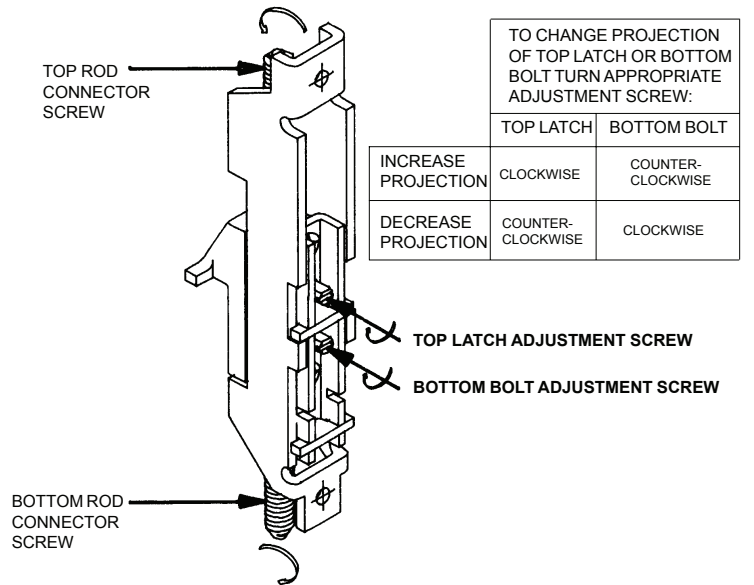

**XX SERIES WOOD DOOR  
 CONCEALED VERTICAL ROD  
 PANIC & 20 MINUTE FIRE  
 EXIT DEVICES**

**DRILLING TEMPLATE**

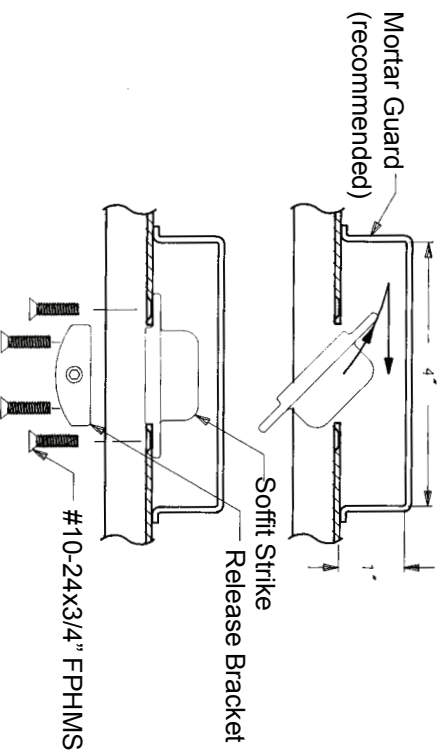
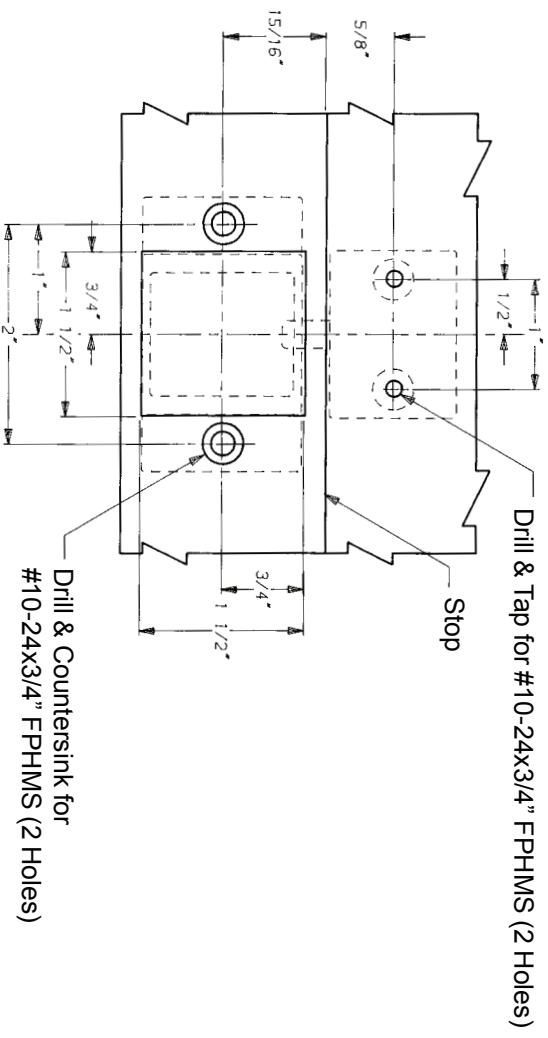

**BOTTOM STRIKE FLOOR CAVITY**

