

- ① A. INSTALL DOOR.
- B. MARK HORIZONTAL CENTERLINE ON DOOR AND EDGE OF DOOR.
- C. TAPE VERTICAL OR HORIZONTAL TEMPLATE TO THE DOOR (CHECK BACKSET).
- D. PREPARE DOOR FOR MOUNTING HOLES AS INDICATED ON TEMPLATE.

NOTES:

1. WOOD DOOR SHOWN.
2. FOR METAL DOORS USE #161 STANDARD CUTOUT.
3. THE 2 1/8" (54) HOLE CAN BE AS SMALL AS 1 1/16 (27) DIA.
4. LATCHES ARE NOT ADJUSTABLE FOR BEVELED EDGE DOORS.

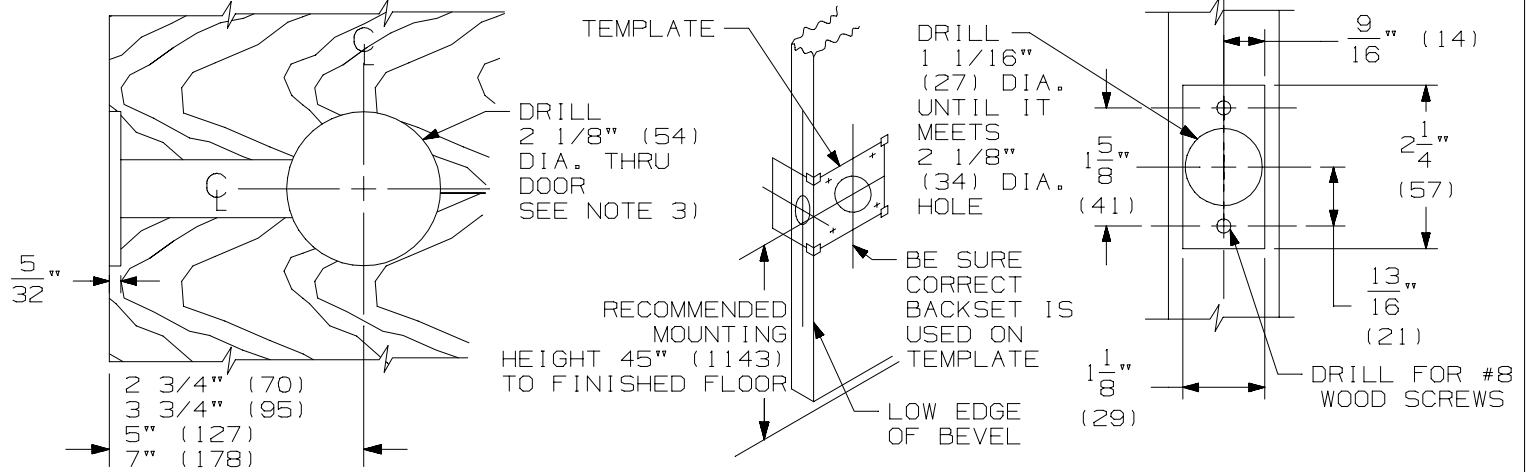

- ② A. SELECT STRIKE - STANDARD OR ASA.
- B. MARK CENTERLINE OF LATCH BOLT ON FRAME.
- C. CENTER STRIKE AND MARK SCREW LOCATIONS.
- D. MORTISE APPROPRIATE STRIKE DEPTH.
- E. INSTALL STRIKE.

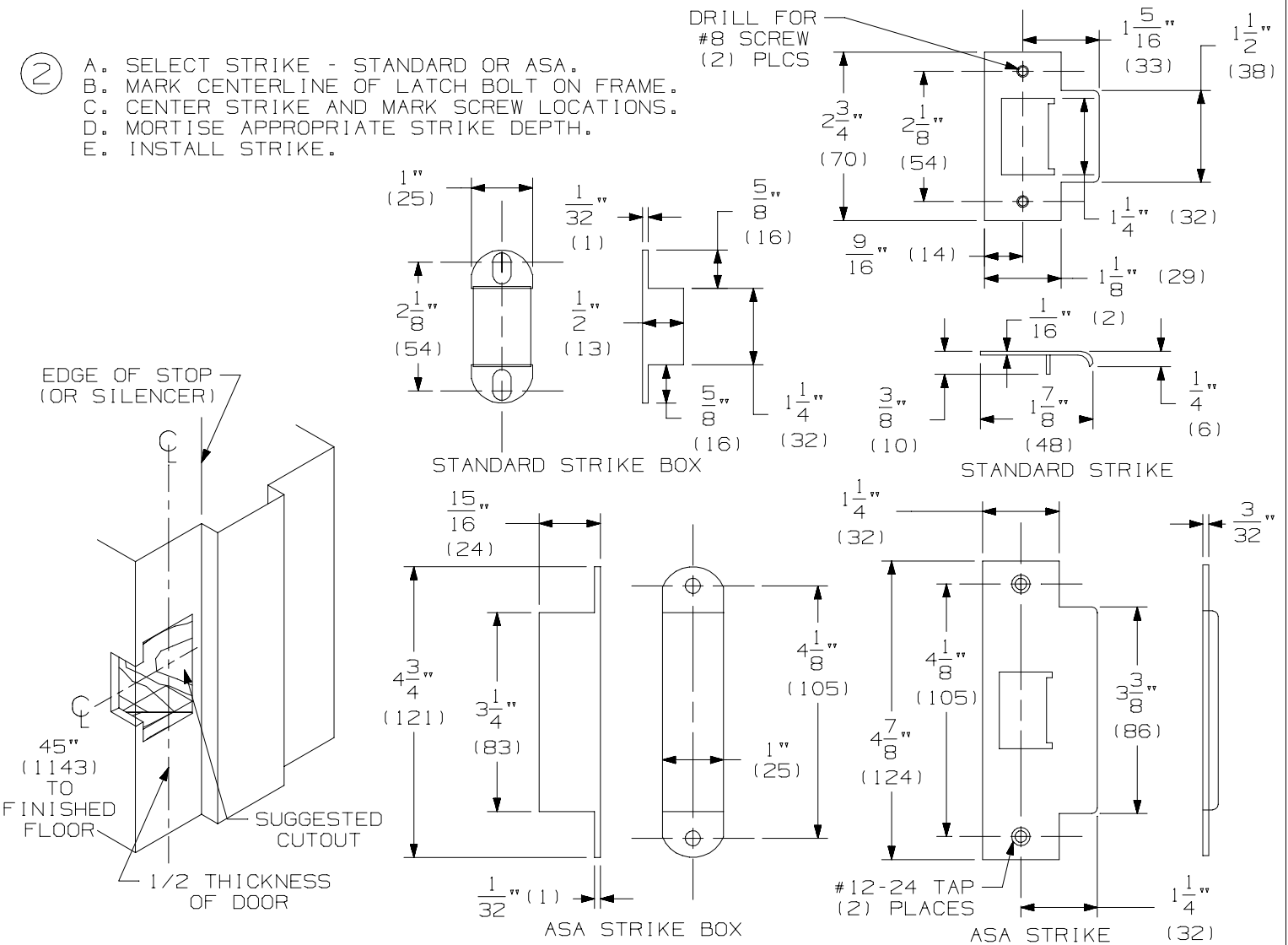

**GLYNN-JOHNSON**

**HL6 PUSH-PULL LATCH  
INSTALLATION TEMPLATE**



NOTE: DIMENSIONS IN ( ) ARE IN MILLIMETERS

TEMPLATE  
NUMBER:

INST.HL6\_B.PG1

DATE:  
05-29-15

3

- A. INSTALL LATCH BOLT ASSEMBLY WITH RADIUS SIDE OF LATCH BOLT ON THE PUSH SIDE OF DOOR.
- B. REMOVE COVERS FROM HANDLE ASSEMBLY.
- C. CHECK THE CAM POSITION ON THE PUSH HANDLE ASSEMBLY (SEE CHART).
- D. INSTALL PUSH HANDLE ASSEMBLY WITH LOCK SHAFT THRU LATCH BOLT ASSEMBLY.
- E. CHECK THE CAM POSITION ON THE PULL HANDLE ASSEMBLY (SEE CHART).
- F. INSTALL PULL HANDLE ASSEMBLY WITH LOCK SHAFT INSERTED INTO CAM.
- G. SECURE WITH SCREWS AND NUTS.
- H. INSTALL COVERS.

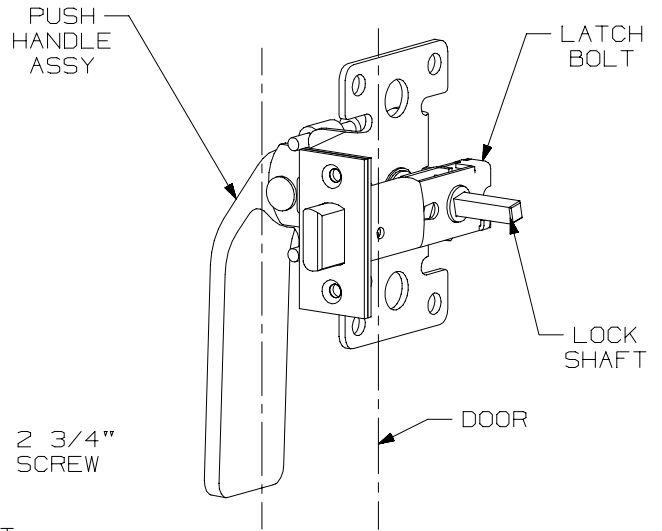
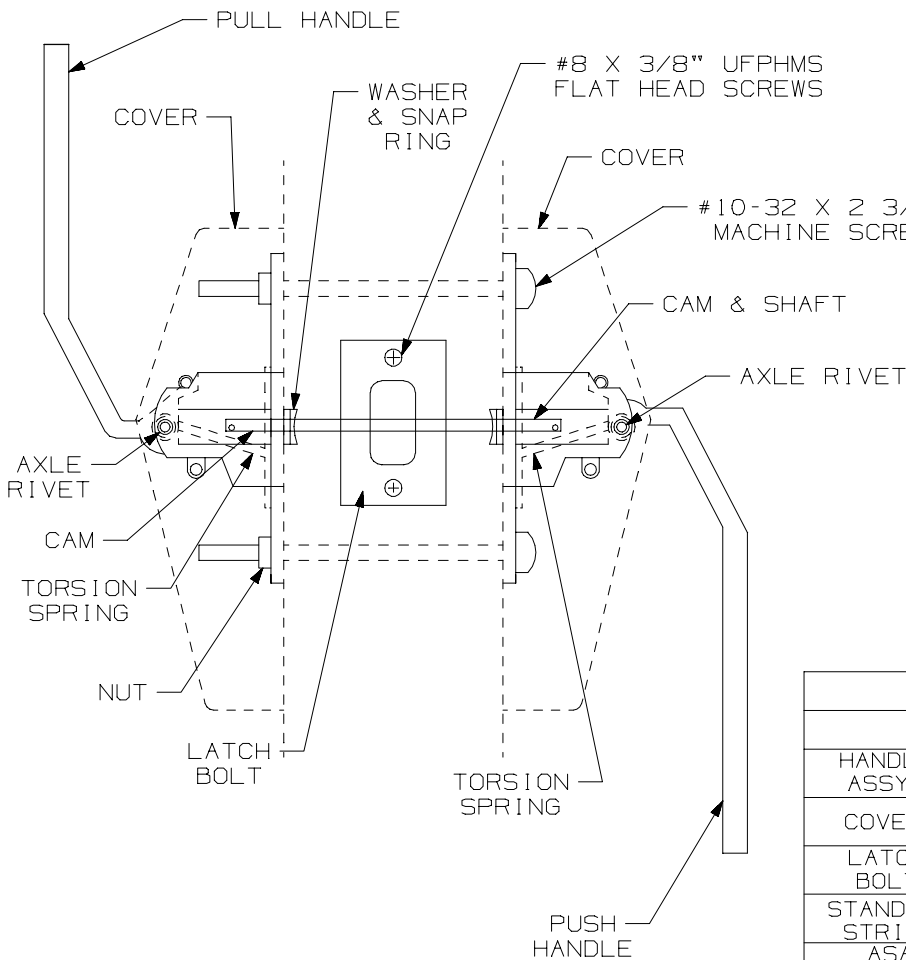
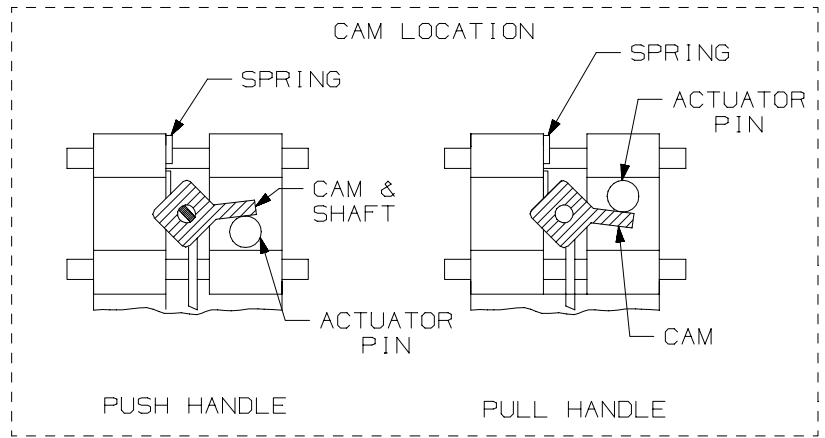

SCREW DETAILS			
	QTY.	WOOD	METAL
HANDLE ASSY.	4	10-32 x 2 3/4 PPHMS & NUTS	
COVER	4	6-32 x 1/4 UFPHMS	
LATCH BOLT	2	8 x 3/4 FPHSMS	8-32 x 3/4 UFPHMS
STANDARD STRIKE	2	8 x 3/4 FPHSMS	8-32 x 3/4 UFPHMS
ASA STRIKE	2	12 x 3/4 FPHSMS	12-24 x 1/2 UFPHMS

**GLYNN-JOHNSON**

**HL6 PUSH-PULL LATCH  
INSTALLATION TEMPLATE**



**ALLEGION**

NOTE: DIMENSIONS IN ( ) ARE IN MILLIMETERS

TEMPLATE  
NUMBER:

**INST.HL6\_B.PG2**

DATE:  
**05-29-15**