

TEMPLATE DRAWING

DWG. NO. 422 A

CATCH MOUNTED IN JAMB

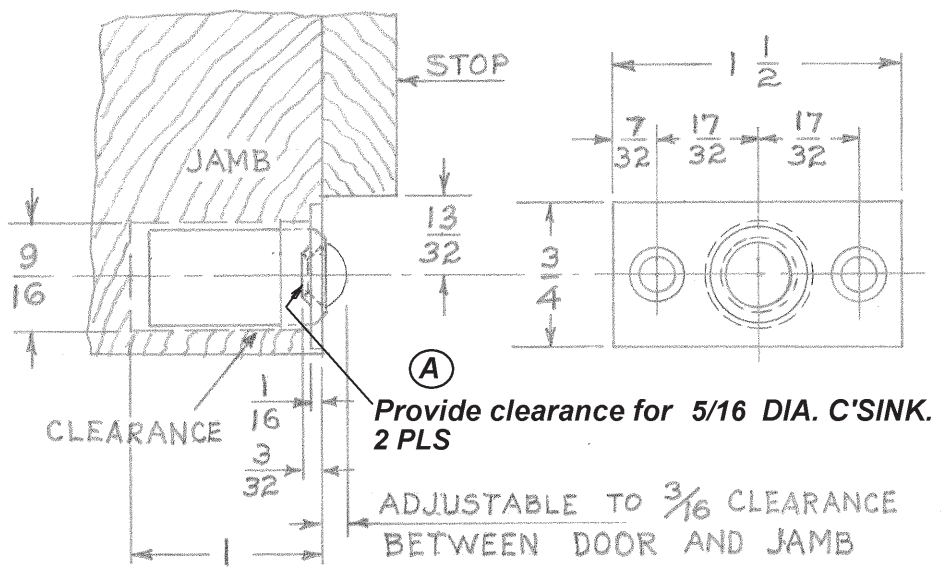

CATCH MOUNTED IN DOOR

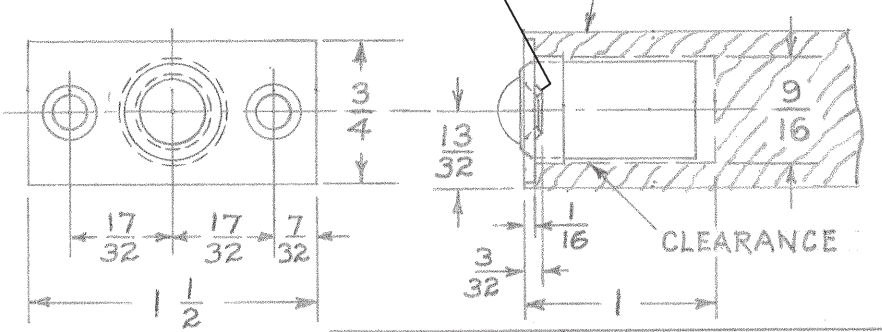
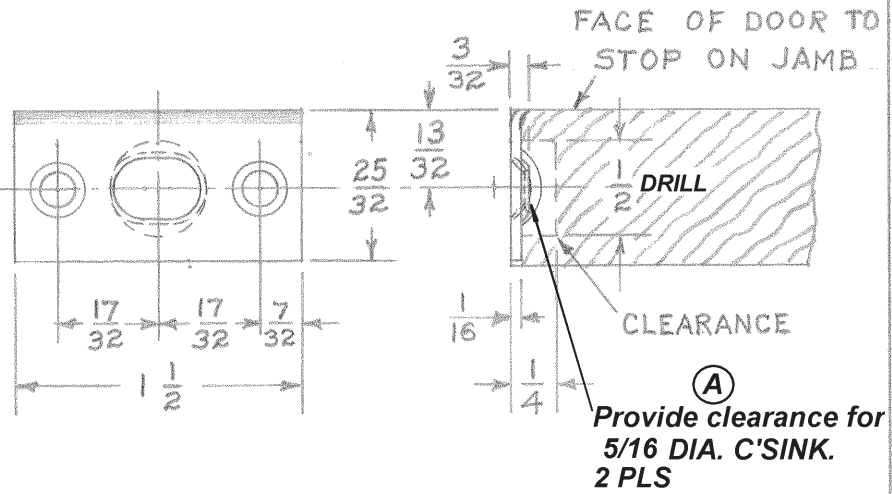
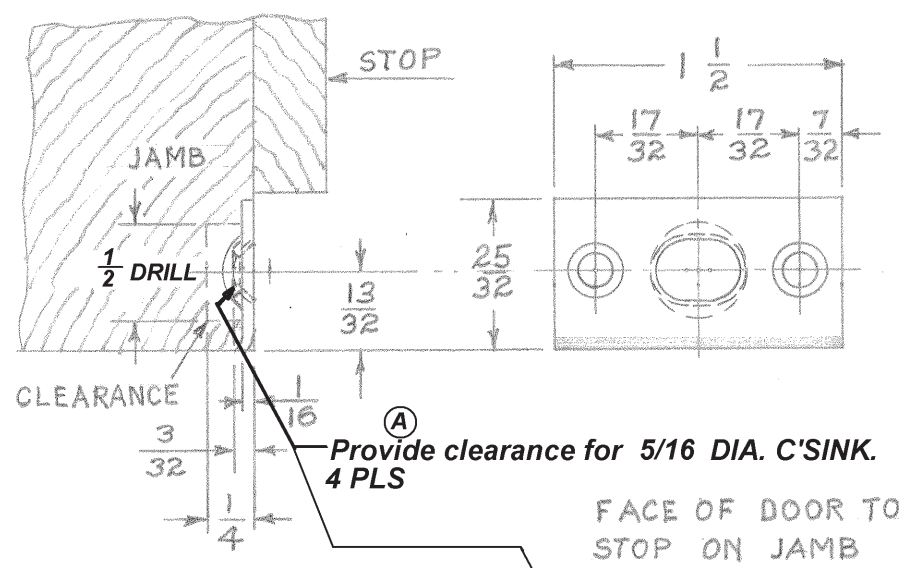

5/8 X 6 F.H. WOOD SCREWS

TEMPLATE 345 BALL CATCH

LETTER	CHANGE	DATE
A	ADDED NOTE "A" - ECO-03-13	4/10/03
B		
C		
F.C.B.	9-25-58	FULL SIZE

IVES DIVISION
LEIGH PRODUCTS, INC.
P. O. BOX 1887, NEW HAVEN, CONN. 06508