



829623-00

VR810/VR814 VANDAL RESISTANT TRIM

IVES®

Installation Instructions for use with XX and 18 Monarch rim and surface vertical exit devices

- 1** PREPARE PUSH SIDE OF DOOR FOR EXIT DEVICE. SEE EXIT DEVICE INSTRUCTIONS FOR PREPARATION.
- 2** PREPARE PULL SIDE OF DOOR FOR TRIM.
 - A** TRANSFER VERTICAL AND HORIZONTAL DEVICE CENTER LINES FROM PUSH SIDE OF DOOR TO PULL SIDE.
 - B** LOCATE AND PREPARE ALL HOLES AS INDICATED BELOW.

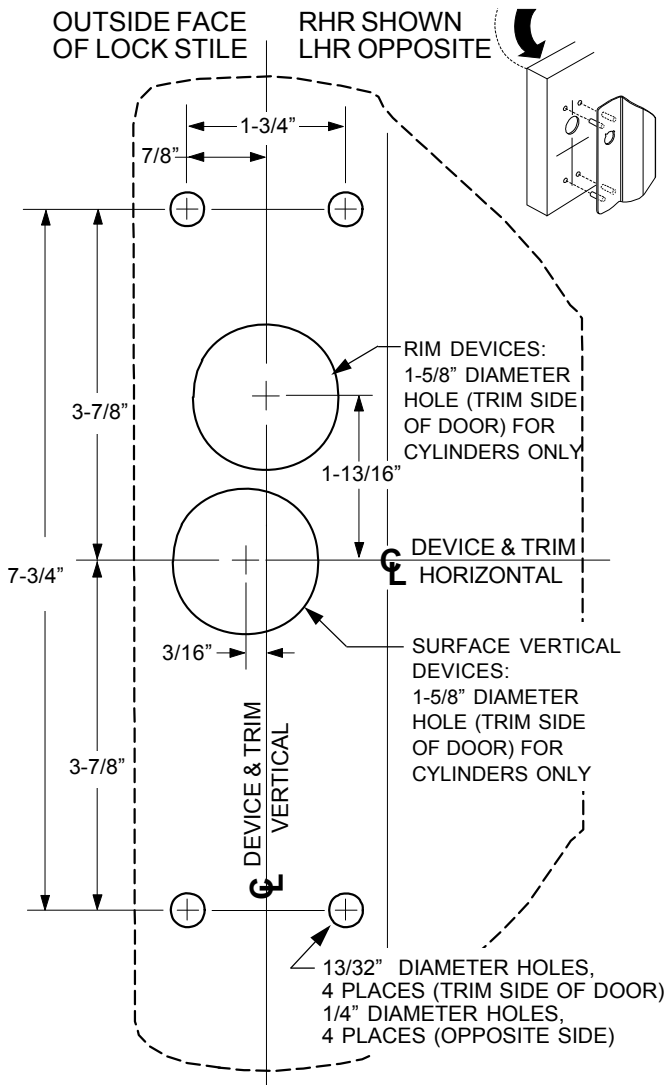

- 3** IF USING A CYLINDER:
 - A** SECURE CYLINDER TO TRIM.
 - B** PLACE TRIM ON DOOR AND CUT CYLINDER TAILPIECE SO IT PROJECTS 1/2" OUT OF DOOR.

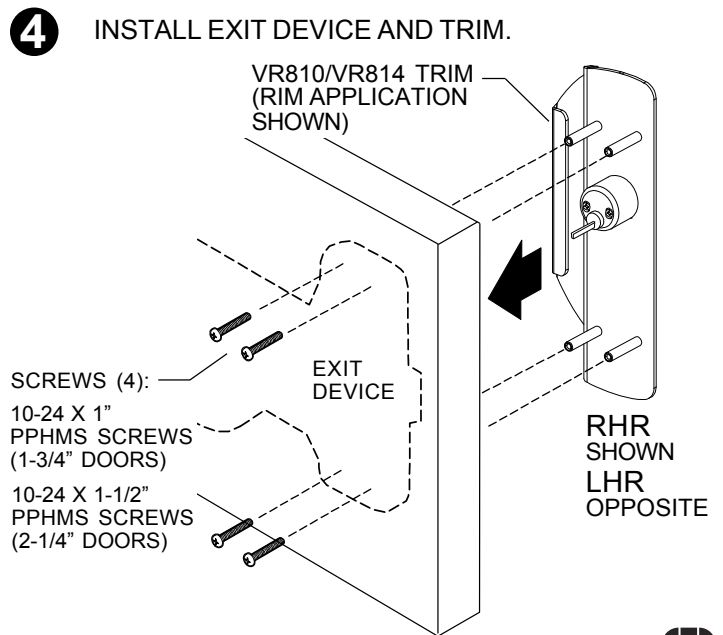

Customer Service
1-877-671-7011 www.allegion.com/us

