

Additional Notes:
2 sheets, 1 fold, side stitched

Revision History						Revision Description:							
E	F	G	H	J	K	K > Allegion Rebranding							
				20156	062621								
Material						Edited By		Approved By		EC Number		Release Date	
White Paper						R. Byun		M. Roberts		062621		05-14-2015	
Notes						Title							
<ol style="list-style-type: none"> printed two sides printed black tolerance: ± .13 see sheet 2 for artwork printed in country may vary drawings not to scale 						F-Series Ethernet Upgrade Instruction							
Creation Date			Number			Revision							
08-29-11			70200-0014			K							
Created By			Activity			Allegion			Copyright © 2015				
J. Ellis			3899 Hancock Expwy Security, CO 80911										



70200-0014

F Series Ethernet Upgrade

Installation Instructions



Ethernet Requirements

- A TCP/IP network
- CAT 5 cable or better
- 10baseT
- Static IP address, gateway and subnet addresses (if needed)
- Port 3001 must be opened

Power Up

A reader with an Ethernet adapter installed and the network cable plugged in will automatically detect the presence of the Ethernet adapter upon power up. If the network cable is not plugged in prior to power being applied, the Ethernet adapter will not see the network and the reader will ask if the cable is plugged in. Plug in the network cable and power cycle the reader. When the reader boots up and detects the network, the LCD will display an IP address and then proceed to either the “Enter ID” or “Ready” prompt.

Address Requirements

The EN-100/200 does not support DHCP; therefore a static IP address is required and must be programmed into the reader before the adapter will communicate with the network.

Obtain all addresses that are required for the network from the system administrator of the site. If there is no need for a gateway address, set it to all zeros (i.e. 000.000.000.000). If the reader is required to communicate over a WAN, the subnet mask needs to be converted to a host bit number. If a subnet mask is not needed, set the host bit to 0. Have the system administrator set Port 3001 to allow access on all switches and routers between the EN-100/200 and host program.

To configure the Ethernet adapter, follow these steps:

1. The reader’s IP address resides in the SET SERIAL command of the SETUP menu, which is by default in the menu 2 of the reader.
2. Press # when the LCD display shows.

SET SERIAL
* NO YES #

3. Enter the 12 digit IP address using leading zeros and press #.
4. Enter the 12 digit gateway using leading zeros or enter all zeros if no gateway is required then press #.
5. Enter the host bits if the reader will be communicating over a WAN, or leave the host bits set to 0 if not needed and then press #.
6. Press CLEAR twice to exit menu.

Subnet to Host Bits Conversions

The readers will only accept a host bit, so the subnet mask needs to be converted. The only legal subnet masks and host bits are listed below:

SUBNET MASK	HOST BITS
255.255.255.255	0
255.255.255.254	1
255.255.255.252	2
255.255.255.248	3
255.255.255.240	4
255.255.255.224	5
255.255.255.192	6
255.255.255.128	7
255.255.255.0	8
255.255.254.0	9
255.255.252.0	10
255.255.248.0	11
255.255.240.0	12
255.255.224.0	13
255.255.192.0	14
255.255.128.0	15
255.255.0.0	16
255.254.0.0	17
255.252.0.0	18
255.248.0.0	19
255.240.0.0	20
255.224.0.0	21
255.192.0.0	22
255.128.0.0	23
255.0.0.0	24

Installing the EN-200 Ethernet Adapter

→ The EN-100 Ethernet adapter is not field installable. Call the factory for installation.

- ⚠ **CAUTION:** This procedure requires a cold boot. Back up all data with the host program before proceeding.
- ⚠ **CAUTION:** If the reader is equipped with an optional battery backup, remove the J7 jumper before proceeding. Failure to do so could lead to risk of shock and/or main board damage, if the ground strap were to touch the main board. See figure 9.
- ⚠ **CAUTION:** Before removing the back plate of reader, wear a grounding wrist strap to help aid in protecting the circuit board from any ESD damage that might occur from improper handling.

1. Unlock the reader and rotate.
2. Disconnect the power supply from the board.
3. Remove and tag all external connections to make correct re-attachment.
4. Remove HandReader from wall by sliding it to the right, away from the wall mount. See figure 1 below.

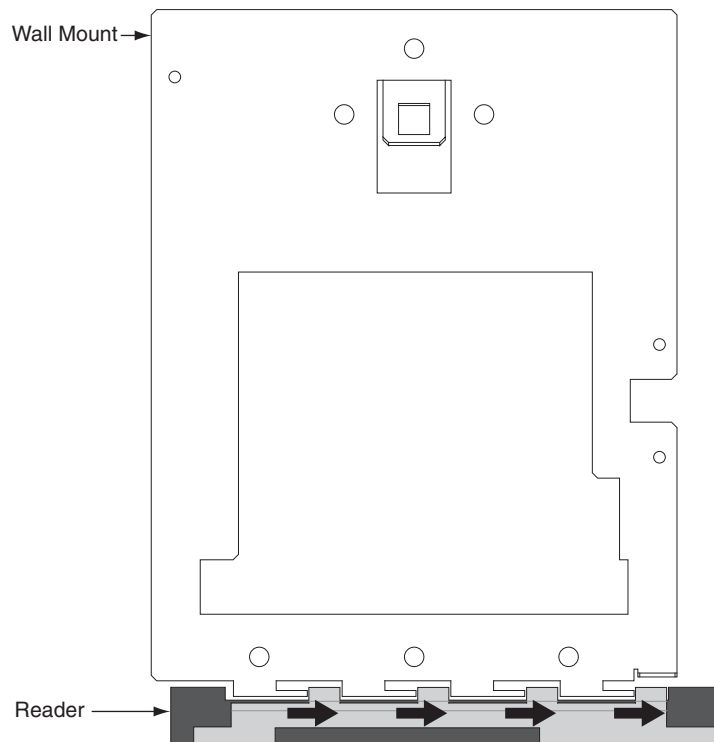

Figure 1

- Set the reader on a firm surface such as a table. Remove the four screws that secure the back plate to the reader. Remove the grounding screw and/or ground lug (if present). See figure 2 below.

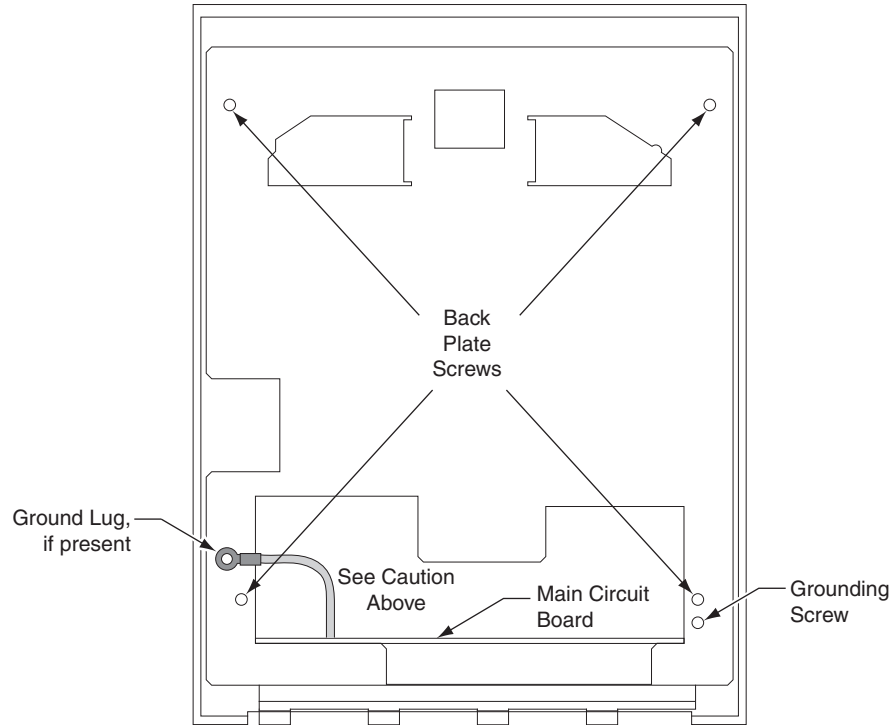

Figure 2

- Carefully remove the back plate.
- Locate the cable on the left side of the reader that runs from the top panel circuit board to the main circuit board. Disconnect this cable from J9 on the main circuit board. See "1" on figure 3. To remove the J9 connector from the main circuit board, depress the retaining clip on the connector and pull upwards. Take care to pull on the connector and to not pull on the cable. See figure 4 below.

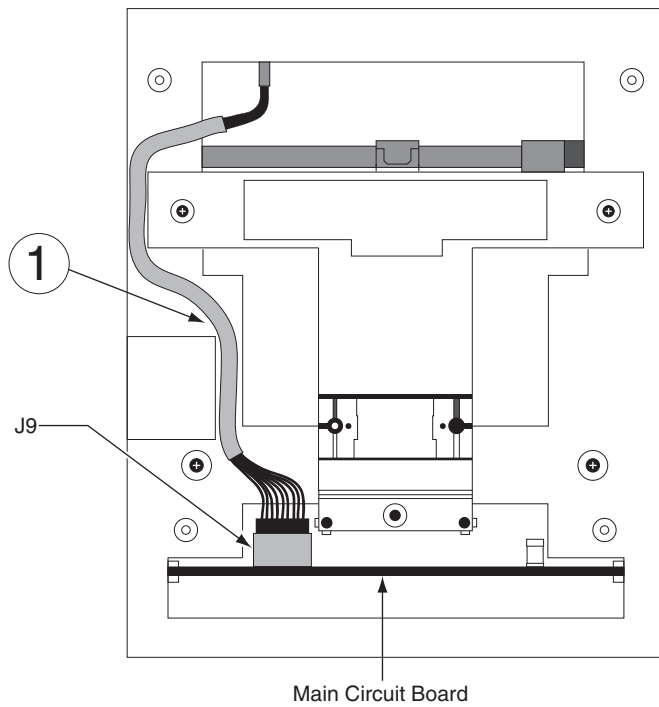

Figure 3

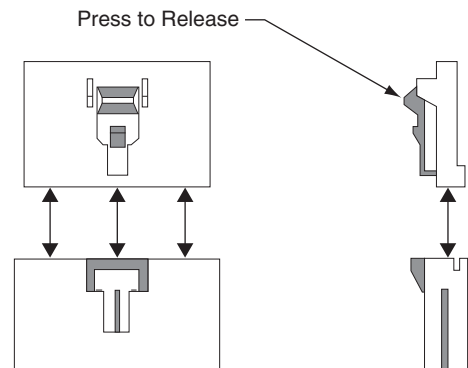

Figure 4

- Carefully slide the main circuit board out until the ribbon cable between the camera assembly and J2 on the main circuit board is accessible. First, disconnect the J5 connector from the main board. To remove, depress the retaining clip on the J5 connector and pull upwards. See “2” on figure 5 below. Next, remove the ribbon cable from J2 by gently pulling up on this cable, being careful not to pull down as damage may occur to the camera assembly. See “3” on figure 5 below.

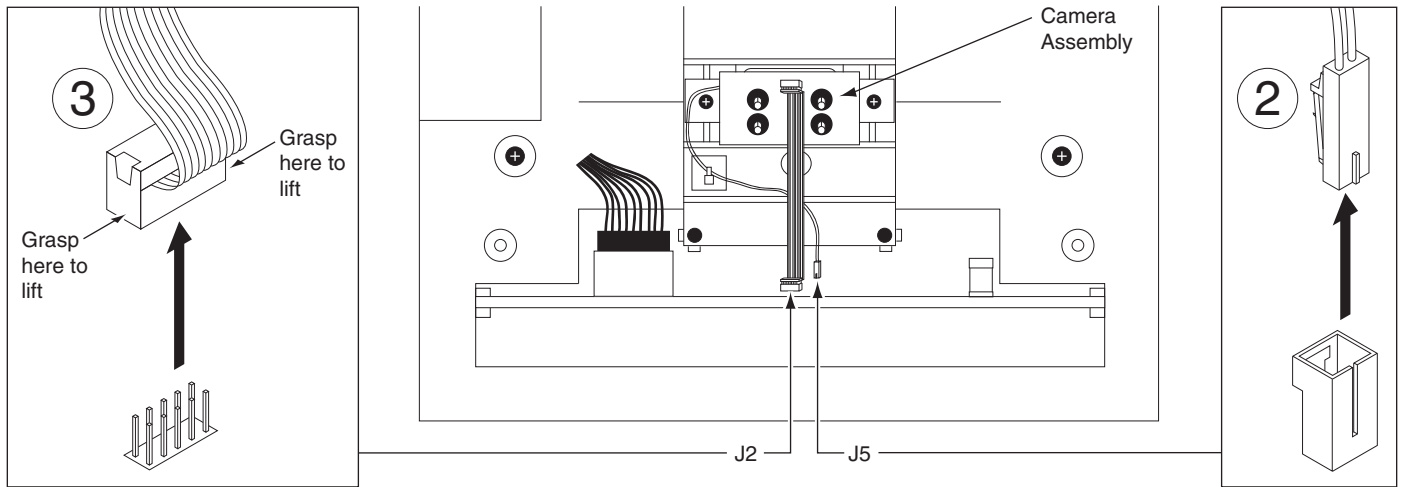
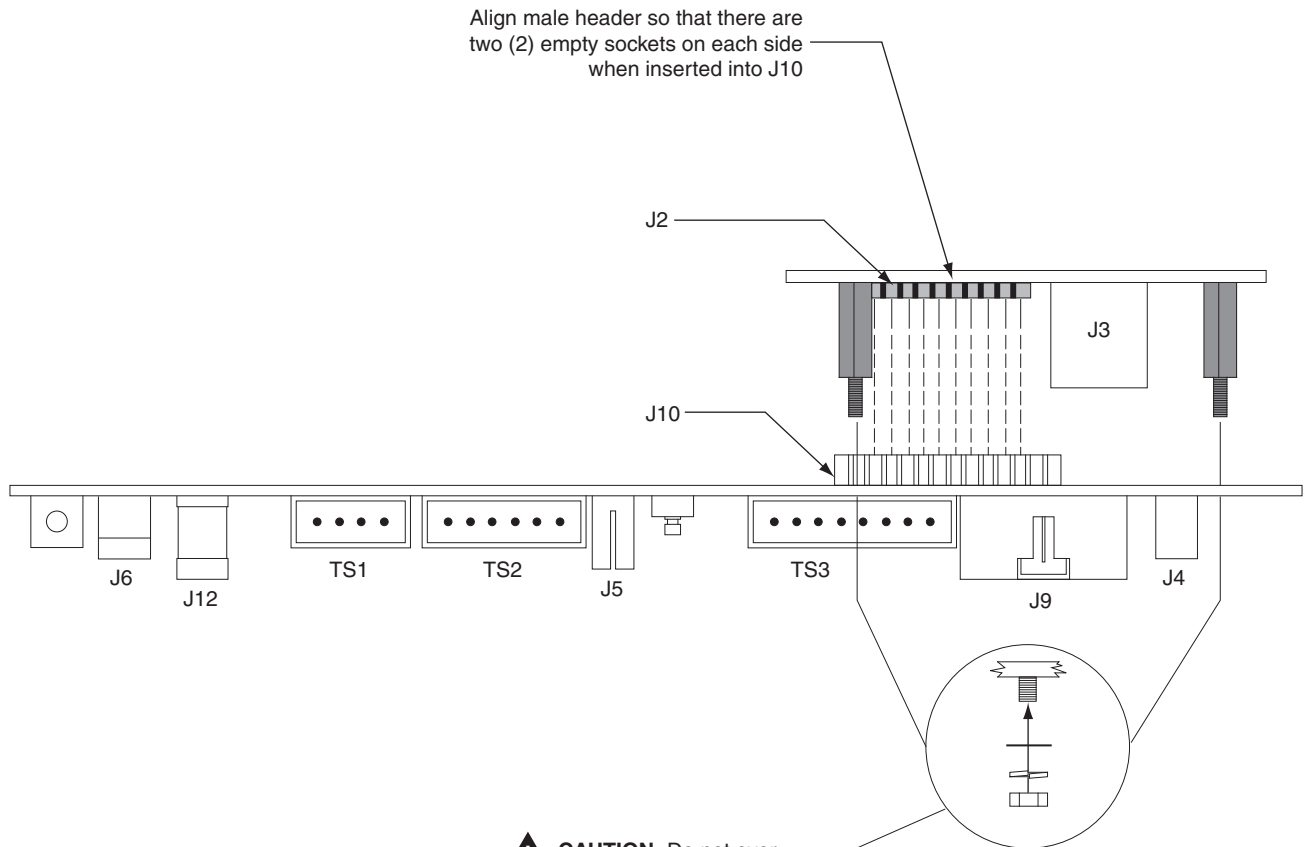

Figure 5

- Carefully remove the main circuit board by sliding it free from the chassis.
- Align the Ethernet adapter and carefully press the Ethernet card into place. Install the washers and nuts to secure the adapter. See figure 6 below.

CAUTION: Torque the 4-40 nuts to 4.5 – 5.5 in. lbs. (.51 - .62 Nm). Excessive torque may damage the circuit boards. After installing the Ethernet card, inspect for warped Ethernet or main PCBs.



CAUTION: Do not over torque the nuts. See step 10 for limits.

Figure 6

11. Carefully slide the main circuit board back into the chassis using the guides to align the board correctly. Leave the main circuit board out about 1”.

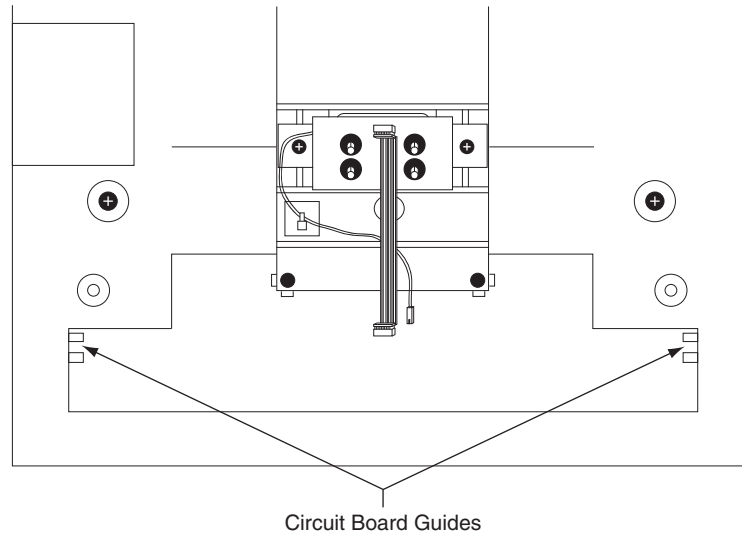

Figure 7

12. Attach the camera cable to J2 on the main circuit board. Take care to align the connector to the pins on the main circuit board and do not twist the cable, as this will damage the camera.
13. Plug in the J5 connector.
14. Locate the cable that runs from the top panel circuit board to the main circuit board. Connect this cable to J9 on the main circuit board. See figure 8 for cable routing.

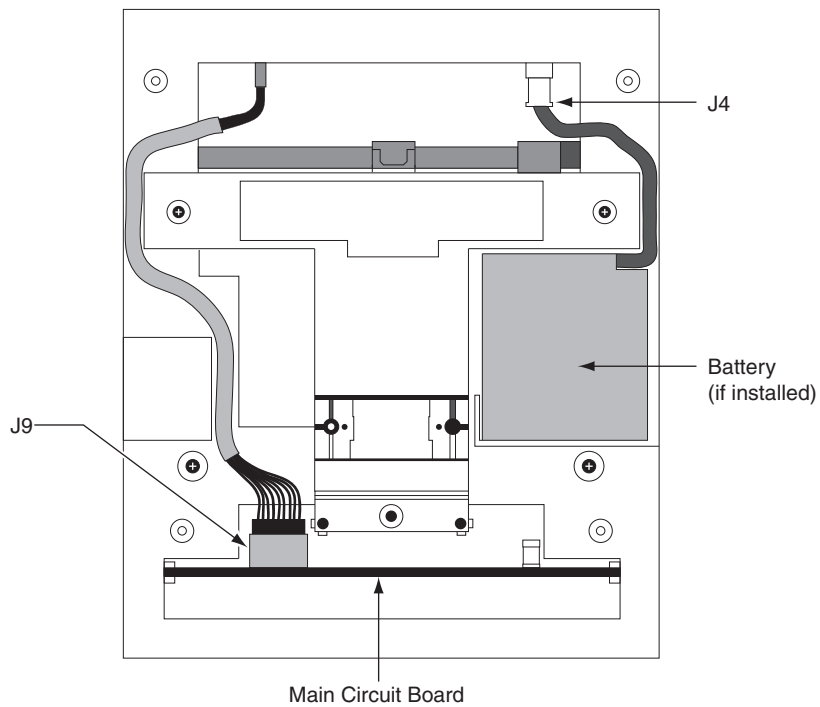

Figure 8

15. Slide the main circuit board in the rest of the way.
16. Replace the back plate. Attach the grounding screw to the main circuit board using the lower right hole on the back plate. If a ground lug is present, do not allow it to come into contact with J7. Secure the back plate with the four screws removed in step 5.
17. Line up the slots at the bottom of the reader's back with the four hinge pins at the bottom of the wall mount. Slide the reader to the left so the pins go in the slots. This fastens the reader to the wall and wall mount and forms a hinge.
18. Reconnect all external connections removed in step 3.
19. Hold down reset button and apply power. Once the reader has booted up, release the reset button.
20. Press "9" on the keypad to complete the reset when prompted.
21. Reconnect the J7 jumper (if applicable).

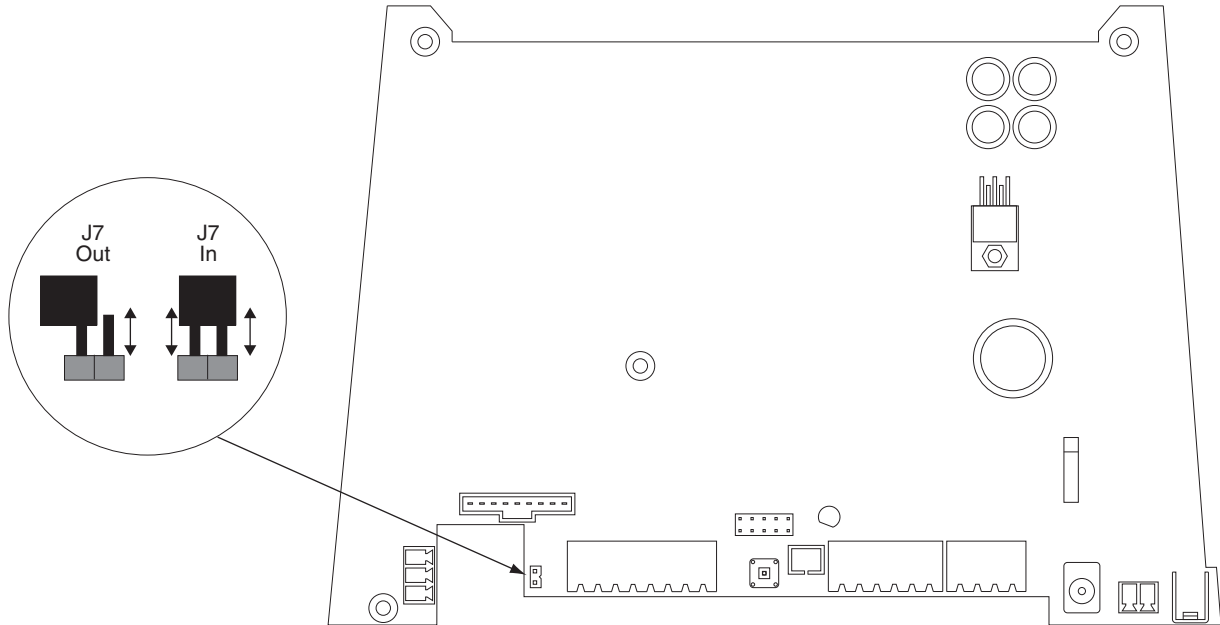

Figure 9

22. Secure the unit to wall mount with key. Upgrade is completed.

What do the LEDs on the Ethernet adapter mean?

1. Steady red or yellow LED:
 - This means the Ethernet adapter has finished booting up but has not tried to detect a network cable plugged in.
2. Red or yellow flashing:
 - This means the Ethernet cable is not plugged in or no network is detected.
3. Red or yellow and green LEDs are both flashing:
 - This means the Ethernet cable has been detected but IP address entered at the reader has not been sent to the Ethernet adapter yet. This status is normally not seen as this process happens quickly.
4. Steady green:
 - This means communication with the network has been established but the host program has not contacted the Ethernet adapter yet.
5. Green flashing:
 - This means everything is ready and messaging can occur when initiated by the host program.

Customer Service

1-877-671-7011

www.allegion.com



© Allegion 2015
Printed in U.S.A.
70200-0014 Rev. 05/15-k