



Wireless Access

INSTALLATION INSTRUCTIONS

**WIRELESS
STATUS MONITOR**

(WSM or AUWSM)

The most current version of this document is available for download at:

<http://www.ir-swa.com>

P/N: M053-032-D





Wireless Access

Schlage
Ingersoll Rand Security Technologies
245 W. Roosevelt Road, Building 7, Suite 48
West Chicago, IL 60185
main: 800-313-2962 (630-876-5680)
technical support: 866-322-1237
fax: 630-293-4257
web: ir-swa.com

Copyright © 2003-2006 Ingersoll Rand, all rights reserved.

No part of this document can be reproduced, transmitted, or transcribed in any form by electrical, mechanical, optical, manual, or otherwise without the prior written consent of Ingersoll Rand. Ingersoll Rand reserves the right to alter or revise the content of this document as needed to support future product revisions, without obligation to notify any persons of specific changes.

The use of trademarks, trade names, or other product identification is solely for reference purposes. All other product brand names are trademarks or registered trademarks of their respective holders.

Ingersoll Rand believes the information in this document to be accurate and reliable. Ingersoll Rand does not guarantee results from the use of this information. Ingersoll Rand assumes no responsibility, obligation, or liability for the information presented in this document.

Ingersoll Rand Security Technologies



INSTALLATION INSTRUCTIONS

Wireless Status Monitor (WSM)

NOTE: These instructions are for installing the Wireless Status Monitor (WSM), a component of a Schlage Wireless Access System. AUWSM is an Australian version of the wireless status monitor.

In this manual, WSM refers to either a WSM or an AUWSM model.

After completing this installation refer to the “Configuring and Operating the Schlage Wireless Access System” manual.

Table of Contents

- 1. Schlage Wireless Access System Components.....4**
 - 1.1 Overview4
 - 1.2 WSM Components & Sales Models5
- 2. Installing the WSM.....6**
 - 2.1 Tools – Hardware Required.....6
 - 2.2 Determining the Best WPIM and WSM Locations6
 - 2.3 Mounting the WSM Components6
 - 2.4 Connecting the Access Control Peripherals.....8
- 3. Contacting Technical Support.....12**
- 4. FCC/UL Compliance & Warnings.....13**
 - 4.1 FCC Compliance13
 - 4.2 ACA Compliance.....13
 - 4.3 UL Compliance.....13
 - 4.4 Warnings.....13
- 5. Revision History.....14**

1. Schlage Wireless Access System Components

1.1 Overview

Every access control system that uses Schlage Wireless Access contains two different types of modules (Figure 1-1):

- at least one Wireless Panel Interface Module (WPIM), and
- at least one Wireless Access Point Module (WAPM)

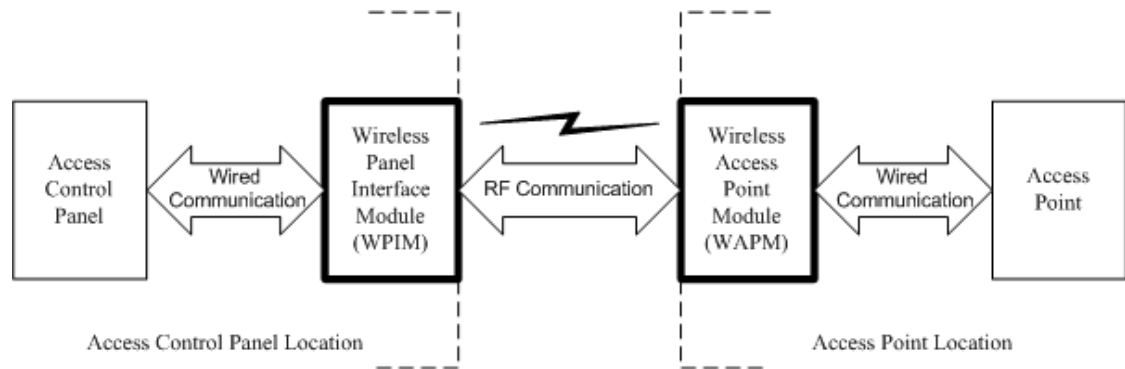

Figure 1-1 – Schlage Wireless Access System Block Diagram

The Schlage Wireless Access product line contains several different expressions of each module.

The WPIM is wired to the access control panel and ideally is installed very close to the access control panel. The WPIMs installation location is determined by the location of the WAPMs with which it will communicate using RF.

The WAPM is installed at the access point where access will be controlled and/or monitored. Depending on the application and which WAPM is used, some wiring at the access control point may be required.

Regardless of which WPIM or WAPM module is used, the communication link between the WPIM and WAPM is always RF.

This manual describes the installation of a Wireless Status Monitor (WSM) which is a WAPM.

1.2 WSM Components & Sales Models

The WSM includes a Transceiver Control Module, and a Battery Pack (located inside the Transceiver Control Module) (Figure 1-2 and Figure 1-3).



Transceiver Control Module

Figure 1-2 – WSM



Figure 1-3 – WSM Battery Pack

MODEL	MOUNTING	LOCATION
WSM	surface	indoor
AUWSM	surface	indoor

Table 1-1- WSM Sales Model Table



2. Installing the WSM

2.1 Tools – Hardware Required

- Hammer
- 9/32" & 3/4" drill bits
- Flat and Phillips head screwdrivers (1/8" wide flat blade for screw terminals)
- Pencil
- Transceiver Control Module Mounting Kit, provided, including four #8 X 2 1/2" screws, four heavy-duty anchors, four washers and four 1" high round spacers

2.2 Determining the Best WPIM and WSM Locations

Proper selection of WPIM and WSM Transceiver Control Module mounting locations insures reliable RF communications.

The WPIM manual contains a section for determining the best location for the WPIM.

The maximum distance between WPIM and a WSM Transceiver Control Module is 200' horizontally when installed inside a building on the same floor that uses normal building construction materials. Never locate the WSM and WPIM more than one (1) floor apart. If on different floors, limit the maximum horizontal distance to 100'. The maximum distance is 1000' for a line of sight installation.

This section provides additional application specific help and guidelines to select the best mounting location for the WSM Transceiver Control Module:

- Mount the WSM Transceiver Control Module inside the protected area.
- Mount the WSM Transceiver Control Module on the wall, at least 55" from the floor
- A WSM Transceiver Control Module, in all directions (sides, top, bottom, and back), have a minimum 1" separation from any metal surface. Therefore if the WRI-IN must be mounted on a metal surface, though not recommended, the supplied 1" spacers must be used.

NOTE: A WSM located with a substantial steel barrier intervening between it and the WPIM may require alternate WSM and/or WPIM placement in order to ensure reliable RF communications. In these applications, mount the WPIM remote from the access control panel. Choose the WPIM or the WPIM's Remote Antenna location to prevent "RF shadowing" of the WSM from the WPIM.

2.3 Mounting the WSM Components

- 2.3.1 **TRANSCIVER CONTROL MODULE** – A 1” hole is provided in the back of the Transceiver Control Module for routing wires in & out. If needed, additional hole(s) can be drilled in the lower left hand corner of the Transceiver Control Module. Wire routing inside the enclosure is very important. Improper wire routing will reduce the RF range. Keep the wires inside the enclosure as short as possible (i.e. do not coil any excess wire inside the enclosure) (Figure 2-1 & Figure 2-2).

NOTE: Do not run wires across the printed circuit board.

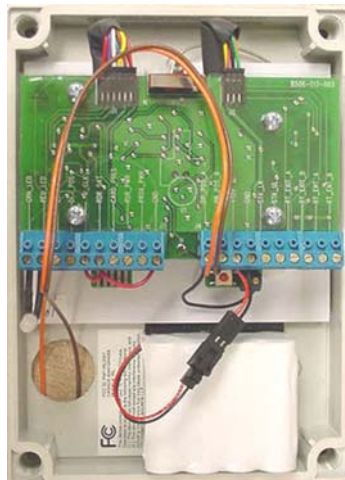

Figure 2-1 – Improper Wire Routing

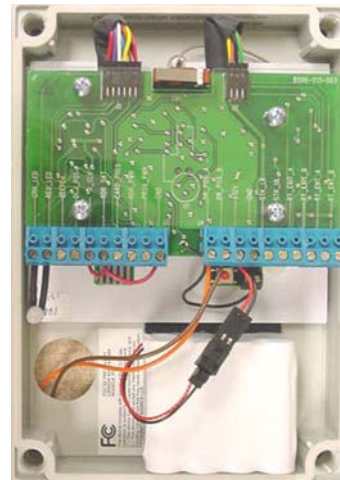

Figure 2-2 – Proper Wire Routing

- 2.3.1.1 Remove the Transceiver Control Module cover.
- 2.3.1.2 Place the Transceiver Control Module (cover removed) against the wall in the position it was successfully “link” tested.
- 2.3.1.3 Using Transceiver Control Module as a template, mark the four corner mounting holes and the 1” wire hole (if used) with a pencil.
- 2.3.1.4 Drill a 9/32” hole at each mounting mark, 1 3/4” deep, and a 1/2” hole at the wire hole mark (if used).
- 2.3.1.5 Insert the four anchors provided firmly into the holes so they are flush with the wall.
- 2.3.1.6 Depending on the installation, you may want to screw the Transceiver Control Module to the wall now or wait until the rest of the components are installed to facilitate wire routing.

If the WSM is to be mounted on a non-metallic surface use the #8, 2 1/2” screws provided to attach the WSM to the wall.

If the WSM is to be mounted on a metallic surface use the round 1” high spacers and the #8, 2 1/2” screws provided to attach the WSM 1” from the wall.

- 2.3.2 **MONITOR POINT DEVICE** – Mount the Monitor Point Device (not supplied) using the installation instructions provided with the Monitor Point Device. Route the Monitor Point Device wires into the Transceiver Control Module.

NOTE: Only Monitor Point Devices with a dry contact switch closure can be used with the WSM. Contacts that use a glass encapsulated reed switch are strongly recommended.

NOTE: If the Monitor Point Device requires power, use a separate power supply. Do not power the Monitor Point Device from the WSM!

2.4 Connecting the Access Control Peripherals

The access control peripherals for the WSM are connected to the Transceiver Control PCB via two 10 terminal connectors, J3 & J4 (Figure 2-3 & Figure 2-4).

The WSM is capable of monitoring and reporting the state of one dry contact Monitor Point Device, usually just a switch. The Monitor Point Device is connected to the WSM through the Door Position Switch Input.

NOTE: Do not use the Request to Exit or Request to Enter inputs to monitor contacts or battery life will be shortened!

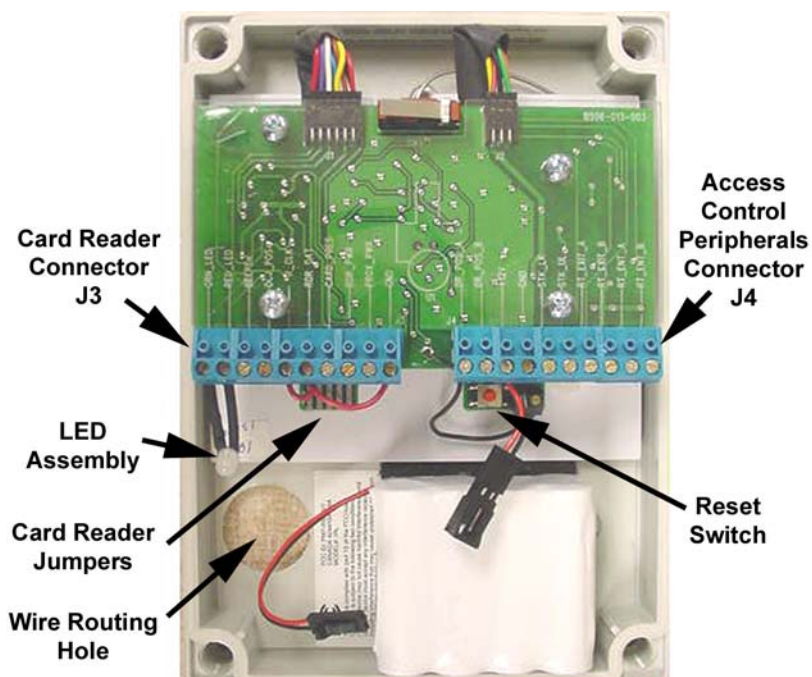

Figure 2-3 – WSM Transceiver Control Module with Cover Removed

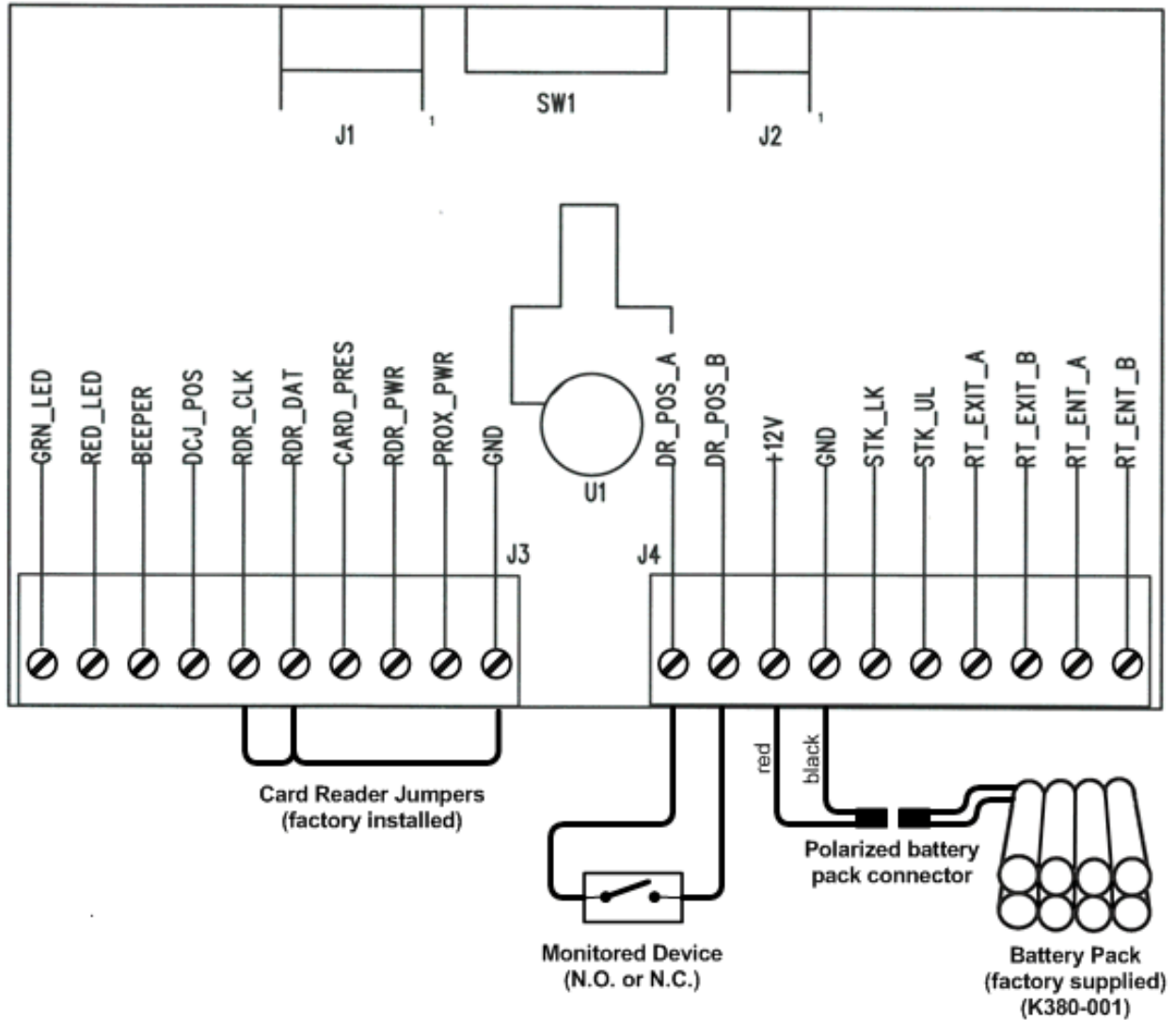

Figure 2-4 – WSM Typical Wiring Diagram

2.4.1 CONTACT MONITOR DEVICE

The Contact Monitor Device connects to the Transceiver Control Module through the Door Position Switch connection on J4 using 2 wires (Figure 2-4). Trim the cable to the desired length, strip the wires, tin the wires, and connect the wires to the mating connector following the information in Table 2-1. Either wire can go to either connection, i.e. the connection is non-polar.

WSM Terminal		Description
J4	DR_POS_A	A dry contact closure across these terminals indicates to the ACP that the contact being monitored is closed.
	DR_POS_B	An open circuit indicates to the ACP that the contact being monitored is open.

Table 2-1 – Door Position Switch Connections (J4)

NOTE: The only recommended Contact Monitor Device to use with a WSM is one that does not require any power. If a powered Contact Monitor Device must be used, then its power must come from a separate power supply and not from the WSM Battery Pack.

2.4.2 CARD READER CONNECTOR

NOTE: The WSM ships with the two reader jumpers already connected.

Although the WSM does not use a card reader, two jumpers need to be added to the Card Reader Connector (J3) to insure that the WSM's DC current draw is minimized to maximize the battery life.

The two reader signal connections, RDR_CLK & RDR_DAT, need to be grounded by jumping them to the GND connection (Figure 2-4 & Table 2-2).

WSM Terminal		Description
J3	RDR_CLK	Card Reader's clock or data1 signal
	RDR_DAT	Card Reader's data or data0 signal
	GND	Card Reader's DC ground

Table 2-2 – Card Reader Connector (J3)

2.4.3 BATTERY PACK INSTALLATION

Although the Transceiver Control Module is shipped with a Battery Pack installed and connected (Figure 2-6), this section details how to install and connect a Battery Pack.

- 2.4.3.1 If the WSM enclosure cover is on, use the Phillips screwdriver to remove WSM cover. There are 4 cover screws, one in each corner (Figure 1-2).
- 2.4.3.2 Install the Battery Pack into the Transceiver Control Module enclosure using the Velcro provided (Figure 2-5).

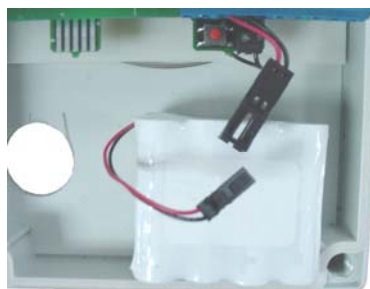

Figure 2-5 – Positioning the Battery Pack to Connect the Wires

2.4.3.3 Connect the Battery Pack Connector to its mating connector that is factory installed on J4 (Figure 2-6).

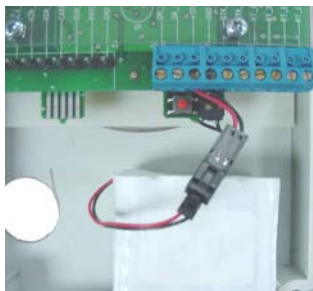

Figure 2-6 – Battery Pack Installed

2.4.3.4 The WSM needs to be linked before installing the WSM cover, follow the instructions in the “Configuring & Operating a Wireless Access System” manual.

If the WSM is not going to be linked immediately following this installation install the WSM using the 4 cover screws ((Figure 1-2).

NOTE: Leaving the WSM cover off for extended periods of time with the Battery Pack connected will shorten the expected battery life.

WSM Terminal		Battery Connector Wire	Description
J4	+12V	RED	Positive battery pack wire to this terminal
	GND	BLACK	Negative battery pack wire to this terminal

Table 2-3 – Battery Pack Connections (J4)

This completes the installation of the WSM. Do not install the WSM cover yet, this will be done after the Panel Interface Module (PIM) is installed and during system configuration.

If the Wireless Panel Interface Module (WPIM) that will control this WSM is not installed, now is the time to install it, please refer to the “PIM Installation Instruction” manual.

If the WPIM is installed, then you are ready to configure your Schlage Wireless Access System, please refer to the “Configuring & Operating a Schlage Wireless Access System” manual.



Wireless Access

3. Contacting Technical Support

For questions regarding Schlage Wireless Access:

www.ir-swa.com

main: 800-313-2962 (630-876-5680)

technical support: 866-322-1237

fax: 630-293-4257



4. FCC/UL Compliance & Warnings

4.1 FCC Compliance

- This device has been authorized by the FCC Rules and Industry Canada.
- This device complies with the limits for a Class B digital device and a Class B intentional radiator, pursuant to Part 15 of the FCC Rules and with RSS-210 of Industry Canada. Operation is subject to the following two conditions: (1) This device may not cause harmful interference, and (2) this device must accept any interference received, including interference that may cause undesired operation.
- The Schlage Wireless Access System Component must be installed by qualified professionals or contractors in accordance with FCC part 15.203, Antenna Requirements.
- Do not use any antenna other than the one provided with the unit.

4.2 ACA Compliance

- The Australian version of AUWSM has been authorized by the Australian Communications Authority (ACA).

4.3 UL Compliance

- The Wireless Status Monitor (WSM) is listed under UL294 as an access control system accessory.
- Access equipment manufactured and/or sold by IR Security Technologies is not rated for, or intended for use in life safety installations.
- The Wireless Status Monitor (WSM) maximum standby current at 12 VDC is 10mA.

4.4 Warnings

- RF Exposure - To comply with FCC RF exposure requirements for mobile transmitting devices this transmitter should only be used or installed at locations where there is normally at least a 20 cm separation between the antenna and all persons.
- Do not co-locate and operate in conjunction with any other antenna or transmitter.
- Use only the Battery Pack specified in this instruction manual.
- Do not subject Battery Pack to fire or high temperatures.
- Do not attempt to recharge, short out or disassemble Battery Pack.
- Follow local regulations for alkaline battery disposal.
- Immediately remove the batteries and discontinue use if:
 - the product is impacted after which the interior is exposed, or
 - the product emits a strange smell, heat, or smoke.
- Changes or modifications not expressly approved by IR Security Technologies could void the user's authority to operate the equipment.



5. Revision History

Version	Date	Changes
X001	08/05/03	preliminary in house release for comments
X001.1	08/11/03	made minor corrections, updated figures showing WSM
001	08/13/03	made minor corrections, released for publication
002	09/16/03	updated wiring diagram
003	12/01/03	made minor corrections, added more conditions to best WPIM & WSM locations, changed wording in Monitor Point Device section
C	05/16/05	Changed name of product from Wireless Contact Monitor (WCM) to Wireless Status Monitor (WSM), changed contact info throughout manual.
D	10/31/06	made minor edits and corrections, updated pictures, added Schlage logo, changed Ingersoll-Rand to Ingersoll Rand, changed Security & Safety to Security Technologies, removed address from cover page, changed wyreless to wireless, removed all TM 's, changed www.wyrelessaccess.com to www.ir-swa.com , changed technical support # to 866-322-1237, added Australian model number: AUWSM, added when to use spacers paragraphs