

**General Information .....23**

**Flush frames.....25**

    F Series ..... 25

    FN Series 1" flush face..... 29

    MU Series multi-use ..... 33

    FE Series double egress.....37

    DE Series double egress ..... 41

**Drywall frames.....45**

    DW Series..... 45

    K Series.....49

**Frames: Variations and options.....53**

**Frames: Anchoring systems .....79**

F and FN Series frame construction

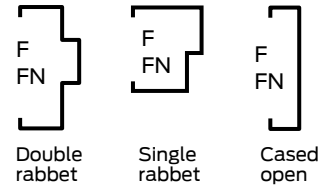

MU Series frame construction

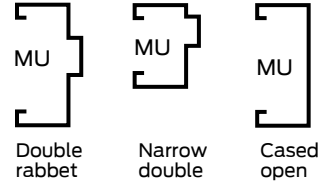

FE and DE Series double egress frame construction

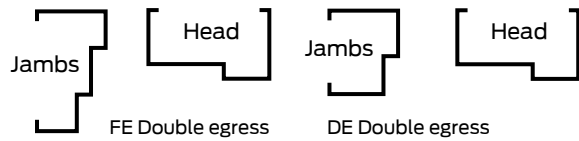

DW and K Series frame construction

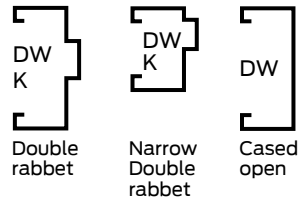

This page intentionally left blank

## General frame information

Steelcraft framing systems are designed to fit virtually all construction requirements for commercial and institutional building applications. Their construction, durability and flexibility have been proven throughout the world in both operation and physical testing of all types.

The **F, FN, FE, DE, and MU Series** frames are designed for installation as part of the wall framing sequence, and installed in interior and exterior applications. When installed, this frame series will either wrap or butt up against the wall construction. Anchoring will be either into the masonry wall, or to the stud wall framing systems.

The **DW and K Series** frames are designed for interior application and for installation in rough openings after the wall is erected and finished. They can be installed in minutes and can be relocated without damage to the frame. When installed, this frame series will wrap the wall construction. Anchorage will be compression fit to the stud systems.

## Sizes and performance

All framing systems are manufactured and supplied to meet the dimensional standards and performance levels as published in ANSI A250.8-2003 (commonly referred to as SDI 100).

Special size products are available to meet the unique construction, performance and aesthetic requirements of the Architectural community. Contact Steelcraft for those requirements.

## Usage and application

To help simplify the use, selection and specification of Steelcraft framing systems, the following guidelines for base material selection can be used:

**Material gauge:** the following material thicknesses are available:

- **16 gauge** [0.053" (1.3mm)]: for Heavy Duty Commercial and Institutional applications with high use.
- **14 gauge** [0.067" (1.7mm)]: for Extra Heavy Duty Commercial and Institutional applications with the potential of very high use.
- **12 gauge** [0.093" (2.3mm)]: for Maximum Duty Commercial and Institutional applications with extremely high use.

**Material selection:** in addition to the thickness of base material, the following base material types of metal are available:

- Commercial quality cold rolled steel conforming to ASTM specifications A1008, A568, and A569 is commonly used on interior openings.
- Galvannealed Steel conforming to ASTM specification A653 is recommended for use on exterior openings or for interior locations where high humidity is present.

## Steel frames

Three sided steel frames are furnished in three pieces (two jambs and a head) which are anchored to the wall systems. The most common 3-sided frame components are:

1. **Hinge jamb:** vertical frame member on which the door is hinged. [For double doors (pairs), there are two hinge jambs and no strike jamb].
1. **Strike jamb:** vertical frame member into which the door latches. [For double doors (pairs), there is no strike jamb, but there are two hinge jambs].
2. **Head:** horizontal frame member which connects the jambs.

## How they are supplied

The connecting corners of the 3-piece frame include precision factory die miters with interlocking tabs and corner clips. The corner miters are specially designed to insure a tight closed corner connection when assembled and installed properly. There are two methods of furnishing 3-sided frames to the job site:

- **Knock Down (KD):** Frames are supplied in 3 pieces for assembly prior to installation at the job site by the installing contractor. This is an economical method of supplying the frames, and at the job site, there is less space consumed in staging the products, easier job site movement of material, and, usually less damage to the frame prior to installation.
- **Set-Up and welded:** Prior to arriving at the job site, the 3-sided frame (with factory miters) is assembled (at the distributor's fabrication location, or by Steelcraft). The miters are welded (in accordance with ANSI A250.8-2003), finished and supplied to the job site ready for installation. **Welded frames are shipped to the job site with temporary shipping bars attached. The temporary shipping bars must be removed prior to installation. When installing frames, the temporary shipping bars must not be used as spreader bars or installation bracing.**

## Job site storage

Frames shall be stored under cover on 4" (101.6mm) wood sills, on the floor, in a manner to avoid contact with moisture, and to prevent rust and damage. Only use vented plastic or canvas. The use of no-vented materials, create a humidity chamber, which promotes blistering and corrosion. Assembled frames shall be stored in a vertical position, five (5) units maximum in a stack. Provide a ¼" (6.3mm) space between the frames to provide air circulation.

## Installation

Proper frame installation is critical for reliable door and hardware functionality. To insure proper fit, function and reliability, install all frames in accordance with ANSI A250.11 and HMMA 840.

Profile terminology

The frame profile has specific terminology related to each surface. Their jamb depth describes the frame size required. It is critical that the throat opening of the frame be compatible with the wall to which it will be attached.

Double rabbet: standard profile

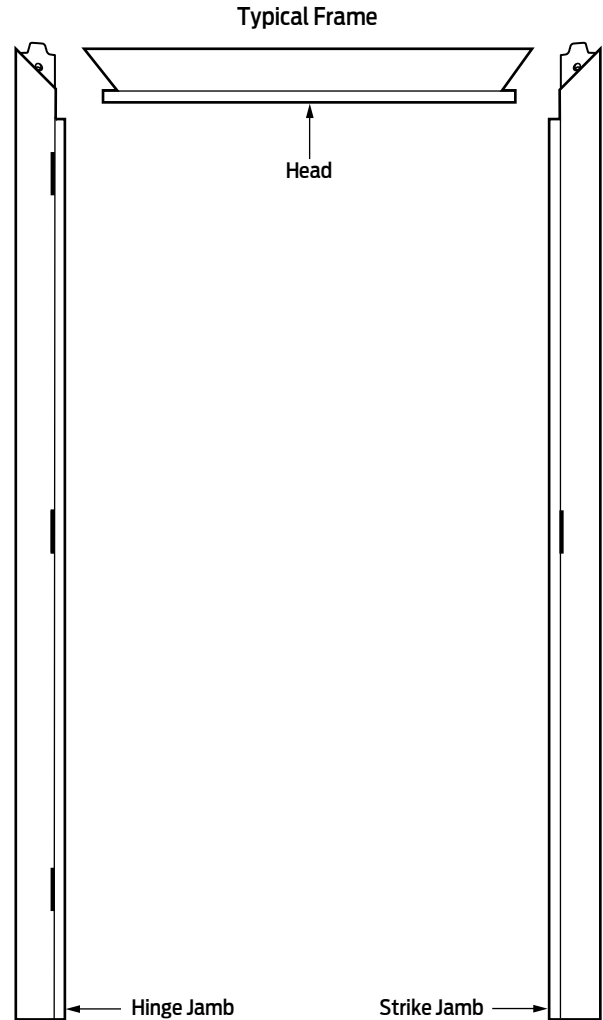
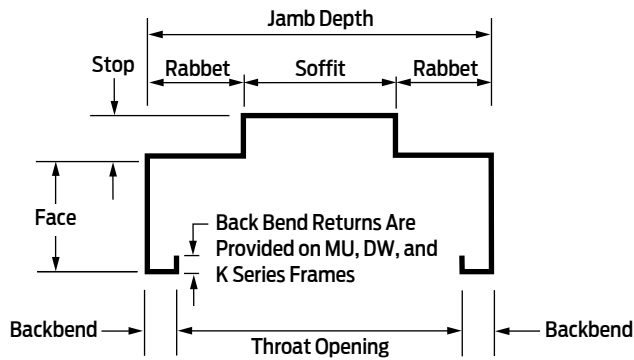

Profile variations

Steel frames are supplied standard as double rabbet. To accommodate various application needs, the frame profile (in any frame series) can change. Some of the typical variations are as follows:

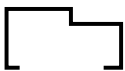

**Single rabbet:** Jamb depths below 4-1/2" (114mm) are single rabbet due to the dimensional limitations of the profile. Some specifications will require single rabbet profiles on frames over 4-1/2" (114mm) in jamb depth.

Profile as shown will vary on MU, DW, and K Series frames, refer to the appropriatedata sheets.

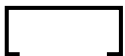

**Cased open:** Used for double acting doors (swinging in both directions), sliding doors, bi-fold doors or frames used to close-off an opening in a wall when a door is not required.



**Double egress:** This is a frame specifically designed for cross corridor applications where traffic control is required. **This frame is not available in the Drywall Series (DW and T) or Multi-Use Series (MU).**

Anchors

Frames must be anchored to the applicable wall construction. Wall construction at door openings must be of sufficient construction to support commercial or institutional grade steel doors and frames. Refer to the appropriate frame data sheets since anchor types will vary with frame constructions and noted in this manual. Basic guidelines is as follows:

Flush frames:

- **Base anchors:** one located at the bottom of each jamb
- **Jamb anchors:** Locate anchors near each hinge location in both hinge and strike jambs. Transom frames require additional anchors above the top hinge.
- **Head anchors:** For wide frame openings usually over 60" in width, an anchor located in the center of the frame head is recommended

Drywall frames:

- **Base anchors:** two (2) located at the bottom of each jamb
- **Jamb anchors:** Drywall frame includes an adjustable compression anchor near the top of each jamb



## Features and benefits

Steelcraft F Series flush frames offer the following unique features, which enhance long term functionality and durability:

- 1. Die-mitered corner connections:** Die-mitered corner connection at the head and jamb insure an attractive, tight and closed mitered connection. The miter includes 4 corner tabs designed with concealed connection eliminating the need for continuous profile welding.
- 2. Patented universal hinge preparations** allow for easy field conversion from standard weight .134" (3.3mm) thick hinges to heavy weight .180" (4.7mm) hinges.
- 3. Adjustable base anchors** allow for installation adjustment when the floor is not level.
- 4. Factory prepared** for field installed silencers.
- 5. Factory applied baked on rust inhibiting primer** in accordance with ANSI A250.10-1998 (R2004).

## About the product

F Series 3-sided flush frames are designed to meet requirements for light to maximum duty applications in both commercial and institutional buildings. They are installed in both interior and exterior locations, and in virtually all types of buildings and wall constructions. These frames are to be installed as part of the wall framing sequence. They can be specified and supplied as KD (knock-down) for field assembly prior to installation or welded for installation as a complete unit.

## Installation

1. Installation shall conform to the published Steelcraft installation instructions, ANSI A250.11-2001 (formerly SDI 105) *Recommended Erection Instructions for Steel Frames and HMMA 840*.
2. Fire Rated Assemblies must be in accordance with NFPA Pamphlet 80. The *Authority Having Jurisdiction* is the final authority in issues related to the installation and use of installed Fire Rated Doors.

## Specification compliance

1. Overall frame construction for the Steelcraft F Series flush frames meets the requirements of ANSI A250.8-2003 (commonly referred to as SDI-100).
2. Hardware preparations and reinforcements are in accordance with ANSI A250.6-2003. Locations are in accordance with ANSI/DHI A115.

## Fire ratings

The F Series flush frames meet the broadest fire rating requirements. They are listed for installations requiring compliance to both neutral pressure testing (ASTM E152 and UL 10B) and positive pressure standards (UL 10C). Refer to the **Fire Rated Section** of this manual for particular listings.

## Applications

F Series frames are typically installed in wall construction types as defined in the chart below:

### Frame applications

Profile	Steel thickness	Wall construction	Typical wall anchors
F16	16 Gauge [0.053" (1.3mm)]	Wood or steel stud	Lock-in stud anchor
F16	16 Gauge [0.053" (1.3mm)]	Masonry	Wire masonry
F16	16 Gauge [0.053" (1.3mm)]	Existing masonry	Bolted through soffit
F14	14 Gauge [0.067" (1.7mm)]	Wood or steel stud	Lock-in stud anchor
F14	14 Gauge [0.067" (1.7mm)]	Masonry	Wire masonry
F14	14 Gauge [0.067" (1.7mm)]	Existing masonry	Bolted through soffit
F12	12 Gauge [0.093" (2.3mm)]	Wood or steel stud	Lock-in stud anchor
F12	12 Gauge [0.093" (2.3mm)]	Masonry	Wire masonry
F12	12 Gauge [0.093" (2.3mm)]	Existing masonry	Bolted through soffit

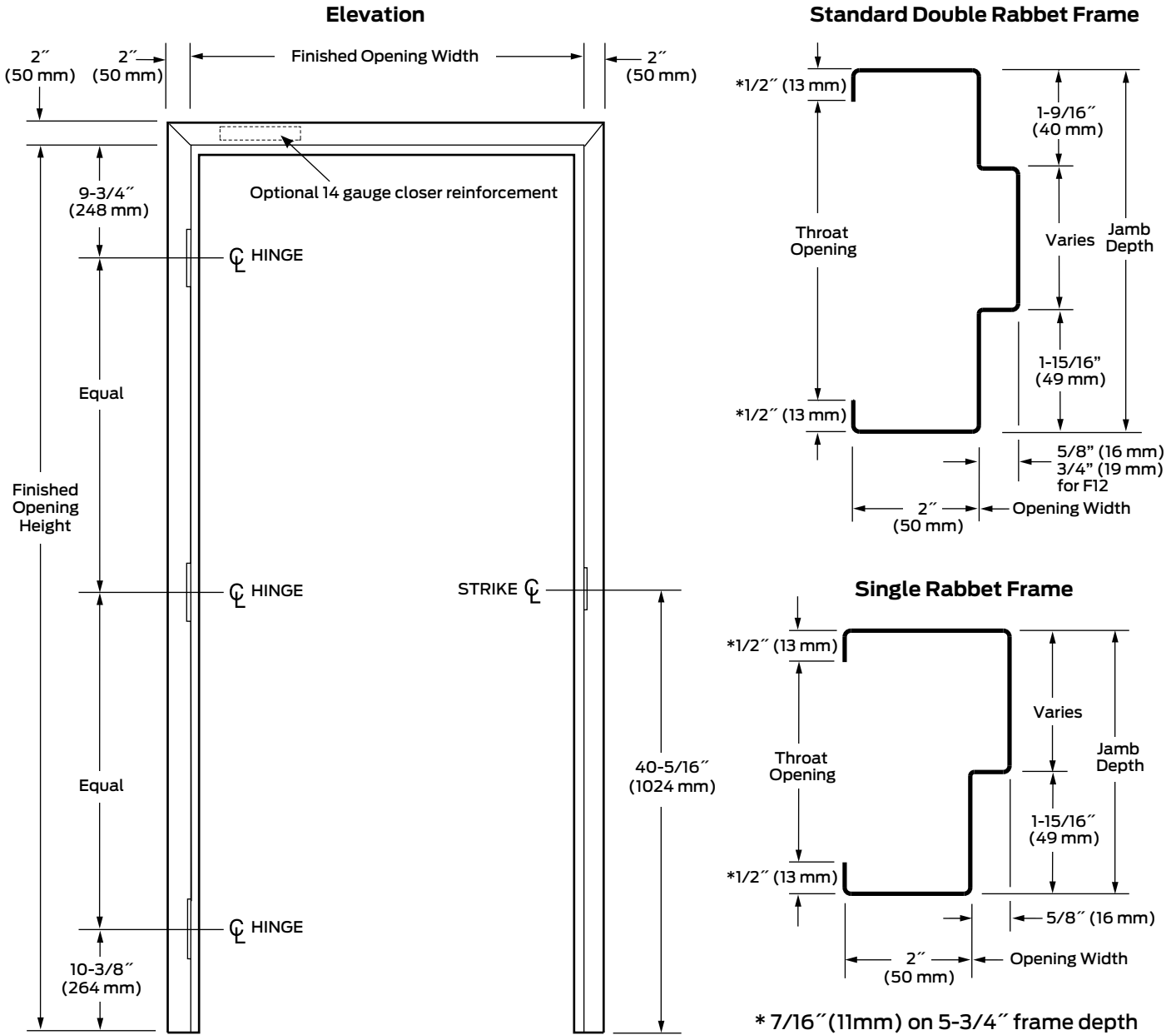

Frame sizing options

Series	Maximum opening size		Jamb depth availability (profile)				Standard profile dimensions (variations available)			Corners
	Single	Pair	Single rabbet		Double rabbet		Face	Stop	Return	
			Minimum	Maximum	Minimum	Maximum				
F16	5'0" x 11'0" (1524mm x 3353mm)	10'0" x 11'0" (2439mm x 3353mm)	3" (76mm)	20" (508mm)	4-1/2" (114mm)	20" (508mm)	2" (50mm)	5/8" (16mm)	1/2"* (13mm)	DIE MITERED with four (4) concealed tabs interlocking head and jambs
F14										
F12	4'0" x 8'0" (1219mm x 2438mm)	8'0" x 8'0" (2438mm x 2438mm)	N/A	N/A	4-3/4" (121mm)	14-3/4" (375mm)	2" (50mm)	3/4" (19mm)	1/2" (13mm)	Square cut for welded corners

\* Except 5-3/4" (146mm) depth, which is 7/16" (11mm) N/A - Not Available | 12 gauge standard profile is equal rabbet

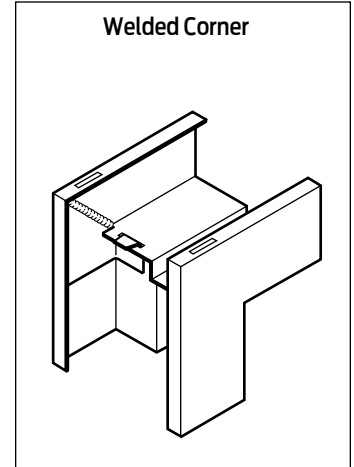
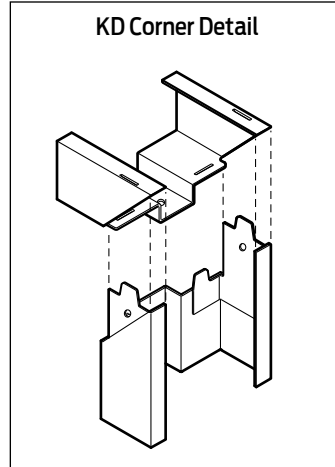
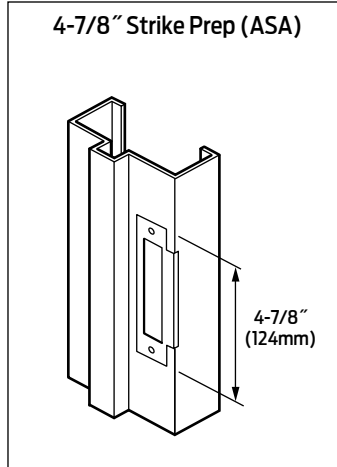
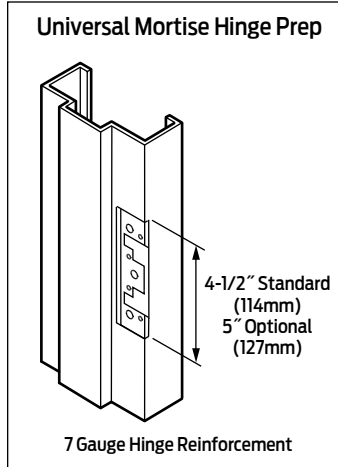

General notes

1. Variations in jamb depths available in 1/8" (3mm) increments.
2. All F Series frames are supplied standard with masonry wire or lock-in jamb anchors and adjustable base anchors. Anchors are designed for maximum wall/frame engagement and installation flexibility.
3. F Series frames are to be installed as part of the wall framing sequence.
4. Depending on environmental and usage conditions the steel can be either cold rolled or galvanized. Galvanized steel is recommended for all exterior applications.
5. 12 gauge flush frames, F12, are standard equal rabbet profiles with 3/4" stops.
6. For KD Corner and optional 4" Head, tabs in rabbeted area should be bent outward, not inward, during assembly (as shown).
1. F Series frames with 4" heads are mainly used in masonry applications when 2" face heads do not match course blocking.

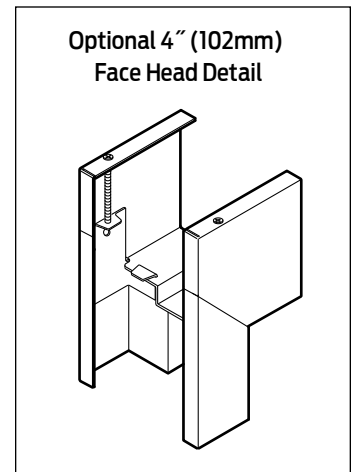

Frame options

Series	Frame profile		Corner connections				4" (102mm) heads
			KD (Knock-down)		SUA (Set-up & weld)		
	Single rabbet	Double rabbet	Single rabbet	Double rabbet	Single rabbet	Double rabbet	
F16	Typically for walls less than 3-3/4" (95mm) thick. Minimum walls thickness 2" (51mm)	Typically for walls less than 3-3/4" (95mm) thickness or greater	3 interlocking corner tabs per factory die-miter. See the "KD Corner Detail	4 interlocking corner tabs per factory die-miter. See the "KD Corner Detail	Available when specified, and in accordance with ANSI A250.8-2003 (SDI 100).		Die-mitered for use with 2" (51mm) face double rabbet jambs. Available when specified for KD or SUA applications.
F14							
F12	N/A		N/A	N/A	Standard Saw Cut and welded, and in accordance with ANSI A250.8-2003 (SDI 100)		For use with 2" (51mm) face double rabbet jambs.

N/A - Not Available

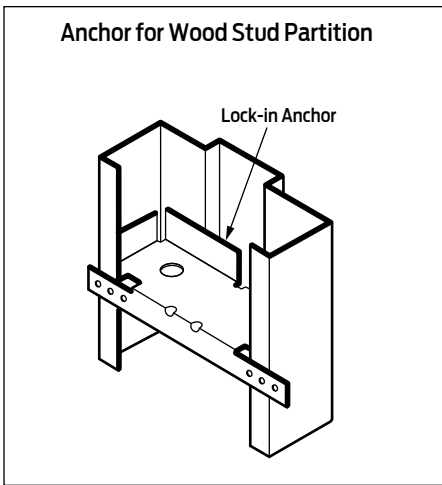
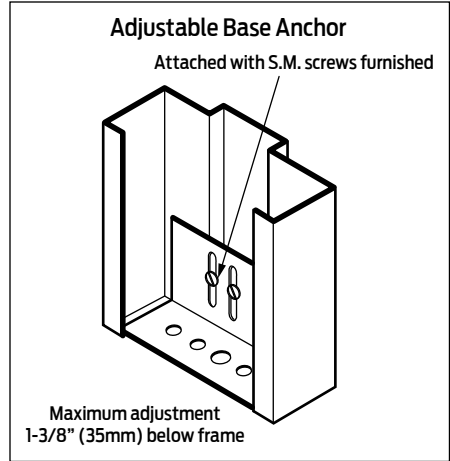
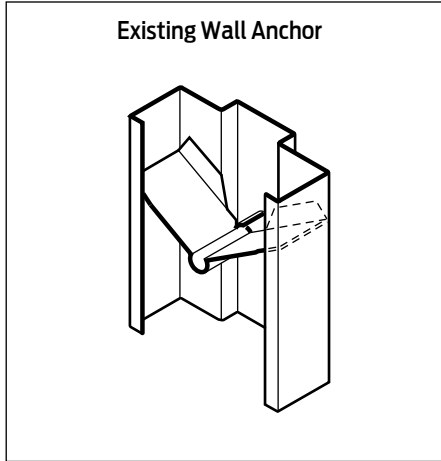
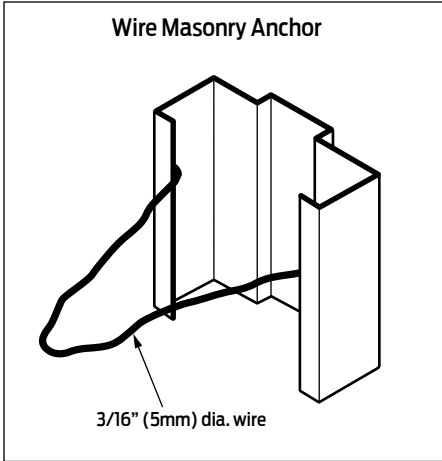

### Anchoring and installation notes

1. **F16 and F14 Series commercial and Institutional frames** are supplied standard with masonry wire or lock-in jamb anchors and adjustable base anchors. Anchors are designed for maximum wall/frame engagement and installation flexibility.
2. **For anchoring applications, refer to the Frames: Anchoring systems section of this manual.**
3. **Installation Caution Notice: Grouted frames:**
  - When temperature conditions necessitate an additive to be used in the mortar to prevent freezing, the contractor installing the frames must coat the inside of frames in the field with a corrosion resistant coating per SDI 105.
  - When frames are to be grouted full, silencers must be field installed prior to grouting.
  - Steel frames, including fire rated frames, do not require grouting. Grouting is not recommended for frames in drywall.
4. All fire rated frames must be installed in accordance with NFPA Pamphlet 80 and the *Authority Having Jurisdiction*.

### Framing applications

Series	Steel type	Building type	Opening	Usage frequency <sup>1</sup>	KD <sup>4</sup> Corner	SUA <sup>5</sup> Corner	Applications
F16	Non-Galvannealed <sup>2</sup>	Institutional and Commercial	Interior	Heavy to extraheavy duty	✓	✓	Typical building conditions
	Galvannealed <sup>3</sup>		Mainly Exterior				High humidity and/or weather exposure
F14	Non-Galvannealed <sup>2</sup>	Institutional and Commercial	Interior	Extra heavy to maximum duty	✓	✓	Typical building conditions
	Galvannealed <sup>3</sup>		Mainly Exterior				High humidity and/or weather exposure
F12	Galvannealed <sup>3</sup>	Institutional and Commercial	Interior and exterior	Maximum duty	N/A	✓	Maximum traffic building conditions
							High humidity and/or weather exposure

1 Usage frequency is based on ANSI A250.8-2003  
 2 Commercial quality cold rolled steel  
 3 Reinforcements for galvannealed frames are also galvannealed  
 4 Knock-Down for field assembly prior to installation  
 5 Set-up and Welded for installation as a pre-welded unit





## About the product

FN Series 3-sided flush narrow 1" (25mm) face frames are designed to meet requirements for light to extra heavy duty applications in both commercial and institutional buildings where a slim face profile is required. They are installed in both interior and exterior locations, and in virtually all types of buildings and wall constructions. These frames are to be installed as part of the wall framing sequence. They can be specified and supplied as KD (knock-down) for field assembly prior to installation or welded for installation as a complete unit.

## Installation

1. Installation shall conform to the published Steelcraft installation instructions, ANSI A250.11-2001 (formerly SDI 105) *Recommended Erection Instructions for Steel Frames and HMMA 840*.
1. Fire Rated Assemblies must be in accordance with NFPA Pamphlet 80. The *Authority Having Jurisdiction* is the final authority in issues related to the installation and use of installed Fire Rated Doors.

## Features and benefits

Steelcraft FN Series 1" (25mm) flush face frames offer the following unique features, which enhance long term functionality and durability. Features can vary depending on the steel thickness of the frame:

1. **Narrow 1" (25mm) face** provides a very slim appearance to the door opening.
2. **Die-mitered corner connections** Die-mitered corner connection at the head and jamb insure an attractive, tight and closed mitered connection. The miter includes 4 corner tabs designed with concealed connection eliminating the need for continuous profile welding.
3. **Patented universal hinge preparations** allow for easy field conversion from standard weight .134" (3.3mm) thick hinges to heavy weight .180" (4.7mm) hinges.
4. **Factory prepared** for field installed silencers.
2. **Factory applied baked on rust inhibiting primer** in accordance with ANSI A250.10-1998 (R2004).

## Specification compliance

1. Overall frame construction for the Steelcraft FN18, FN16 and FN14 Series flush narrow 1" (25mm) face frames meets the requirements of ANSI A250.8-2003 (commonly referred to as SDI-100).
3. Hardware preparations and reinforcements are in accordance with ANSI A250.6-2003. Locations are in accordance with ANSI/DHI A115 unless otherwise stated.

## Fire ratings

The FN Series flush narrow 1" (25mm) face frames meet the broadest fire rating requirements. They are listed for installations requiring compliance to both neutral pressure testing (ASTM E152 and UL 10B) and positive pressure standards (UL 10C). Refer to the **Fire Rated section** of this manual for particular listings.

## Applications

FN Series 1" (25mm) flush face frames are designed to meet the aesthetic needs of a very slender face dimension, and still maintain the functionality of the conventional flush framing systems. The FN Series 1" (25mm) flush face frames are typically installed in wall construction types as defined in the chart below:

## Frame applications

Profile	Steel thickness	Wall construction	Typical wall anchors
FN16	16 Gauge [0.053" (1.3mm)]	Wood or steel stud	Lock-in stud anchor
FN16	16 Gauge [0.053" (1.3mm)]	Masonry	Wire masonry
FN16	16 Gauge [0.053" (1.3mm)]	Existing masonry	Bolted through soffit
FN14	14 Gauge [0.067" (1.7mm)]	Wood or steel stud	Lock-in stud anchor
FN14	14 Gauge [0.067" (1.7mm)]	Masonry	Wire masonry
FN14	14 Gauge [0.067" (1.7mm)]	Existing masonry	Bolted through soffit

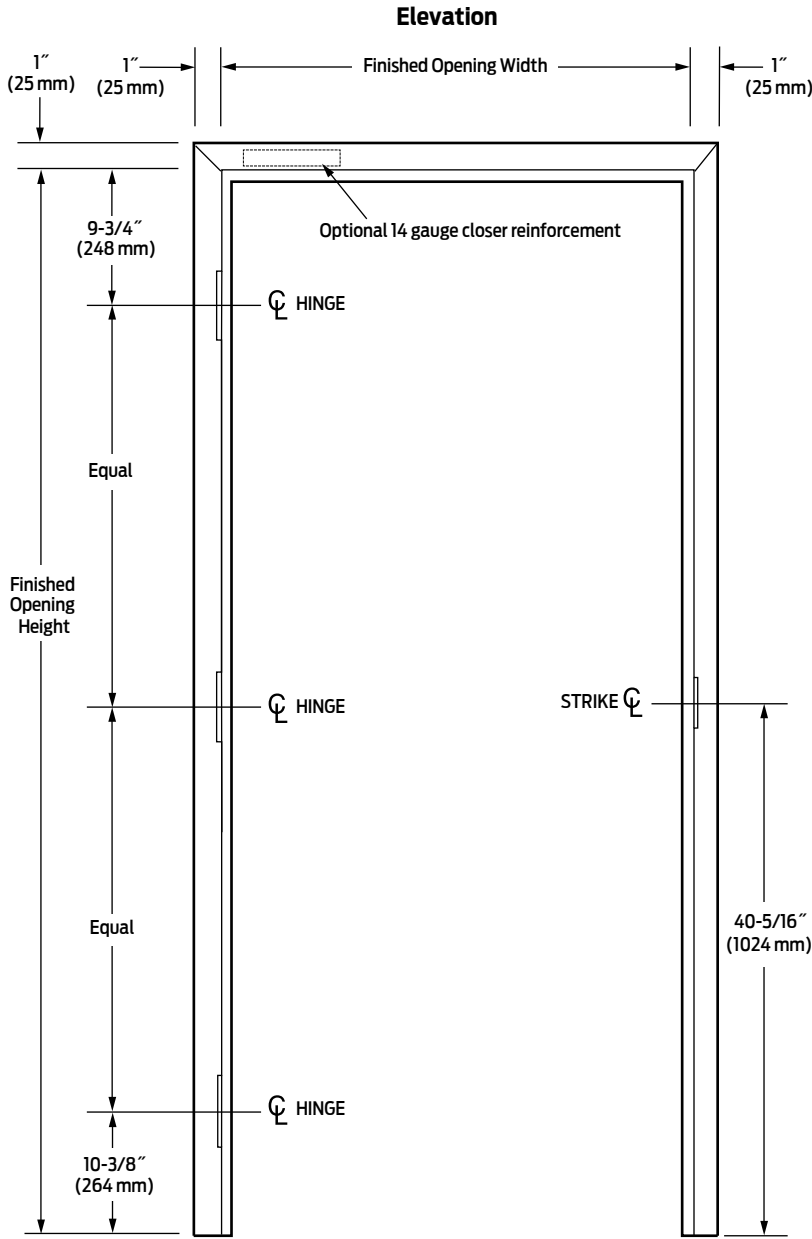

Standard Double Rabbet Frame

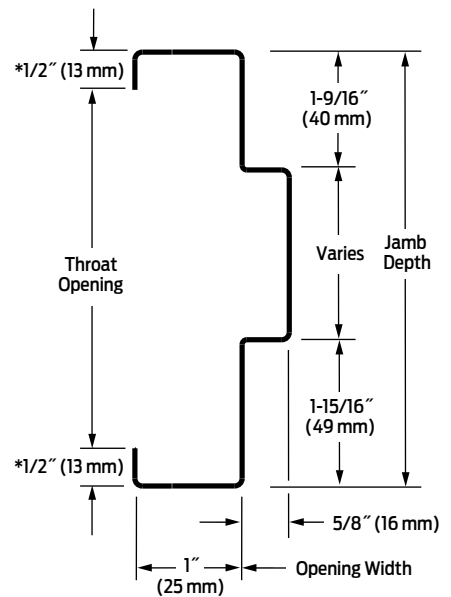

\* 7/16" (11mm) on 5-3/4" frame depth

**Note:**  
FN Series 3 sided flush narrow 1" (25mm) face frames are available as double rabbet only.

Frame sizing options

Series	Maximum opening size		Jamb depth availability (profile)				Standard profile dimensions (variations available)			Corners
	Single	Pair	Single rabbet		Double rabbet		Face	Stop	Returns	
			Minimum	Maximum	Minimum	Maximum				
FN16	4'0" x 8'0" (1219mm x 2439mm)	8'0" x 8'0" (2439mm x 2439mm)	N/A	N/A	4-1/2" (114mm)	20" (508mm)	1" (25mm)	5/8" (16mm)	1/2"* (13mm)	DIE MITERED with four (4) concealed tabs interlocking head and jambs
FN14	4'0" x 8'0" (1219mm x 2439mm)	8'0" x 8'0" (2439mm x 2439mm)	N/A	N/A	4-1/2" (114mm)	20" (508mm)	1" (25mm)	5/8" (16mm)	1/2"* (13mm)	DIE MITERED with four (4) concealed tabs interlocking head and jambs

N/A = Not Available

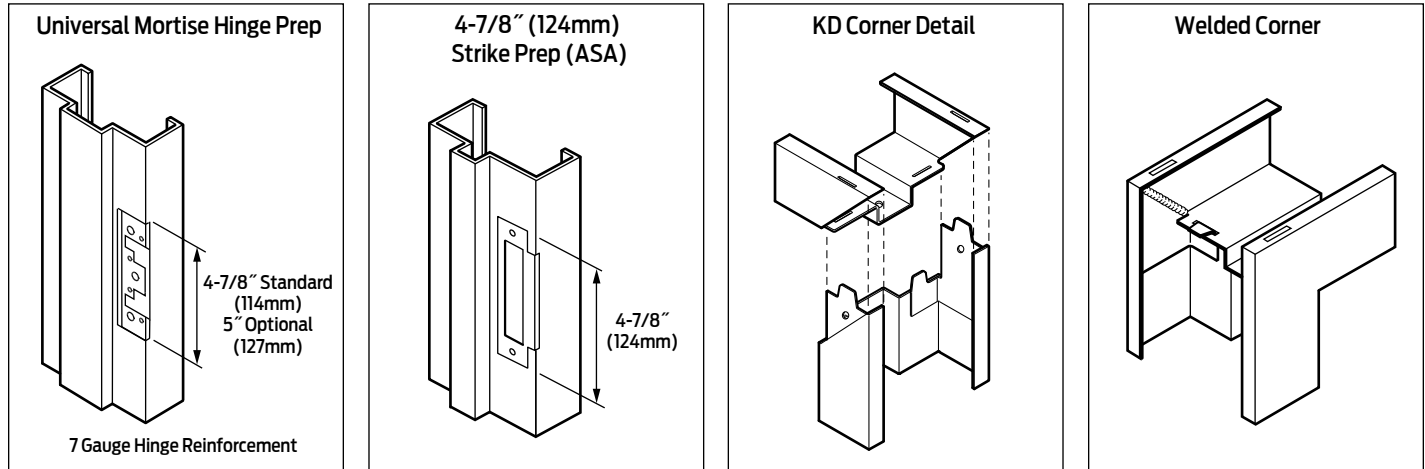

General notes

1. Variations in jamb depths available in 1/8" (3mm) increments.
  2. All FN Series frames are supplied standard with masonry wire and weld-in base anchors. Anchors are designed for maximum wall/frame engagement and installation flexibility.
  3. FN Series frames are to be installed as part of the framing sequence.
  4. Depending on environmental and usage conditions, the steel can be either cold rolled or galvanized. Galvanized steel is recommended for all exterior applications.
1. For KD Corner, tabs in rabbeted area should be bent outward, not inward, during assembly.

Frame options

Series	Frame profile		Corner connections			
			KD (Knock-down)		SUA (Set-up & weld)	
	Single rabbet	Double rabbet	Single rabbet	Double rabbet	Single rabbet	Double rabbet
<b>FN16</b>	N/A	Typically for walls 3-3/4" (95mm) thickness or greater	N/A	4 interlocking corner tabs per factory diameter. See the "KD Corner Detail	N/A	Available when specified, and in accordance with ANSI A250.8-2003 (SDI 100)
<b>FN14</b>	N/A	Typically for walls 3-3/4" (95mm) thickness or greater	N/A	4 interlocking corner tabs per factory diameter. See the "KD Corner Detail	N/A	Available when specified, and in accordance with ANSI A250.8-2003 (SDI 100)

N/A = Not Available

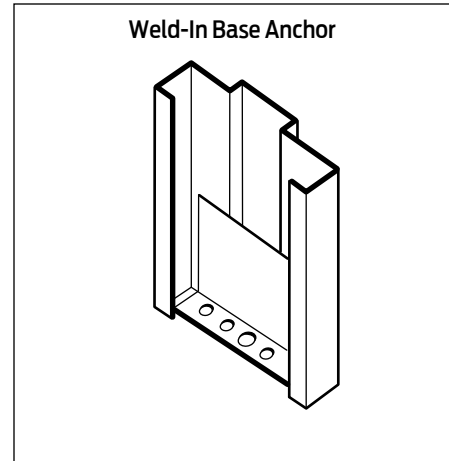
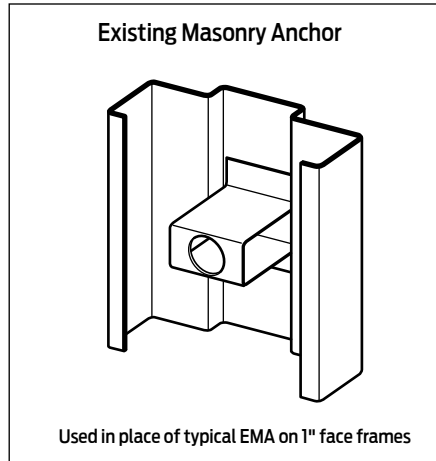
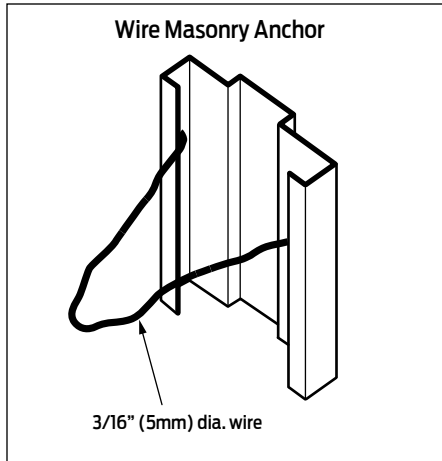

### Anchoring and installation notes

1. **FN16 Series narrow 1" (25mm) Face frames** are supplied standard with masonry wire and weld-in base anchors. Anchors are designed for maximum wall/frame engagement and installation flexibility.
2. **For anchoring applications, refer to the Frames: Anchoring systems section of this manual.**
3. **Installation caution notice: Grouted frames:**
  - When temperature conditions necessitate an additive to be used in the mortar to prevent freezing, the contractor installing the frames must coat the inside of the frames in the field with a corrosion resistant coating per SDI 105.
  - When frames are to be grouted full, silencers must be field installed prior to grouting
  - Steel frames, including fire rated frames, do not require grouting. Grouting is not recommended for frames in drywall.
4. Installation shall conform to the published Steelcraft installation instructions, *SDI 105 Recommended Installation Instructions for Steel Frames*.
1. All fire rated frames must be installed in accordance with NFPA Pamphlet 80 and the *Authority Having Jurisdiction*.

### Framing applications

Series	Steel type	Building type	Opening	Usage frequency <sup>1</sup>	KD <sup>4</sup> Corner	SUA <sup>5</sup> Corner	Applications
FN16	Non-Galvannealed <sup>2</sup>	Institutional and commercial	Interior	Heavy to extra heavy duty	✓	✓	Typical building conditions
	Galvannealed <sup>3</sup>		Mainly exterior				High humidity and/or weather exposure
FN14	Non-Galvannealed <sup>2</sup>	Institutional and commercial	Interior	Extra heavy to maximum duty	✓	✓	Typical building conditions
	Galvannealed <sup>3</sup>		Mainly exterior				High humidity and/or weather exposure

1 Usage frequency is based on ANSI A250.8-2003

2 Commercial quality cold rolled steel

3 Reinforcements for galvannealed frames are also galvannealed

4 Knock-Down for field assembly prior to installation

5 Set-up and Welded for installation as a pre-welded unit



## About the product

Steelcraft's MU Series multi-use flush frames are designed for light to extra heavy duty applications in both commercial and institutional buildings. They can be installed in both interior and exterior locations, and in virtually all types of buildings and wall constructions. They have a jamb profile similar to the DW frames, but are designed to be installed as part of the wall framing sequence. They can be specified and/or supplied as either KD (knock-down) for field assembly prior to installation, or welded for installation as a complete unit.

## Installation

1. Installation shall conform to the published Steelcraft installation instructions, ANSI A250.11-2001 (formerly SDI 105) *Recommended Erection Instructions for Steel Frames and HMMA 840*.
2. Fire Rated Assemblies must be in accordance with NFPA Pamphlet 80. The Authority Having Jurisdiction is the final authority in issues related to the installation and use of installed Fire Rated Doors.

## Features and benefits

Steelcraft MU Series multi-use flush frames offer the following unique features which enhance long-term functionality and durability. Features can vary depending on the steel thickness of the frame:

1. **Die-mitered corner connections** of the MU Series multi-use flush frame corners lock together once the frame is installed. The tab/lock design:
  - a. prevents the head from rising
  - b. keeps the head and jamb members in alignment
  - c. keeps the miter tight
  - d. includes wedge-lock corner clips. Screws are supplied to secure miter.
2. **Patented universal hinge preparations** allow for easy field conversion from standard weight .134" (3.3mm) thick hinges to heavy weight 0.180" (4.7mm) hinges.
3. **Adjustable base anchors** allow for installation adjustment when the floor is not level.
4. **Factory prepared** for field installed silencers.
  1. **Factory applied baked-on rust inhibiting primer** in accordance with ANSI A250.10-1998 (R2004).

## Specification compliance

1. Overall frame construction for Steelcraft MU Series multi-use flush frames meet the requirements of ANSI A250.8-2003 (SDI 100).
2. Hardware preparations and reinforcements are in accordance with ANSI A250.6-2003. Locations are in accordance with ANSI/DHI A115 unless otherwise stated.

## Fire ratings

MU Series multi-use flush frames meet the broadest fire rating requirements. They are listed for installations requiring compliance to both neutral pressure testing (ASTM E152 and UL 10B) and positive pressure standards (UL 10C). Refer to the **Fire Rated Section** of this manual for particular listings.

## Applications

Steelcraft MU Series multi-use flush frames are typically installed in wall construction types as defined in the chart below:

### Frame applications

Profile	Steel thickness	Wall construction	Typical wall anchors
MU16	16 Gauge [0.053" (1.3mm)]	Wood or steel stud	Lock-in stud anchor
MU16	16 Gauge [0.053" (1.3mm)]	Masonry	Wire masonry
MU16	16 Gauge [0.053" (1.3mm)]	Existing Masonry	Bolted through soffit
MU14	14 Gauge [0.067" (1.7mm)]	Wood or steel stud	Lock-in stud anchor
MU14	14 Gauge [0.067" (1.7mm)]	Masonry	Wire masonry
MU14	14 Gauge [0.067" (1.7mm)]	Existing masonry	Bolted through soffit

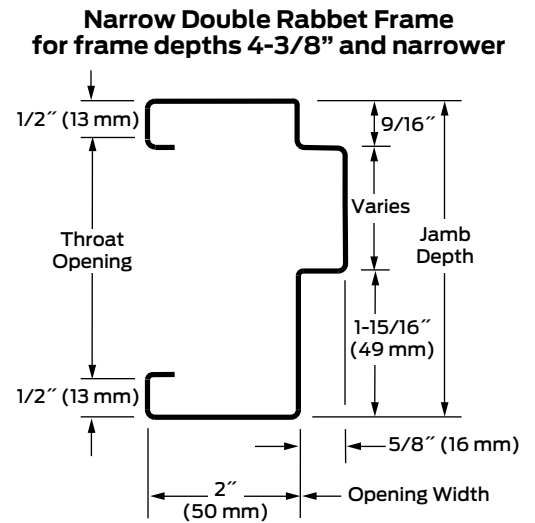
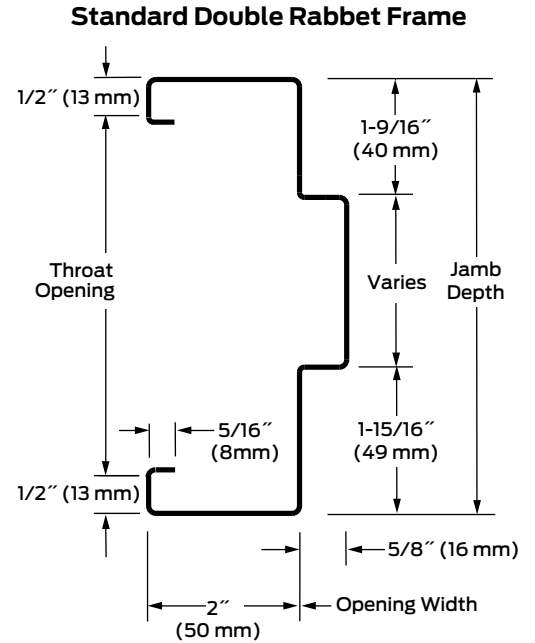
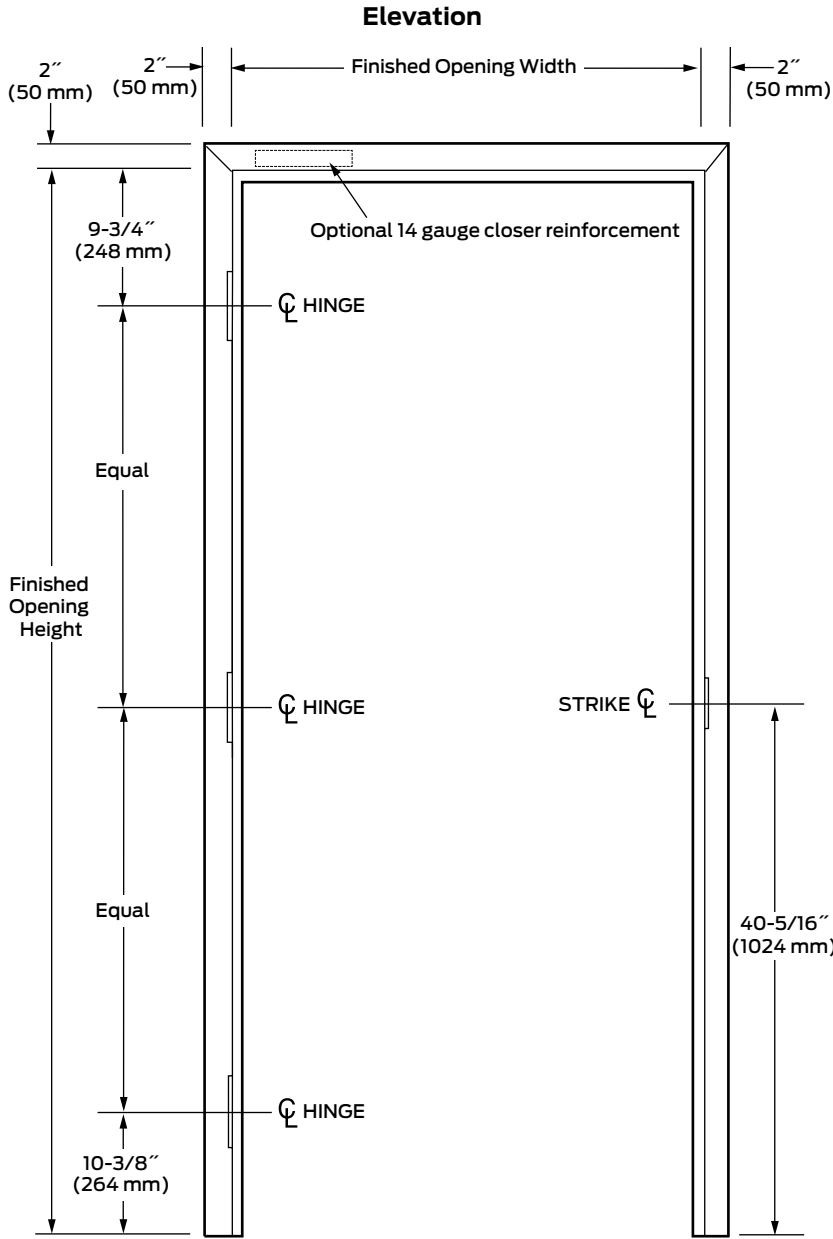

Frame sizing options										
Series	Maximum opening size		Jamb depth availability (profile)				Standard profile dimensions (variations available)			Corners
	Single	Pair	Narrow double rabbet		Double rabbet		Face	Stop	Returns	Standard
			Min.	Max.	Min.	Max.				
MU16	4'0" x 9'0" (1219mm x 2743mm)	8'0" x 9'0" (2439mm x 2743mm)	3-1/4" (83mm)	4-3/8" (111mm)	4-1/2" (114mm)	20" (508mm)	2" (51mm)	5/8" (16mm)	1/2" (13mm)	DIE MITERED with interlocking Soffit tab
MU14	4'0" x 9'0" (1219mm x 2743mm)	8'0" x 9'0" (2439mm x 2743mm)	3-1/4" (83mm)	4-3/8" (111mm)	4-1/2" (114mm)	20" (508mm)	2" (51mm)	5/8" (16mm)	1/2" (13mm)	DIE MITERED with interlocking Soffit tab

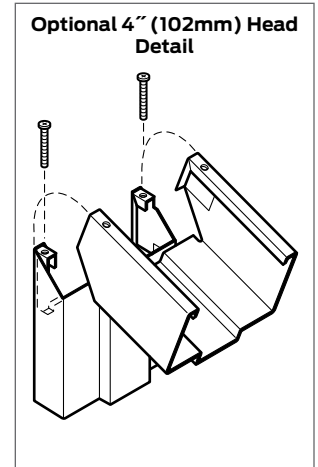
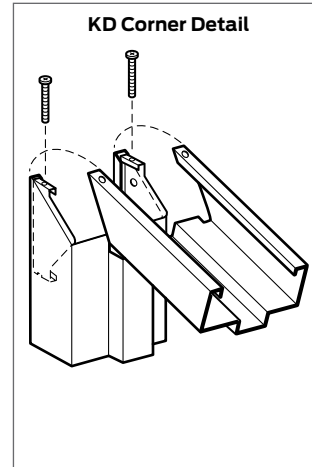
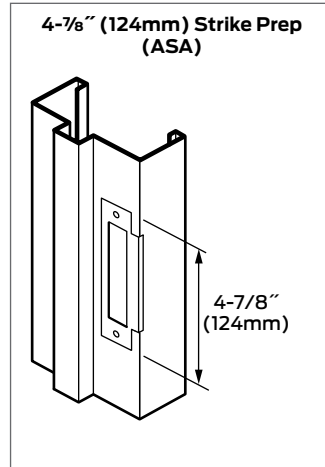
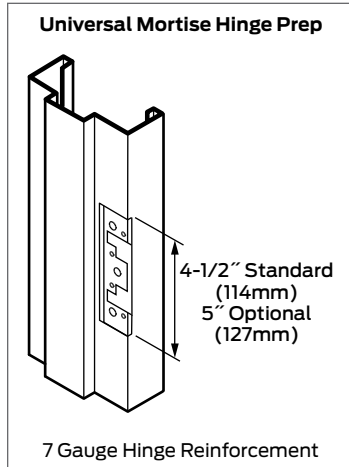

General notes

1. Variations in jamb depths available in 1/8" (3mm) increments.
2. All MU Series frames are supplied standard with masonry wire or lock-in jamb anchors and adjustable base anchors. Anchors are designed for maximum wall/frame engagement and installation flexibility.
3. MU Series frames are to be installed as part of the wall framing sequence.
4. Depending on environmental and usage conditions the steel can be either cold rolled or galvanized. Galvanized steel is recommended for all exterior applications.
5. MU Series with 4" heads are used mainly in masonry applications when 2" face heads do not match block coursing, or in drywall applications when installed in close proximity to a F Series or MU Series frame installed with a 4" head.

Frame options							
Series	Frame profile		Corner connections				4" (102mm) Heads
			KD (Knock-down)		SUA (Set-up & weld)		
	Narrow double rabbet	Double rabbet	Single rabbet	Double rabbet	Single rabbet	Double rabbet	
MU16	Typically for walls less than 3-3/4" (95mm) thick. Minimum walls thickness = 2" (51mm)	Typically for walls less than 3-3/4" (95mm) thickness or greater	Factory Die-Mitered, Soffit Tab included. Corner clip assembly screws required.	Factory Die-Mitered, Soffit Tab included. Corner clip assembly screws required.	Available when specified, and in accordance with ANSI A250.8-2003 (SDI 100).		Die-mitered for use with 2" (51mm) face jambs. Corner Clip assembly screws required.
MU14							

N/A - Not Available

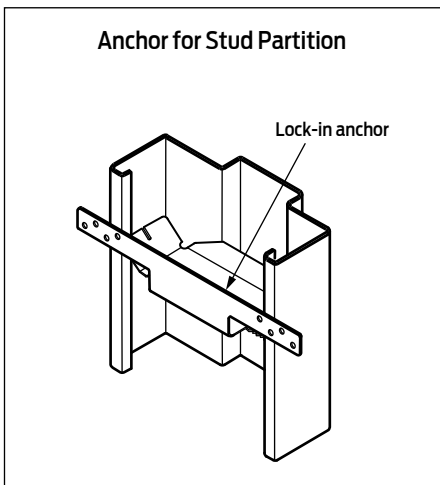
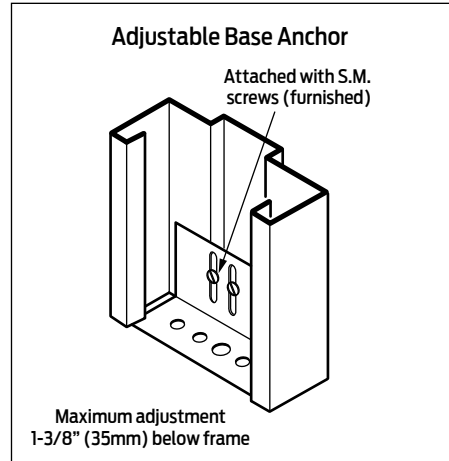
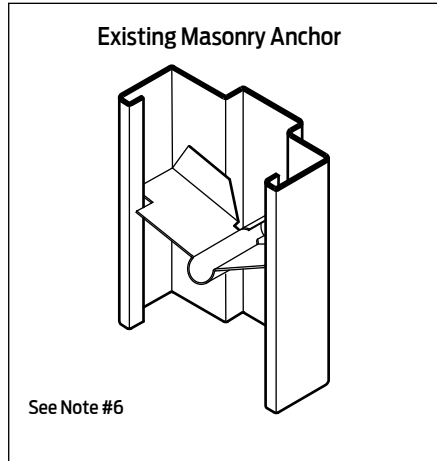
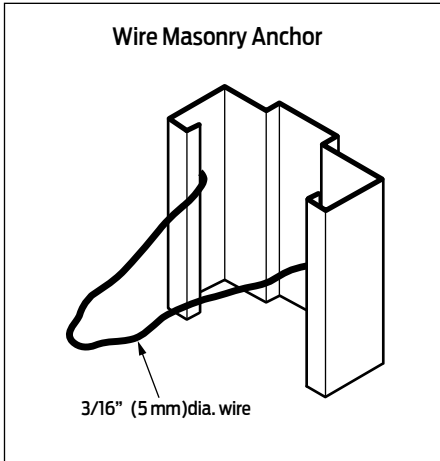

## Anchoring and installation notes

1. **MU16 Series Multi-use flush frames** are supplied standard with masonry wire, or lock-in jamb anchors and adjustable base anchors. Anchors are designed for maximum wall/frame engagement, and installation flexibility.
2. **For anchoring applications, refer to the Frames: Anchoring systems section of this manual.**
3. **Installation caution notice: Grouted frames:**
  - When temperature conditions necessitate an additive to be used in the mortar to prevent freezing, the contractor installing the frames must coat the inside of frames in the field with a corrosion resistant coating per SDI 105.
  - When frames are to be grouted full, silencers must be field installed prior to grouting.
  - Steel frames, including fire rated frames, do not require grouting. Grouting is not recommended for frames in drywall.
4. Installation shall conform to the published Steelcraft installation instructions, SDI 105 *Recommended Installation Instructions for Steel Frames*.
5. All fire rated frames must be installed in accordance with NFPA Pamphlet 80 and the Authority Having Jurisdiction.
  1. When using Standard Exiting Wall Anchors the anchor must be field modified (notched) to provide clearance for the backbend return.

## Framing applications

Series	Steel type	Building type	Opening	Usage frequency <sup>1</sup>	KD <sup>4</sup> Corner	SUA <sup>5</sup> Corner	Applications
MU16	Non-Galvannealed <sup>2</sup>	Institutional and Commercial	Interior	Heavy to extra heavy duty	✓	✓	Typical building conditions
	Galvannealed <sup>3</sup>		Mainly Exterior				High humidity and/or weather exposure
MU14	Non-Galvannealed <sup>2</sup>	Institutional and Commercial	Interior	Extra heavy to maximum duty	✓	✓	Typical building conditions
	Galvannealed <sup>3</sup>		Mainly Exterior				High humidity and/or weather exposure

- 1 Usage frequency is based on ANSI A250.8-2003
- 2 Commercial quality carbon steel
- 3 Reinforcements for galvannealed frames are also galvannealed
- 4 Knock-Down for field assembly prior to installation
- 5 Set-up and Welded for installation as a pre-welded unit





## About the product

The FE Series double egress frames are designed to meet requirements for heavy to extra heavy duty applications in both commercial and institutional buildings. They are installed at interior locations, and in virtually all types of buildings and wall constructions. These frames can be specified and supplied as KD (knock-down) for field assembly prior to installation or welded for installation as a complete unit. If clear opening width for cross corridor applications is critical, refer to the DE Series Frame.

## Installation

1. Installation shall conform to the published Steelcraft installation instructions, ANSI A250.11-2001 (formerly SDI 105) *Recommended Erection Instructions for Steel Frames and HMMA 840*.
1. Fire Rated Assemblies must be in accordance with NFPA Pamphlet 80. The *Authority Having Jurisdiction* is the final authority in issues related to the installation and use of installed Fire Rated Doors. The *Authority Having Jurisdiction* is the final authority in issues related to the installation and use of installed Fire Rated Doors.

## Features and benefits

Steelcraft FE Series double egress frames offer the following unique features, which enhance long term functionality and durability:

1. **Die-mitered corner connections** Die-mitered corner connection at the head and jamb insure an attractive, tight and closed mitered connection. The miter includes 4 corner tabs designed with concealed connection eliminating the need for continuous profile welding.
2. **Patented universal hinge preparations** allow for easy field conversion from standard weight .134" (3.3mm) thick hinges to heavy weight .180" (4.7mm) hinges.
3. **Factory prepared** for field installed silencers.
2. **Factory applied baked-on rust inhibiting primer** in accordance with ANSI A250.10-1998 (R2004).

## Specification compliance

1. Overall frame construction for the Steelcraft FE16 and FE14 Series double egress frames meet and exceed the requirements of ANSI A250.8-2003 (commonly referred to as SDI-100).
2. Hardware preparations and reinforcements are in accordance with ANSI A250.6-2003. Locations are in accordance with ANSI/DHI A115 unless otherwise stated.

## Fire ratings

The FE Series double egress frames meet the broadest fire rating requirements. They are listed for installations requiring compliance to both neutral pressure testing (ASTM E152 and UL 10B) and positive pressure standards (UL 10C). Refer to the Fire Rated Section of this manual for particular listings.

## Applications

FE Series double egress frames are typically installed in wall construction types as defined in the chart below:

### Frame applications

Profile	Steel thickness	Wall construction	Typical wall anchors
FE16	16 Gauge [0.053" (1.3mm)]	Wood or steel stud	Weld-in stud anchor
FE16	16 Gauge [0.053" (1.3mm)]	Masonry	Wire masonry
FE16	16 Gauge [0.053" (1.3mm)]	Existing masonry	Bolted through door rabbet
FE14	14 Gauge [0.067" (1.7mm)]	Wood or steel stud	Weld-in stud anchor
FE14	14 Gauge [0.067" (1.7mm)]	Masonry	Wire masonry
FE14	14 Gauge [0.067" (1.7mm)]	Existing masonry	Bolted through door rabbet

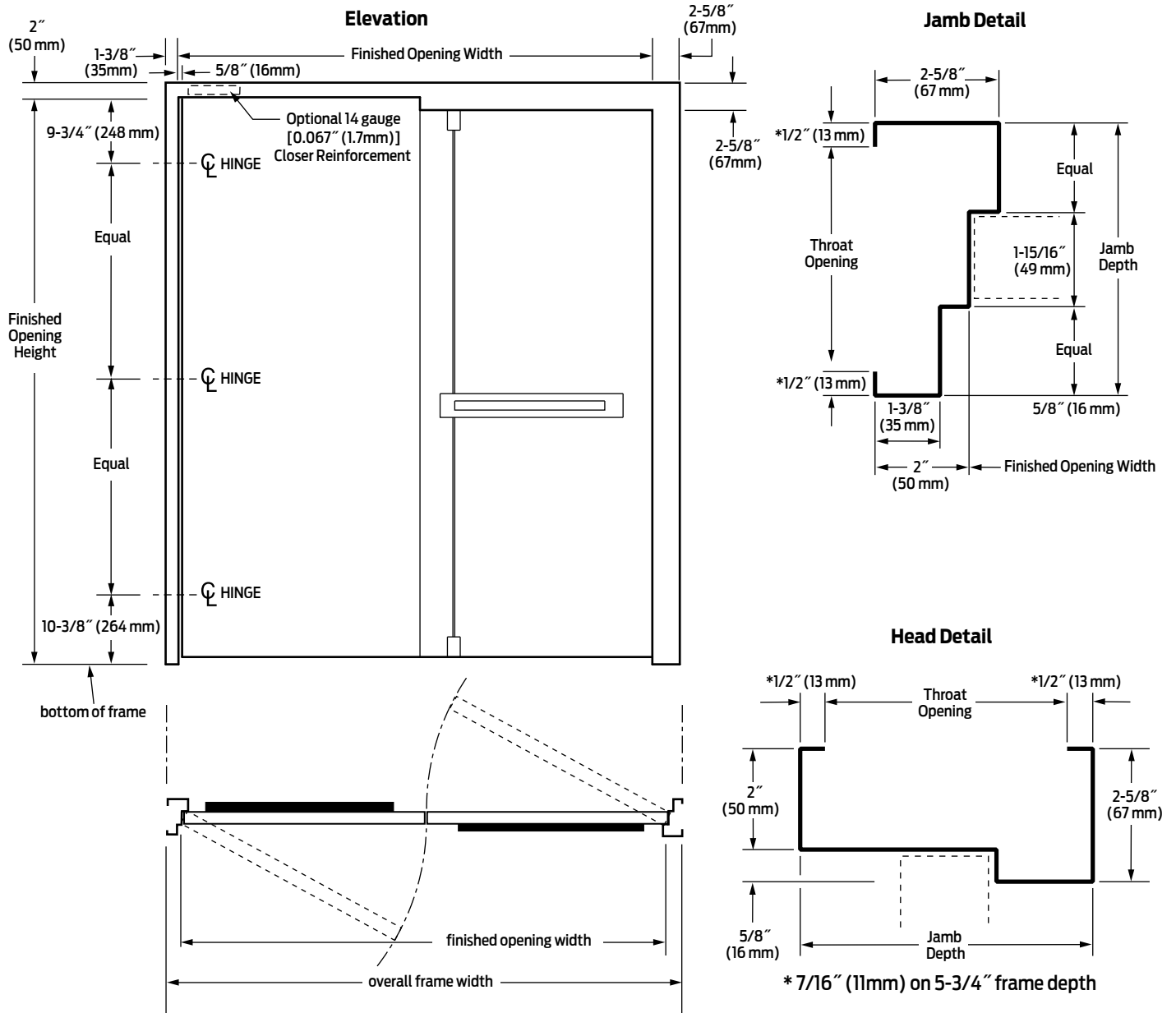

**Finished opening width (Door Opening Dimension) is the dimension from frame door rabbet to the opposite rabbet.** Note: For FE and DE Series double egress frames is 1/8" (3.2 mm) undersized from the standard nominal opening width. Example: 6' 0" (1829 mm) head = 71-7/8" net width in lieu of the standard 72".

Frame sizing options

Series	Maximum opening size	Jamb depth availability (profile)		Standard profile dimensions (variations available)			Corners
		3 step jambs x 2 step heads		Face	Stop	Returns	
		Pair	Minimum				
FE16	8' 0" x 10' 0" (2439mm x 3048mm)	4-3/4" (121mm) Non-label 5-3/4" (146mm) Labeled	14" (356mm)	1-3/8" (35mm) on narrow side. 2-5/8" (67mm) on wide side.	5/8" (16mm)	1/2"* (13mm)	DIE MITERED with four (4) concealed tabs interlocking head and jambs
FE14	8' 0" x 10' 0" (2439mm x 3048mm)	4-3/4" (121mm) Non-label 5-3/4" (146mm) Labeled	14" (356mm)	1-3/8" (35mm) on narrow side. 2-5/8" (67mm) on wide side.	5/8" (16mm)	1/2"* (13mm)	DIE MITERED with four (4) concealed tabs interlocking head and jambs

\*Except 5-3/4" (146mm) depth, which is 7/16" (11mm)

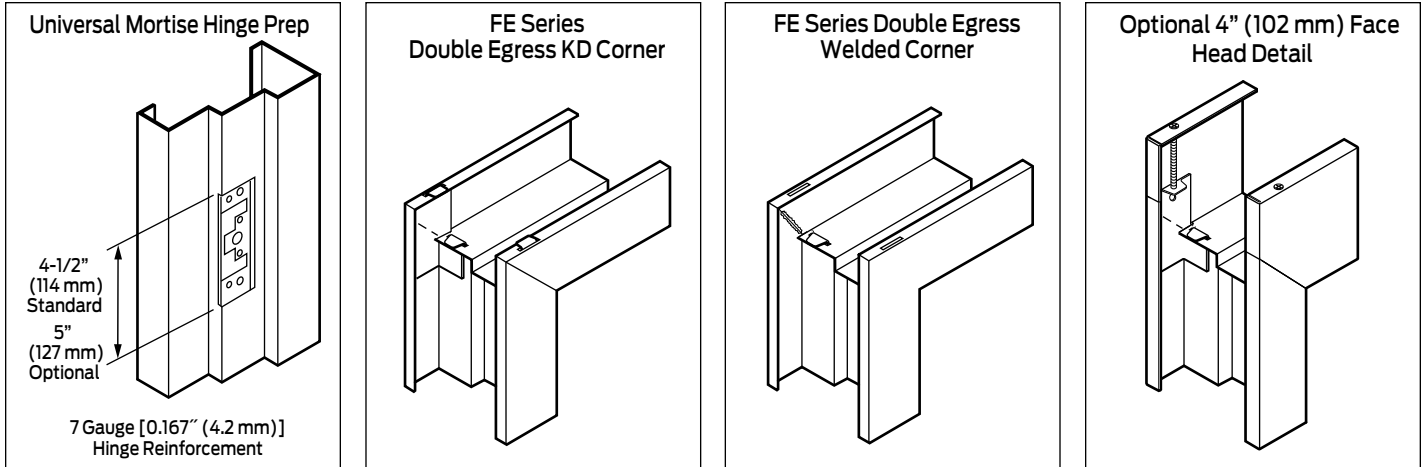

**General notes**

1. Variations in jamb depths available in 1/8" (3mm) increments.
2. All FE Series frames are supplied standard with masonry and wire and weld-in base anchors. Anchors are designed for maximum wall/frame engagement and installation flexibility. Weld-in stud anchors are an optional add.
3. FE Series frames are to be installed as part of the wallframing sequence.
4. Depending on environmental and usage conditions, the

- steel can be either cold rolled or galvanized. Galvanized steel is recommended for all exterior applications.
5. Tabs in Rabbeted area should be bent outward, not inward, during assembly (as shown).
  1. FE Series with 4" heads are used mainly in masonry applications when 2" face heads do not match block coursing.

**Frame options**

Series	Frame profile	Corner connections		4" (102mm) Heads
		KD (Knock-down)	SUA (Set-up & weld)	
FE16	Typically for walls less than 3-3/4" (95mm) thickness or greater	KD assembly, slots, and tabs, must be assembled by distributor prior to installation.	Available from Steelcraft when specified in accordance with ANSI A250.8-2003 (SDI100)	Die-mitered for use with 2" (51mm) face double rabbet jambs. Available when specified for KD or SUA applications. For KD assembly, must be assembled by distributor prior to installation.
FE14	Typically for walls less than 3-3/4" (95mm) thickness or greater	KD assembly, slots, and tabs, must be assembled by distributor prior to installation.	Available from Steelcraft when specified in accordance with ANSI A250.8-2003 (SDI100)	Die-mitered for use with 2" (51mm) face double rabbet jambs. Available when specified for KD or SUA applications. For KD assembly, must be assembled by distributor prior to installation.

N/A - Not Available

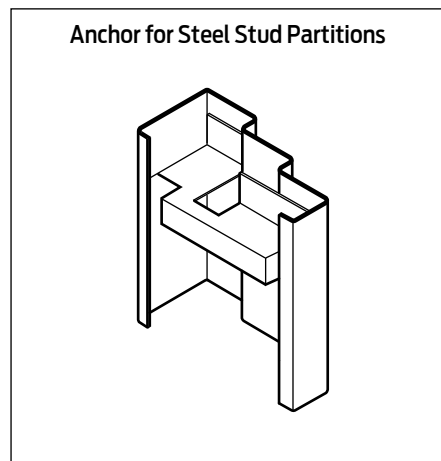
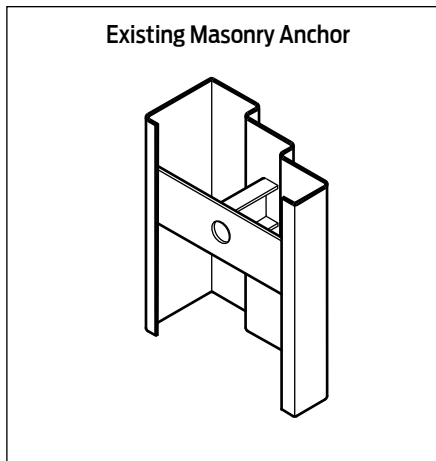
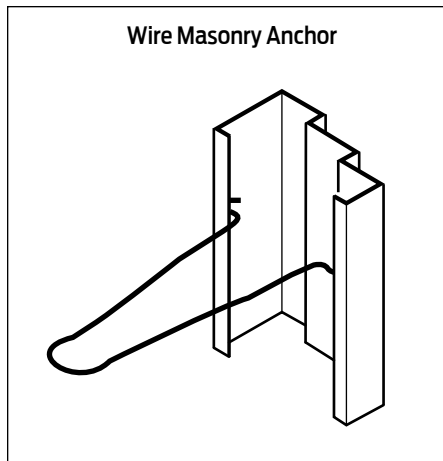

## Anchoring and installation notes

1. **FE Series double egress frames** are supplied standard with masonry wire and fixed base anchors. Anchors are designed for maximum wall/frame engagement, and installation flexibility. Optional weld-in jamb anchors are available as an add.
2. **For anchoring applications, refer to the Frames: Anchoring systems section of this manual.**
3. **Installation caution notice: Grouted frames:**
  - When temperature conditions necessitate an additive to be used in the mortar to prevent freezing, the contractor installing the frames must coat the inside of frames in the field with a corrosion resistant coating per SDI 105.
  - When frames are to be grouted full, silencers must be field installed prior to grouting.
  - Steel frames, including fire rated frames, do not require grouting. Grouting is not recommended for frames in drywall.
4. **Special frame anchorage:** Frame anchor details shown on this sheet are applicable To Formatable Egress frames with 2" (50mm) faces. Anchor details will vary with frame profile changes.
5. Installation shall conform to the published Steelcraft installation instructions, *SDI 105 Recommended Installation Instructions for Steel Frames*.
  1. All fire rated frames must be installed in accordance with NFPA Pamphlet 80 and the *Authority Having Jurisdiction*.

## Framing applications

Series	Steel type	Building type	Usage frequency <sup>1</sup>	KD <sup>4</sup> Corner	SUA <sup>5</sup> Corner	Applications
FE16	Non-Galvannealed <sup>2</sup>	Institutional and Commercial	Heavy to extra heavy duty	✓	✓	Typical building conditions
	Galvannealed <sup>3</sup>					High humidity and/or weather exposure
FE14	Non-Galvannealed <sup>2</sup>	Institutional and Commercial	Extra heavy to maximum duty	✓	✓	Typical building conditions
	Galvannealed <sup>3</sup>					High humidity and/or weather exposure

<sup>1</sup> Usage frequency is based on ANSI A250.8-2003

<sup>2</sup> Commercial quality carbon steel

<sup>3</sup> Reinforcements for galvannealed frames are also galvannealed

<sup>4</sup> Knock-Down for field assembly prior to installation

<sup>5</sup> Set-up and Welded for installation as a pre-welded unit



## About the product

The DE Series double egress frames meet all the design parameters of conventional double egress frames and is specified when cross corridor openings have the additional requirements of maximized clear opening width. The unique design of the DE Series Frame **allows for the use of swing clear hinges**. This must be considered if your local building code has a minimum clear opening width requirement, typically 44".

## Installation

1. Installation shall conform to the published Steelcraft installation instructions, ANSI A250.11-2001 (formerly SDI 105) *Recommended Erection Instructions for Steel Frames and HMMA 840*.
1. Fire Rated Assemblies must be in accordance with NFPA Pamphlet 80. The *Authority Having Jurisdiction* is the final authority in issues related to the installation and use of installed Fire Rated Doors. The *Authority Having Jurisdiction* is the final authority in issues related to the installation and use of installed Fire Rated Doors.

## Features and benefits

Steelcraft DE Series double egress frames offer the following unique features, which enhance long term functionality and durability:

1. **Die-mitered corner connection** insures tight fit and assembly. Frame must be welded by prior to installation.
2. **Patented universal hinge preparations** allow for easy field conversion from standard weight .134" (3.3mm) thick hinges to heavy weight .180" (4.7mm) hinges.
3. **Factory prepared** for field installed silencers.
4. **Factory applied baked-on rust inhibiting primer** in accordance with ANSI A250.10-1998 (R2004).
2. **Unique design to meet clear width corridor applications.**

## Specification compliance

1. Overall frame construction for the Steelcraft DE16 and DE14 Series double egress frames meet and exceed the requirements of ANSI A250.8-2003 (commonly referred to as SDI-100).
2. Hardware preparations and reinforcements are in accordance with ANSI A250.6-2003. Locations are in accordance with ANSI/DHI A115 unless otherwise stated.

## Fire ratings

The DE Series double egress frames meet the broadest fire rating requirements. They are listed for installations requiring compliance to both neutral pressure testing (ASTM E152 and UL 10B) and positive pressure standards (UL 10C). Refer to the **Fire Rated Section** of this manual for particular listings.

## Applications

DE Series double egress frames are typically installed in wall construction types as defined in the chart below:

### Frame applications

Profile	Steel thickness	Wall construction	Typical wall anchors
DE16	16 Gauge [0.053" (1.3mm)]	Wood or steel stud	Weld-in stud anchor
DE16	16 Gauge [0.053" (1.3mm)]	Masonry	Wire masonry
DE16	16 Gauge [0.053" (1.3mm)]	Existing masonry	Bolted through door rabbet
DE14	14 Gauge [0.067" (1.7mm)]	Wood or steel stud	Weld-in stud anchor
DE14	14 Gauge [0.067" (1.7mm)]	Masonry	Wire masonry
DE14	14 Gauge [0.067" (1.7mm)]	Existing masonry	Bolted through door rabbet

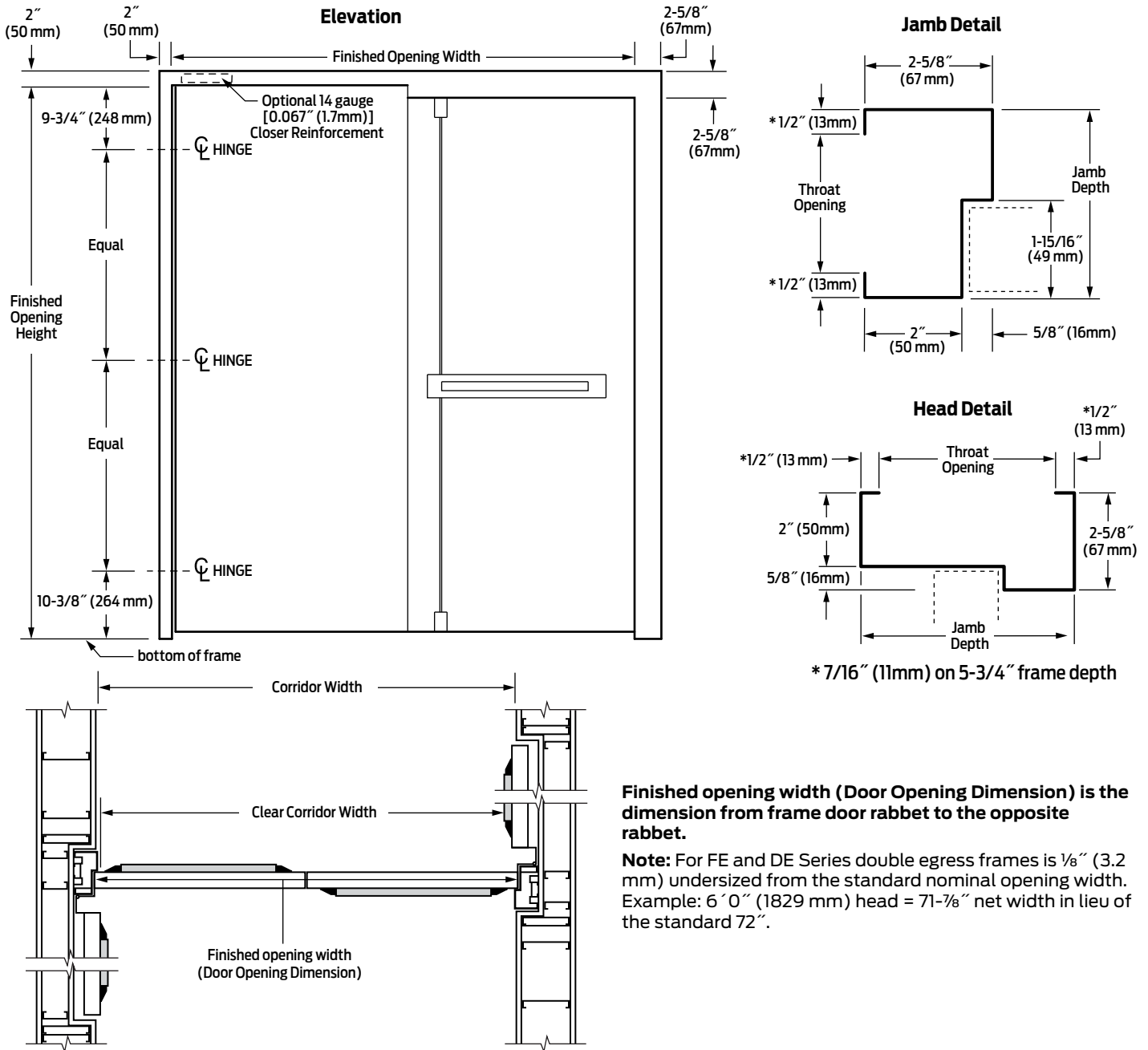

**Finished opening width (Door Opening Dimension) is the dimension from frame door rabbet to the opposite rabbet.**

**Note:** For FE and DE Series double egress frames is 1/8" (3.2 mm) undersized from the standard nominal opening width. Example: 6' 0" (1829 mm) head = 71-7/8" net width in lieu of the standard 72".

Frame sizing options

Series	Maximum opening size	Jamb depth availability (profile)		Standard profile dimensions (variations available)			Corners
		2 step jambs x 2 step heads		Face	Stop	Returns	
		Minimum	Maximum				
							Standard
DE16	8' 0" x 10' 0" (2439mm x 3048mm)	5-3/4" (146mm) Labeled or Non-label	14" (356mm)	2" (50mm) on narrow side. 2-5/8" (67mm) on wide side.	5/8" (16mm)	1/2"* (13mm)	Must be welded prior to installation
DE14	8' 0" x 10' 0" (2439mm x 3048mm)	5-3/4" (146mm) Labeled or Non-label	14" (356mm)	2" (50mm) on narrow side. 2-5/8" (67mm) on wide side.	5/8" (16mm)	1/2"* (13mm)	Must be welded prior to installation

\*Except 5-3/4" (146mm) depth, which is 7/16" (11mm)

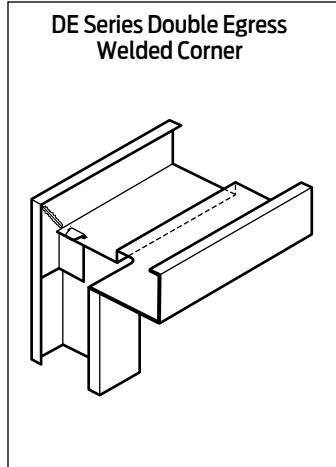
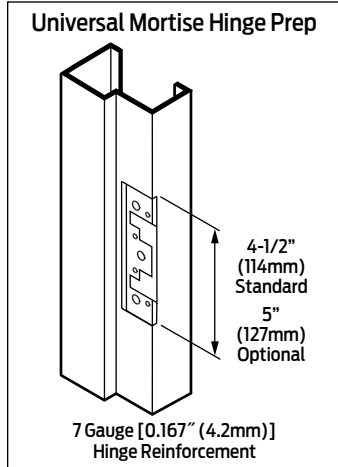

## General notes

1. Variations in jamb depths available in 1/8" (3mm) increments.
  2. Due to the configuration of narrow hinge jambs mating to wider heads, DE Series frames are supplied set-up and welded only.
  3. All DE Series frames are supplied standard with masonry wire and weld-in base anchors. Anchors are designed for maximum wall/frame engagement and installation flexibility. Optional weld-in jamb anchors are available as an add.
  4. DE Series frames are to be installed as part of the wall framing sequence.
  5. Depending on environmental and usage conditions, the steel can be either cold rolled or galvanized.
1. Tabs in rabbeted area should be bent outward, not inward, during assembly (as shown).



**Note:**

Together with the use of Swing-Clear type hinges, the DE Series double egress 2 Step hinge jambs will provide additional cross-corridor width between jambs:

- removes the thickness of the door from the opening, even when at 90°
- changes the Pivot Point of the door
- can increase the clear opening width by 5-1/4" (133mm)

### Frame options

Series	Frame profile	Corner connections		4" (102mm) Heads
		KD (Knock-down)	SUA (Set-up & weld)	
DE16	Typically for walls 3-3/4" (95mm) thickness or greater	NOT AVAILABLE FORKD INSTALLATION Die-mitered corners, must be welded by distributor prior to installation	Available from Steelcraft when specified in accordance with ANSI A250.8-2003 (SDI100)	Available when specified. Must be welded prior to installation
DE14	Typically for walls 3-3/4" (95mm) thickness or greater	NOT AVAILABLE FORKD INSTALLATION Die-mitered corners, must be welded by distributor prior to installation	Available from Steelcraft when specified in accordance with ANSI A250.8-2003 (SDI100)	Available when specified. Must be welded prior to installation

**Note:**

1. Hinge Jambs for DE Series double egress frames are single rabbet sections and are a smaller jamb depth than the head.
2. The jamb depth of the hinge jambs is shown in the chart below.
3. **ALWAYS ORDER DE Series frames BY THE FRAME DEPTH OF THE HEAD.** Steelcraft will manufacture the jambs as required.

Head		Jamb	
Frame depth	Throat opening	Jamb depth	Throat opening
5-3/4" (146mm)	4-7/8" <sup>1</sup> (124mm <sup>1</sup> )	3-27/32" (98mm)	2-31/32" (75mm)
6-3/4" (171mm)	5-3/4" (146mm)	4-11/32" (110mm)	3-11/32" (85mm)
7-3/4" (197mm)	6-3/4" (171mm)	4-27/32" (123mm)	3-27/32" (98mm)
8-3/4" (222mm)	7-3/4" (197mm)	5-11/32" (136mm)	4-11/32" (110mm)

15-3/4" (146mm) jamb depth frame has 7/16" (11mm) backbends. All others have 1/2" (13mm) backbends.



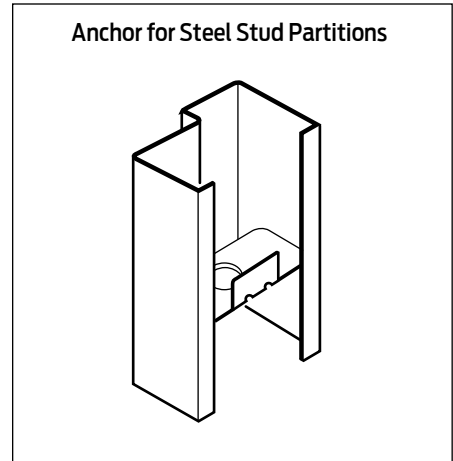
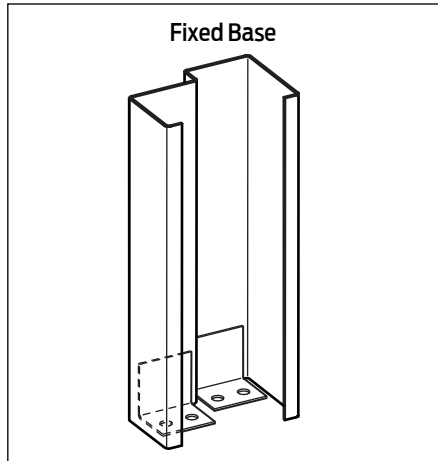
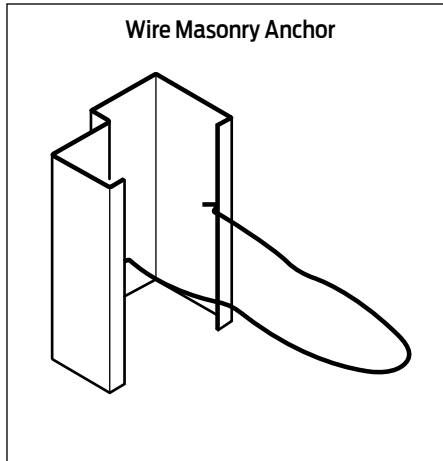

### Anchoring and installation notes

1. **DE Series double egress frames** are supplied standard with masonry wire and fixed base anchors. Anchors are designed for maximum wall/frame engagement and installation flexibility. Optional weld-in jamb anchors are available as an add.
2. **For anchoring applications, refer to the Frames: Anchoring systems section of this manual.**
3. **Installation caution notice: Grouted frames:**
  - When temperature conditions necessitate an additive to be used in the mortar to prevent freezing, the contractor installing the frames must coat the inside of frames in the field with a corrosion resistant coating per SDI 105.
  - When frames are to be grouted full, silencers must be field installed prior to grouting.
  - Steel frames, including fire rated frames, do not require grouting. Grouting is not recommended for frames in drywall.

4. **Special frame anchorage:** Frame anchor details shown on this sheet are applicable To Formatable Egress frames with 2" (50mm) faces. Anchor details will vary with frame profile changes.
5. Installation shall conform to the published Steelcraft installation instructions, *SDI 105 Recommended Installation Instructions for Steel Frames*.
  1. All fire rated frames must be installed in accordance with NFPA Pamphlet 80 and the *Authority Having Jurisdiction*.

### Framing applications

Series	Steel type	Building type	Usage frequency <sup>1</sup>	KD <sup>4</sup> Corner	SUA <sup>4</sup> Corner	Applications
DE16	Non-Galvannealed <sup>2</sup>	Institutional and Commercial	Heavy to extraheavy duty	N/A	✓	Typical building conditions
	Galvannealed <sup>3</sup>					High humidity and/or weather exposure
DE14	Non-Galvannealed <sup>2</sup>	Institutional and Commercial	Extra heavy to maximum duty	N/A	✓	Typical building conditions
	Galvannealed <sup>3</sup>					High humidity and/or weather exposure

<sup>1</sup> Usage frequency is based on ANSI A250.8-2003

<sup>2</sup> Commercial quality carbon steel

<sup>3</sup> Reinforcements for galvannealed frames are also galvannealed

<sup>4</sup> Knock-Down for field assembly prior to installation

N/A = Not available





## About the product

Steelcraft's DW Series Drywall frames are designed for light to heavy duty applications in both commercial and institutional buildings. They can be installed in rough openings after the wall has been constructed and finished. They are installed in virtually all types of buildings in all interior drywall partition locations using baseboards. To accommodate the installation of the DW Series frames on finished drywall construction, they are supplied with a KD (knock-down) corner for quick installation.

## Installation

1. Installation shall conform to the published Steelcraft installation instructions, ANSI A250.11-2001 (formerly SDI 105) *Recommended Erection Instructions for Steel Frames and HMMA 840*.
1. Fire Rated Assemblies must be in accordance with NFPA Pamphlet 80. The Authority Having Jurisdiction is the final authority in issues related to the installation and use of installed Fire Rated Doors.

## Features and benefits

Steelcraft DW Series Drywall frames include unique features which enhance long-term functionality and durability:

1. **Quick and flexible installation** of Steelcraft's DW Series Drywall frames facilitates their installation in minutes and they can be relocated without damage to the frame.
2. **Die-mitered corner connections** of the DW Series Drywall Frame corners lock together once the frame is installed. The tab/lock design:
  - a. prevents the head from rising
  - b. keeps the head and jamb members in alignment
  - c. keeps the miter tight
  - d. includes wedge-lock corner clips. Screws are included to secure miter.
3. **Adjustable base anchors** allow for attachment directly to the wall sill runner, and facilitates installation adjustment when the floor is not level.
4. **Factory prepared** for field installed silencers.
2. **Factory applied baked-on rust inhibiting primer** in accordance with ANSI A250.10-1998 (R2004).

## Specification compliance

1. Overall frame construction for the Steelcraft DW Series Drywall frames meet and exceed the requirements of ANSI A250.8-2003 (SDI-100).
3. Hardware preparations and reinforcements are in accordance with ANSI A250.6-2003. Locations are in accordance with ANSI/DHI A115 unless otherwise stated.

## Fire ratings

The DW Series Drywall frames meet the broadest fire rating requirements. They are listed for installations requiring compliance to both neutral pressure testing (ASTM E152 and UL 10B) and positive pressure standards (UL 10C). Refer to the **Fire Rated Section** of this manual for particular listings.

## Applications

Steelcraft DW Series Drywall frames are typically installed in wall construction types as defined in the chart below:

### Frame applications

Profile	Steel thickness	Wall construction	Typical wall anchors
DW16	16 Gauge [0.053" (1.3mm)]	Drywall partitions with wood or steel stud	Compression jamb anchor(s) with adjustable Base Anchor Systems
DW14	14 Gauge [0.067" (1.7mm)]	Drywall partitions with wood or steel stud	Compression jamb anchor(s) with adjustable Base Anchor Systems

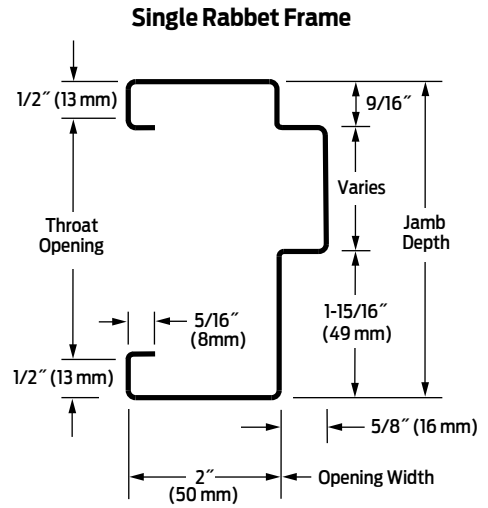
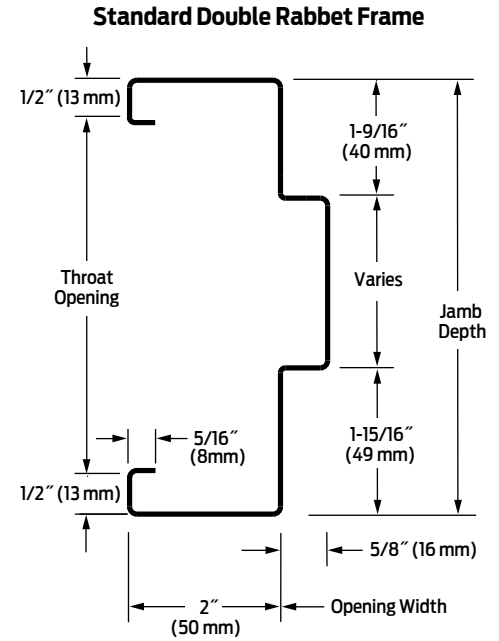
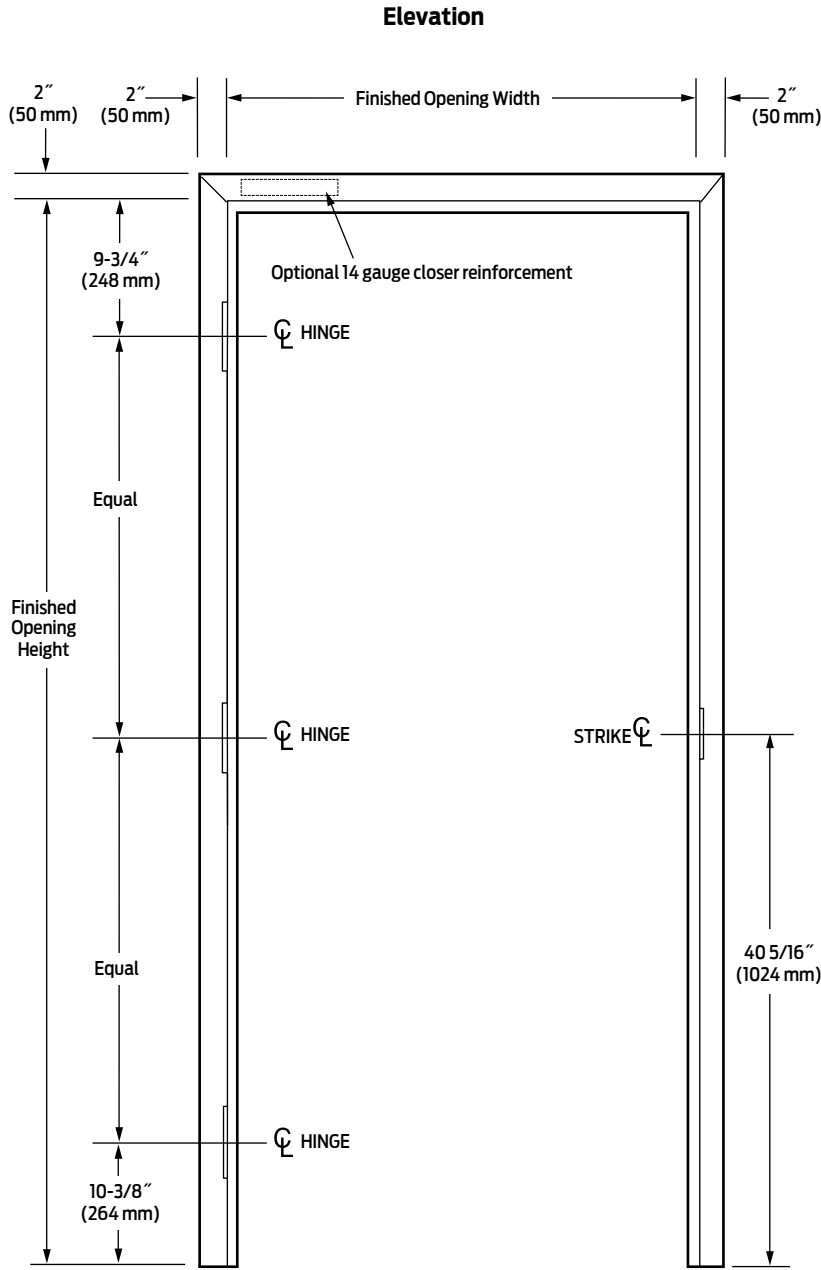

Frame sizing options

Series	Maximum opening size		Jamb depth availability (profile)				Standard profile dimensions (variations available)			Corners
	Single	Pair	Single rabbet		Double rabbet		Face	Stop	Returns	
			Minimum	Maximum	Minimum	Maximum				Standard
DW16	4'0" x 9'0" (1219mm x 2743mm)	8'0" x 9'0" (2439mm x 2743mm)	3-1/4" (83mm)	4-3/8" (111mm)	4-1/2" (114mm)	14-3/4" (375mm)	2" (51mm)	5/8" (16mm)	1/2" (13mm)	DIE MITERED Wedge Lock Corner with interlocking soffit tab
DW14	4'0" x 9'0" (1219mm x 2743mm)	8'0" x 9'0" (2439mm x 2743mm)	3-1/4" (83mm)	4-3/8" (111mm)	4-1/2" (114mm)	14-3/4" (375mm)	2" (51mm)	5/8" (16mm)	1/2" (13mm)	DIE MITERED Wedge Lock Corner with interlocking soffit tab

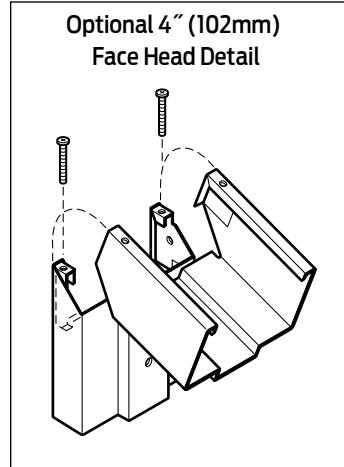
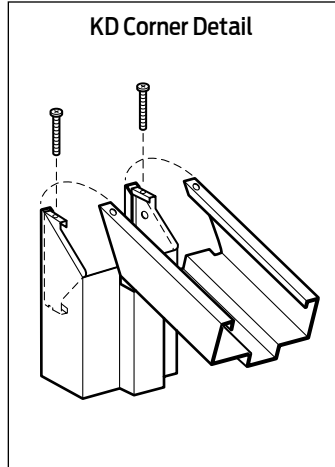
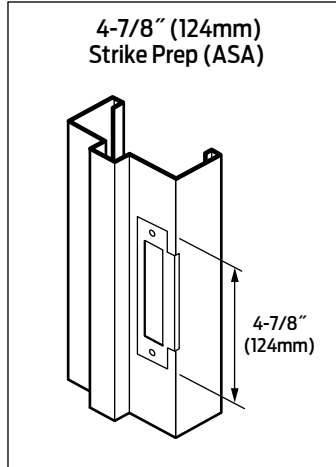
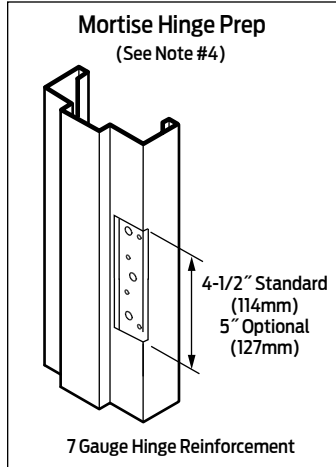

**General notes**

1. Variations in jamb depths available in 1/8" (3mm) increments.
2. All DW Series frames are supplied standard with field adjustable compression anchors located near the top of each jamb and adjustable base anchors with twist-in strap base anchors in each jamb.
  - a. The compression anchor can be easily adjusted with a screw driver or power driver.
  - b. The lock-in base anchor system is provided for attachment directly to the floor runner (sill) when using wall baseboards.
3. Depending on environmental and usage conditions, the steel used can be either cold rolled or galvanized. Galvanized steel is recommended in areas of high moisture.
4. DW Series frames are supplied standard with 4-1/2" standard duty hinge preps. Optional universal 4-1/2" or 5" hinge preps are available.
1. DW Series with 4" heads are used mainly when installed in close proximity to a F Series or MU Series frame installed with a 4" head.

**Frame options**

Series	Frame profile		Corner connections				4" (102mm) Heads
			KD (Knock-down)		SUA (Set-up & weld)		
	Single rabbet	Double rabbet	Single rabbet	Double rabbet	Single rabbet	Double rabbet	
DW16	Typically for walls less than 3-3/4" (95mm) thick. Minimum wall thickness = 2" (51mm)	Typically for walls less than 3-3/4" (95mm) thickness or greater	Factory Die-Mitered, Soffit Tab included. Corner clip assembly screws required on labeled frames.	Factory Die-Mitered, Soffit Tab included. Corner clip assembly screws required on labeled frames.	N/A	N/A	Die-mitered for use with 2" (51mm) face jambs. Corner Clip assembly screws required.
DW14							

N/A - Not Available

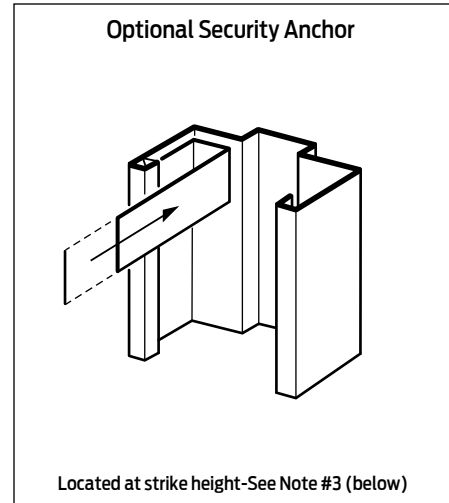
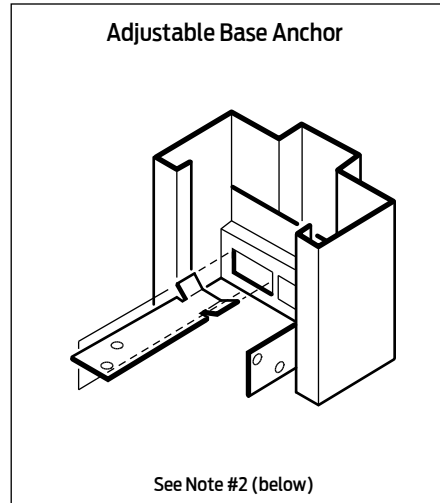
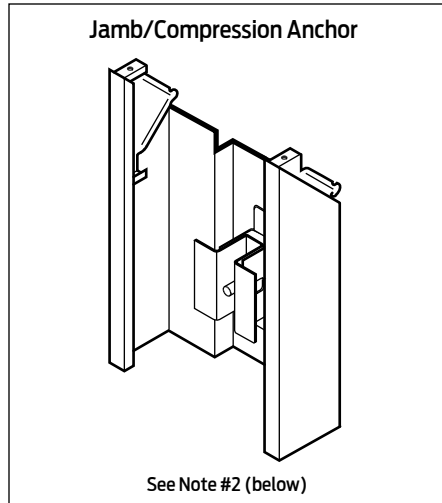

## Anchoring and installation notes

1. **DW16 Series Drywall frames** are supplied standard with field adjustable compression anchors in each jamb and adjustable base anchors. DW Series frames are designed especially for use in installations using wall baseboards.
2. **For anchoring applications, refer to the Frames: Anchoring systems section of this manual**
  - Masonry wall: Not recommended
3. **Optional security anchor:** Security anchors are recommended in frames over 8'0" (2438mm) high or in frames installed in areas where security is a priority. Locate the security anchor immediately above or below the strike reinforcements, and on both faces of the jamb. Anchors may be used in both the strike and hinge jamb. Also recommend

to be used in the head of frames for pairs.

4. **Grouting of the DW Series frames is not recommended.**
5. **Installation Caution Notice:** After the frame pieces are slid over the wall, the frame is squared by adjusting the compression anchor screws located in the soffit of the jambs. Turning the screw clockwise will tighten the frame. Check to insure the opening is plumb.
6. Installation shall conform to the published Steelcraft installation instructions, *SDI 105 Recommended Installation Instructions for Steel Frames*.
1. All fire rated frames must be installed in accordance with NFPA Pamphlet 80 and the *Authority Having Jurisdiction*.

## Framing applications

Series	Steel type	Building type	Opening	Usage frequency <sup>1</sup>	KD <sup>4</sup> Corner	SUA Corner	Applications
DW16	Non-Galvannealed <sup>2</sup>	Institutional and Commercial	Interior	Heavy to extraheavy duty	✓	N/A	Typical building conditions with base boards
	Galvannealed <sup>3</sup>						
DW14	Non-Galvannealed <sup>2</sup>	Institutional and Commercial	Interior	Extra heavy to maximum duty	✓	N/A	Typical building conditions with base boards
	Galvannealed <sup>3</sup>						

<sup>1</sup> Usage frequency is based on ANSI A250.8-2003

<sup>2</sup> Commercial quality carbon steel

<sup>3</sup> Reinforcements for galvannealed frames are also galvannealed

<sup>4</sup> Knock-Down for field assembly prior to installation

N/A = Not available



## About the product

Steelcraft's K Series Drywall frames are designed for light to heavy duty applications in both commercial and institutional buildings. They can be installed in rough openings after the wall has been constructed and finished. They are installed in virtually all types of buildings in all interior drywall partition locations not using baseboards. To accommodate the installation of the K Series Drywall frames on finished drywall construction, they are supplied with a KD (knock-down) corner for quick installation.

## Installation

1. Installation shall conform to the published Steelcraft installation instructions, ANSI A250.11-2001 (formerly SDI 105) *Recommended Erection Instructions for Steel Frames*.
1. Fire Rated Assemblies must be in accordance with NFPA Pamphlet 80. The *Authority Having Jurisdiction* is the final authority in issues related to the installation and use of installed Fire Rated Doors.

## Features and benefits

Steelcraft K Series Drywall frames include unique features which enhance long-term functionality and durability:

1. **Quick and flexible installation** of Steelcraft's K Series Drywall frames facilitates their installation in minutes and they can be relocated without damage to the frame.
2. **Die-mitered corner connections** of the K Series Drywall Frame corners lock together once the frame is installed. The tab/lock design:
  - a. prevents the head from rising
  - b. keeps the head and jamb members in alignment
  - c. keeps the miter tight
  - d. includes wedge-lock corner clips. Screws are supplied to secure miter.
3. **Sill attachment** is made through the face of the frame directly into the wall sill runner. The frame is supplied with factory countersunk holes for the screw attachment.
4. **Factory prepared** for field installed silencers.
2. **Factory applied baked-on rust inhibiting primer** in accordance with ANSI A250.10-1998 (R2004).

## Specification compliance

1. Overall frame construction for Steelcraft K Series Drywall frames meet the requirements of ANSI A250.8-2003(SDI 100).
3. Hardware preparations and reinforcements are in accordance with ANSI A250.6-2003. Locations are in accordance with ANSI/DHI A115 unless otherwise stated.

## Fire ratings

The K Series Drywall frames meet the broadest fire rating requirements. They are listed for installations requiring compliance to both neutral pressure testing (ASTM E152 and UL 10B) and positive pressure standards (UL 10C). Refer to the **Fire Rated Section** of this manual for particular listings.

## Applications

Steelcraft K Series Drywall frames are typically installed in wall construction types as defined in the chart below:

### Frame applications

Profile	Steel thickness	Wall construction	Typical wall anchors
<b>K16</b>	16 Gauge [0.053" (1.3mm)]	Drywall partitions with wood or steel stud	Compression jamb anchor(s) with factory countersunk holes for screw attachment directly to the wall sill runner
<b>K14</b>	14 Gauge [0.067" (1.7mm)]	Drywall partitions with wood or steel stud	Compression jamb anchor(s) with factory countersunk holes for screw attachment directly to the wall sill runner

**Elevation**

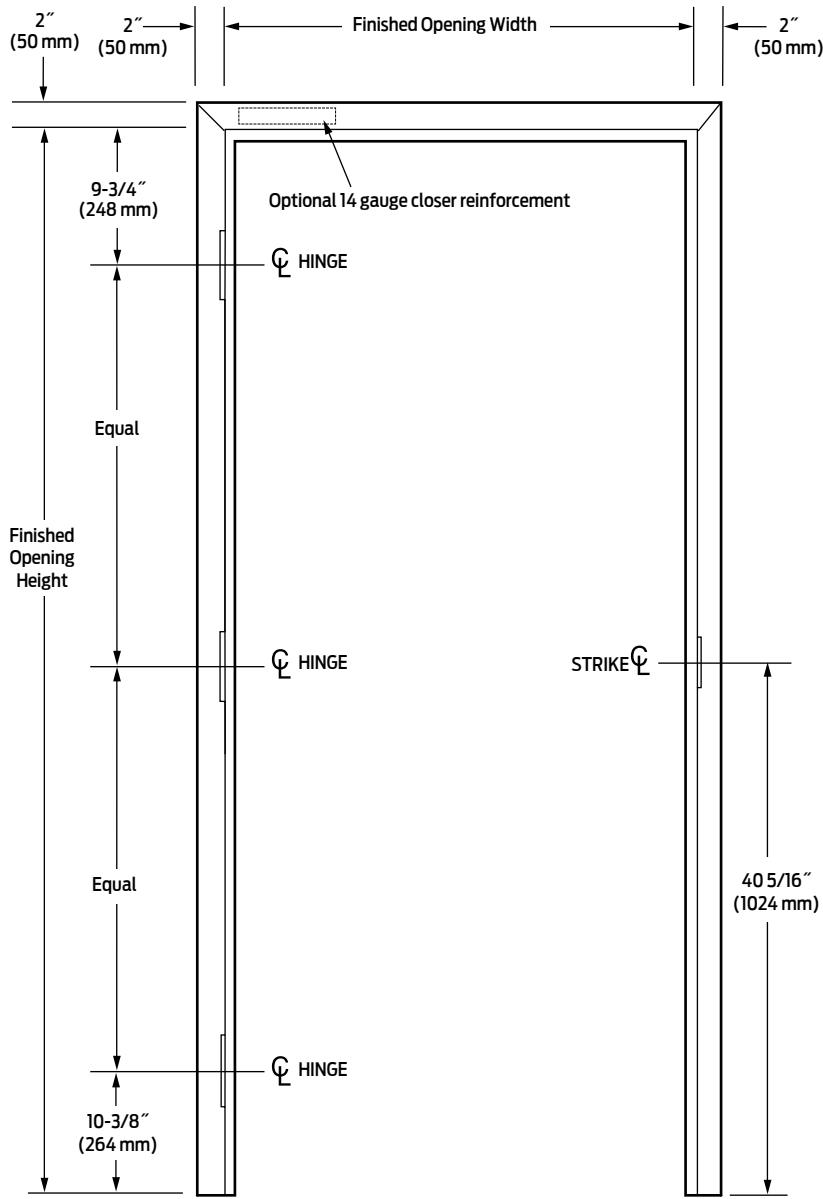

**Standard Double Rabbet Frame**

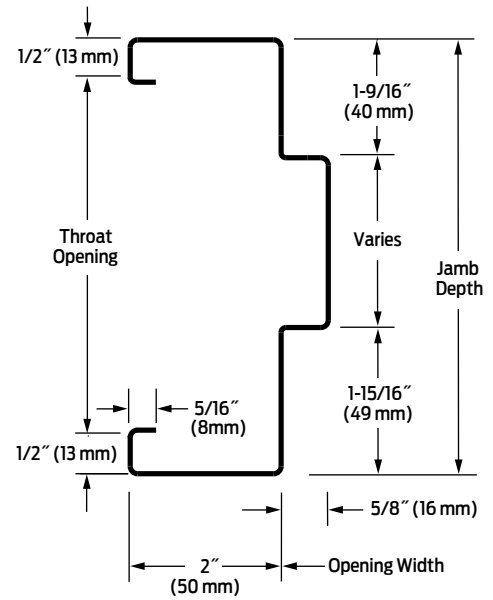

**Single Rabbet Frame**

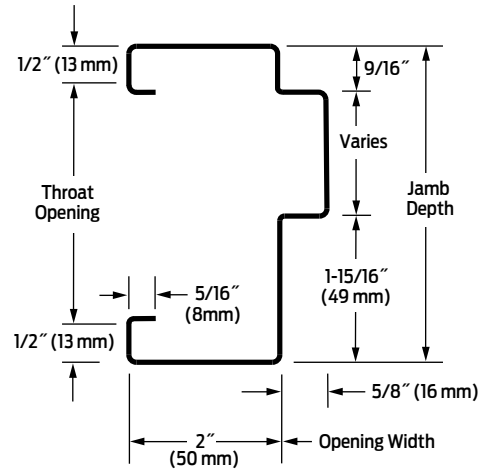

Frame sizing options

Series	Maximum opening size		Jamb depth availability (profile)				Standard profile dimensions (variations available)			Corners
	Single	Pair	Single rabbet		Double rabbet		Face	Stop	Returns	Standard
			Minimum	Maximum	Minimum	Maximum				
<b>K16</b>	4'0" x 9'0" (1219mm x 2743mm)	8'0" x 9'0" (2439mm x 2743mm)	3-1/4" (83mm)	4-3/8" (111mm)	4-1/2" (114mm)	14-3/4" (375mm)	2" (51mm)	5/8" (16mm)	1/2" (13mm)	DIE MITERED Wedge Lock Corner with interlocking soffit tab
<b>K14</b>	4'0" x 9'0" (1219mm x 2743mm)	8'0" x 9'0" (2439mm x 2743mm)	3-1/4" (83mm)	4-3/8" (111mm)	4-1/2" (114mm)	14-3/4" (375mm)	2" (51mm)	5/8" (16mm)	1/2" (13mm)	DIE MITERED Wedge Lock Corner with interlocking soffit tab

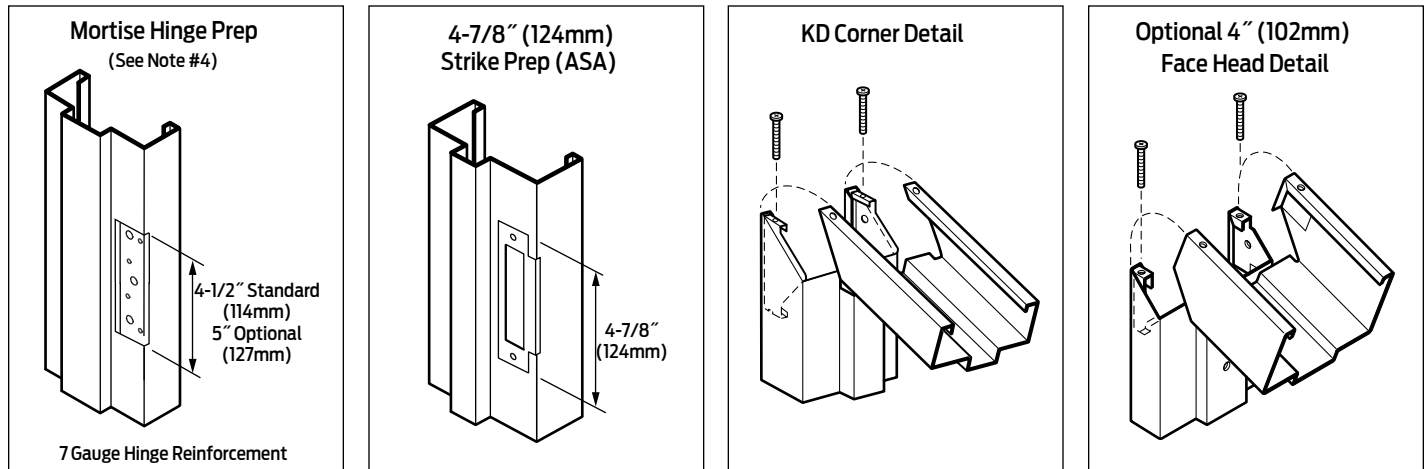

### General notes

1. Variations in jamb depths available in 1/8" (3mm) increments.
2. All K Series frames are supplied standard with field adjustable compression anchors located near the top of each jamb and factory countersunk holes for direct screw attachment to the wall runner.
  - a. The compression anchor can be easily adjusted with a screw driver or power driver.
  - b. A fastener [typically a drywall screw (by others)] is installed through the factory countersunk hole for attachment directly to the floor runner (sill) when not using wall baseboards.
3. Depending on environmental and usage conditions, the steel used can be either cold rolled or galvanized. Galvanized steel is recommended in areas of high moisture.
4. K Series frames are supplied standard with 4-1/2" standard duty hinge preps. Optional universal 4-1/2" or 5" hinge preps are available.
  1. K Series with 4" heads are used mainly when installed in close proximity to a F Series or MU Series frame installed with a 4" head.

### Frame options

Series	Frame profile		Corner connections				4" (102mm) Heads
			KD (Knock-down)		SUA (Set-up & weld)		
	Single rabbet	Double rabbet	Single rabbet	Double rabbet	Single rabbet	Double rabbet	
<b>K16</b>	Typically for walls less than 3-3/4" (95mm) thick. Minimum walls thickness = 2" (51mm)	Typically for walls less than 3-3/4" (95mm) thickness or greater	Factory Die-Mitered, Soffit Tab included. Corner clip assembly screws required on labeled frames.	Factory Die-Mitered, Soffit Tab included. Corner clip assembly screws required on labeled frames.	N/A	N/A	Die-mitered for use with 2" (51mm) face jambs. Corner Clip assembly screws required.
<b>K14</b>							

N/A - Not Available

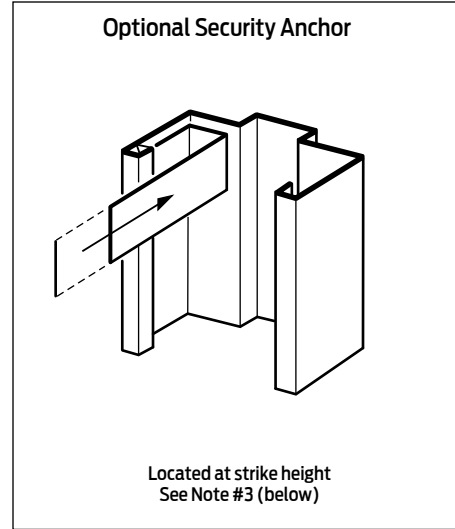
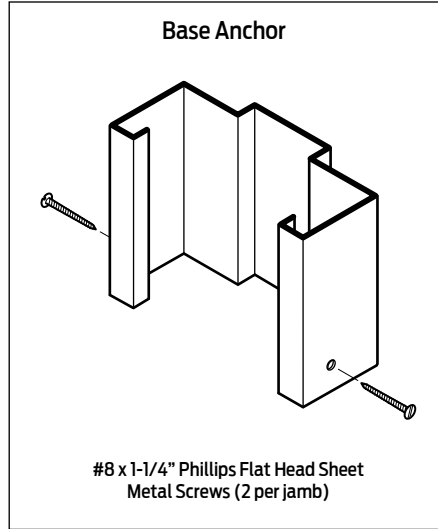
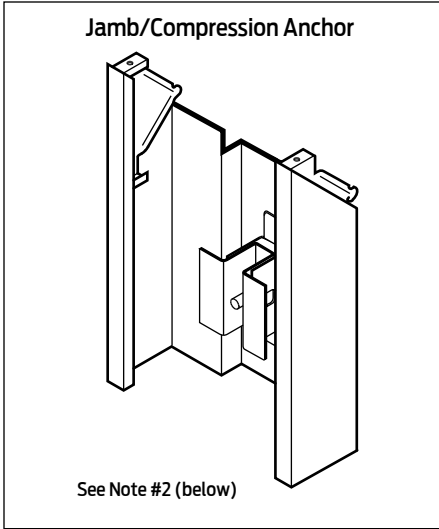

## Anchoring and installation notes

1. **K Series Drywall frames** are supplied with field adjustable compression anchors in each jamb. The base of each jamb is anchored to the wall by installing screws through the factory prepared anchor holes. K Series frames are designed especially for use in applications not using base boards.
2. **For anchoring applications, refer to the Frames: Anchoring systems section of this manual.**
3. **Optional security anchor:** Security anchors are recommended in frames over 8' 0" (2438mm) high or in frames installed in areas where security is a priority. Locate the security anchor immediately above or below the strike reinforcements, and on both faces of the jamb. Anchors may be used in both the strike and hinge jamb. Also recommend to be used in the head of the frame for pairs.
4. **Grouting of the K Series frames** is not recommended.
5. Installation shall conform to the published Steelcraft installation instructions, *SDI 105 Recommended Installation Instructions for Steel Frames*.
1. All fire rated frames must be installed in accordance with NFPA Pamphlet 80 and the *Authority Having Jurisdiction*.

## Framing applications

Series	Steel type	Building type	Opening	Usage frequency <sup>1</sup>	KD <sup>4</sup> Corner	SUA Corner	Applications
K16	Non-Galvannealed <sup>2</sup>	Institutional and Commercial	Interior	Heavy to extraheavy duty	✓	N/A	Typical building conditions where base boards are not being used
	Galvannealed <sup>3</sup>						
K14	Non-Galvannealed <sup>2</sup>	Institutional and Commercial	Interior	Extra heavy to maximum duty	✓	N/A	Typical building conditions where base boards are not being used
	Galvannealed <sup>3</sup>						

- 1 Usage frequency is based on ANSI A250.8-2003
- 2 Commercial quality carbon steel
- 3 Reinforcements for galvannealed frames are also galvannealed
- 4 Knock-Down for field assembly prior to installation

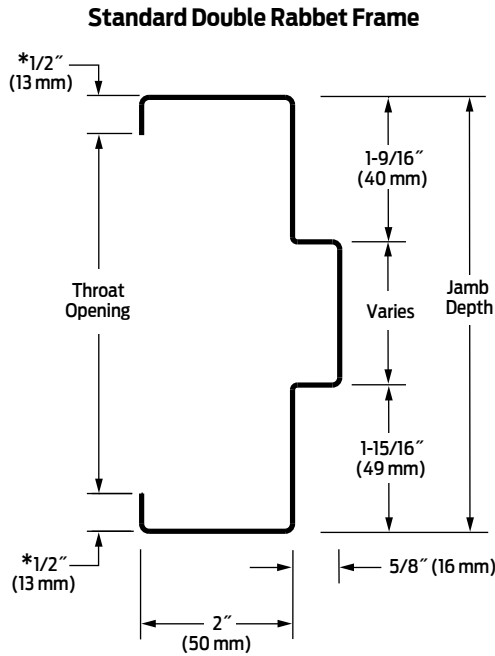

Table of contents (click below or use bookmarks)

<b>Profile variations .....55</b>	<b>Lead lined .....71</b>
Standard F Series double rabbeted ..... 55	Clips.....71
F Series ..... 56	<b>Rough buck.....72</b>
4" Heads: F Series .....57	Rough buck frames .....72
FE Series options ..... 58	<b>Applied stops .....73</b>
FE Series double egress..... 59	Applied stops.....73
DE Series .....60	<b>Hardware .....74</b>
DE Series double egress ..... 61	High frequency hinge reinforcement
Standard DW, K, and MU Series	F and FE Series .....74
double rabbeted ..... 62	Automatic operators .....74
DW, K, and MU Series ..... 63	<b>Thick doors .....75</b>
4" Head: DW, K, and MU Series ..... 64	Over 1¾" thru 3" thick.....75
Silencer preparations ..... 65	<b>Weather seals.....76</b>
<b>Dutch door ..... 66</b>	PS-074™ Surface applied weatherstrip ..... 76
Non-labeled .....66	<b>Throat filler.....77</b>
Labeled ..... 67	Rigid vinyl.....77
<b>Communicating ..... 68</b>	<b>Kerf frames .....78</b>
Communicating frames.....68	Integral.....78
<b>Hospital stops..... 69</b>	
Terminated or sanitary steps ..... 69	
<b>Head reinforcement .....70</b>	
12 Gauge full width channel ..... 70	

This page intentionally left blank

## Standard F Series double rabbeted



**KD Corner Detail**

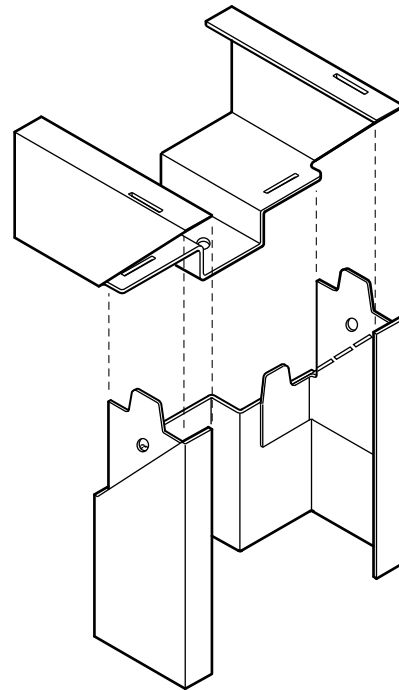

## Product: F Series unequal rabbet frames

- Gauge:** 16 Ga. (1.3mm), 14 Ga. (1.7mm)
- Jamb depth:** 4 -  $\frac{1}{2}$ " (121mm) min. thru 20" (508mm) in  $\frac{1}{8}$ " (3.2mm) increments
- Face:** Standard 2" (50mm). Non-standard 1" (25.4mm) thru 4" (102mm) in  $\frac{1}{8}$ " (3.2mm) increments
- \*Backbend:**  $\frac{7}{16}$ " (11 mm) for 5- $\frac{3}{4}$ " Frame depth
- Miter:** 45° die miter with 4 interlocking tabs for welded

**Notes:**

1. F Series (2" face) and FN Series (1" face) are available KD or welded. All other frames with custom face dimensions must be welded prior to installation.
2. Tabs in Rabbeted area should be bent outward, not inward, during assembly.

**Welded Corner**

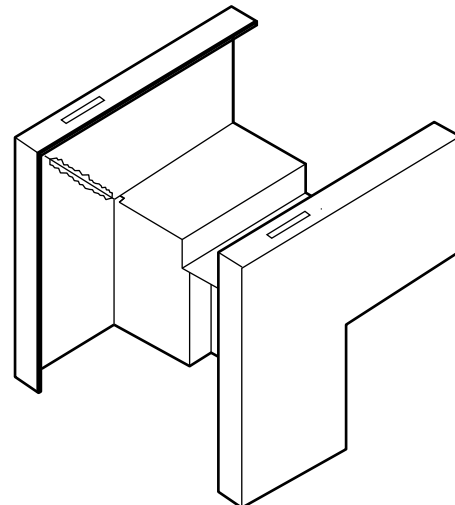

## F Series frames

**Standard Double Equal Rabbet Frame**

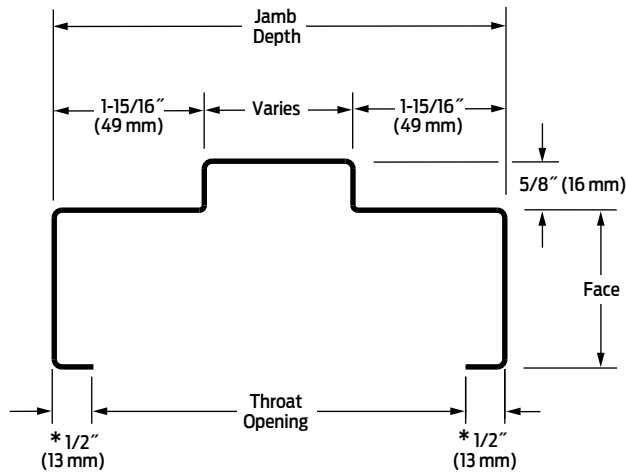

**Cased Open Frame**

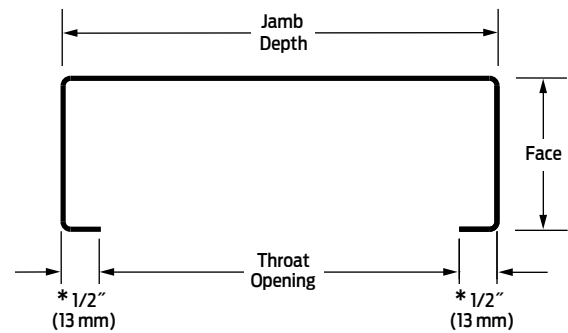

### Product: F Series equal rabbet frames

- Gauge:** 16 Ga. (1.3mm), 14 Ga. (1.7mm)
- Jamb depth:** 4-7/8" (124mm) min. thru 20" (508mm) in 1/8" (3.2mm) increments
- Face:** Standard 2" (50mm). Non-standard 1" (25.4mm) thru 4" (102mm) in 1/8" (3.2mm) increments
- \*Backbend:** 7/16" (11 mm) for 5-3/4" Frame depth
- Miter:** 45° die miter with 4 interlocking tabs for welded

### Product: F Series cased open frames

- Gauge:** 16 Ga. (1.3mm), 14 Ga. (1.7mm)
- Jamb depth:** 3" (76mm) min. thru 20" (508mm) in 1/8" (3.2mm) increments
- Face:** Standard 2" (50mm). Non-standard 1" (25.4mm) thru 4" (102mm) in 1/8" (3.2mm) increments
- \*Backbend:** 7/16" (11 mm) for 5-3/4" Frame depth
- Miter:** 45° die miter with 4 interlocking tabs for welded

**Single Rabbet Frame**

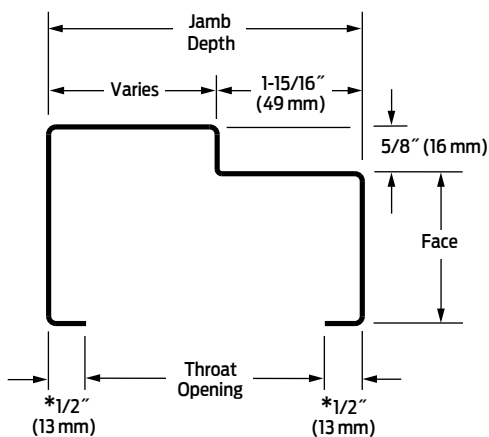

### Product: F Series single rabbet frames

- Gauge:** 16 Ga. (1.3mm), 14 Ga. (1.7mm)
- Jamb depth:** 3" (76mm) min. thru 20" (508mm) in 1/8" (3.2mm) increments
- Face:** Standard 2" (50mm). Non-standard 1" (25.4mm) thru 4" (102mm) in 1/8" (3.2mm) increments
- \*Backbend:** 7/16" (11 mm) for 5-3/4" Frame depth
- Miter:** 45° die miter with 4 interlocking tabs for welded

**Notes:**

1. F Series (2" and 1-1/2" face) and FN Series (1" face) are available KD or welded. All other frames with custom face dimensions must be welded prior to installation.

4" Heads: F Series

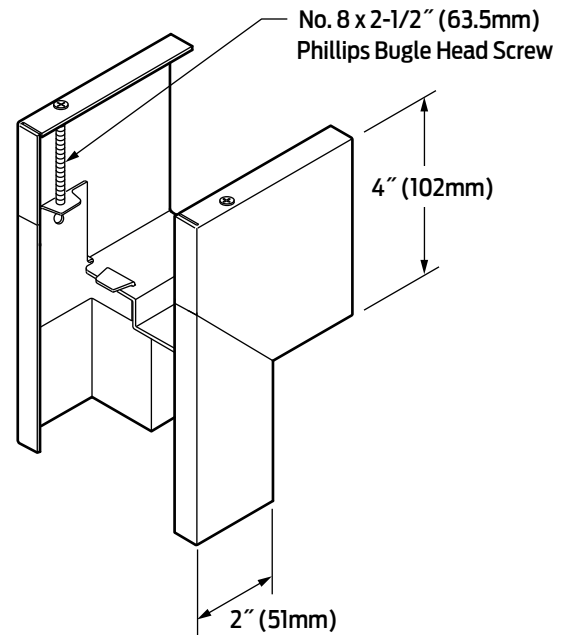
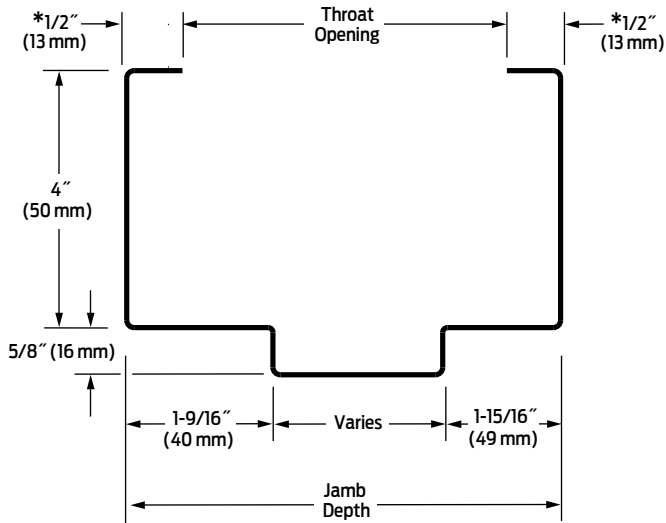

Product: F16, F14

- Profile variation:** Unequal, equal cased open
- Jamb depth:** 4-1/2" through 20" in 1/8" increments
- \*Backbend:** 7/16" (11 mm) for 5-3/4" Frame depth
- Miter:** Die mitered, tabs vary with profile variations

**Notes:**

1. Frames with 4" heads are used mainly in masonry applications when 2" face heads do not match block coursing.
2. Tabs in rabbeted area should be bent outward, not inward, during assembly (as shown).

FE Series frames options

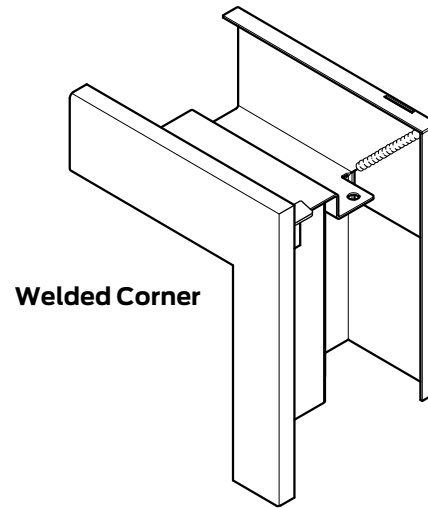
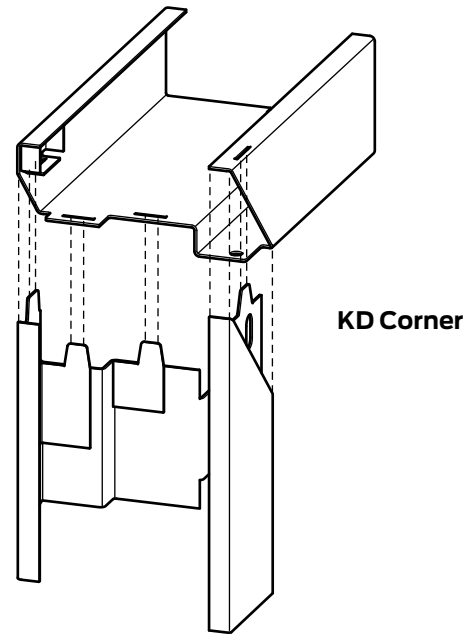
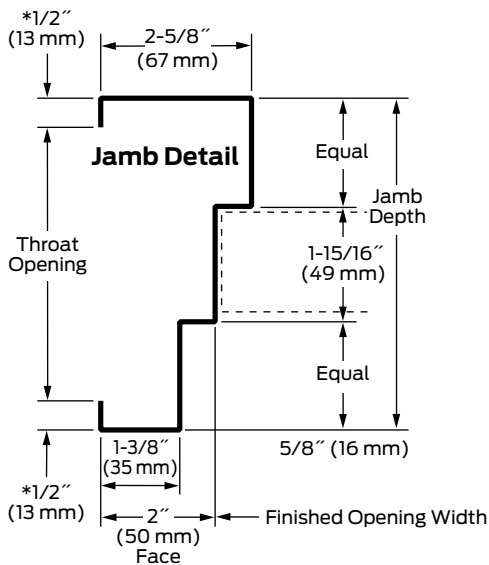
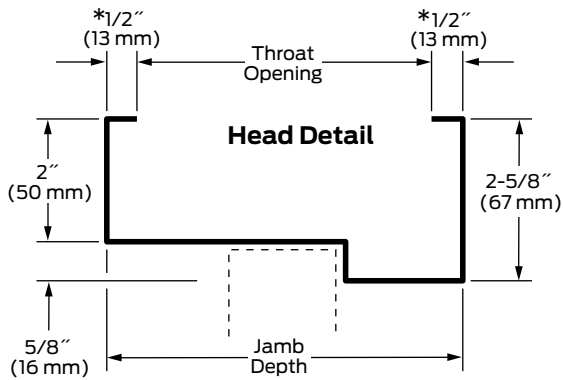

Product: FE Series Conventional double egress frames

- Gauge:** 16 Ga. (1.3 mm), 14 Ga. (1.7 mm)
- Jamb depth:** 4-3/4" (121 mm) min. thru 14" (356 mm) in 1/8" (3.2 mm) increments
- Face:** Standard 2" (50mm). Non-standard 1" (25.4 mm) thru 4" (102 mm) in 1/8" (3.2 mm) increments
- \*Backbend:** 7/16" (11 mm) for 5-3/4" Frame depth
- Miter:** 45° die miter with 4 interlocking tabs or welded

**Notes:**

1. Conventional FE Series double egress heads have a different profile from the jambs. Both heads and jambs are considered to have a 2" face.
2. Since the door is mounted on the centerline of the jamb depth, the 2" face of the jamb includes an 1-3/8" visible face and a 5/8" additional stop.
3. The door opening dimension of Steelcraft FE Series double egress frames is 1/8" undersized to insure proper door center clearances are maintained. Door widths must be adjusted accordingly when using wood or non-Steelcraft doors.
4. Tabs in Rabbeted area should be bent outward, not inward, during assembly (as shown).

## Profile variations

## FE Series double egress frames

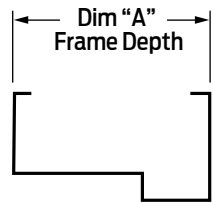

**Head Detail**  
FE Series

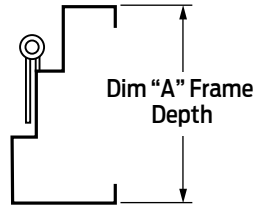

**Jamb Detail**  
FE Series

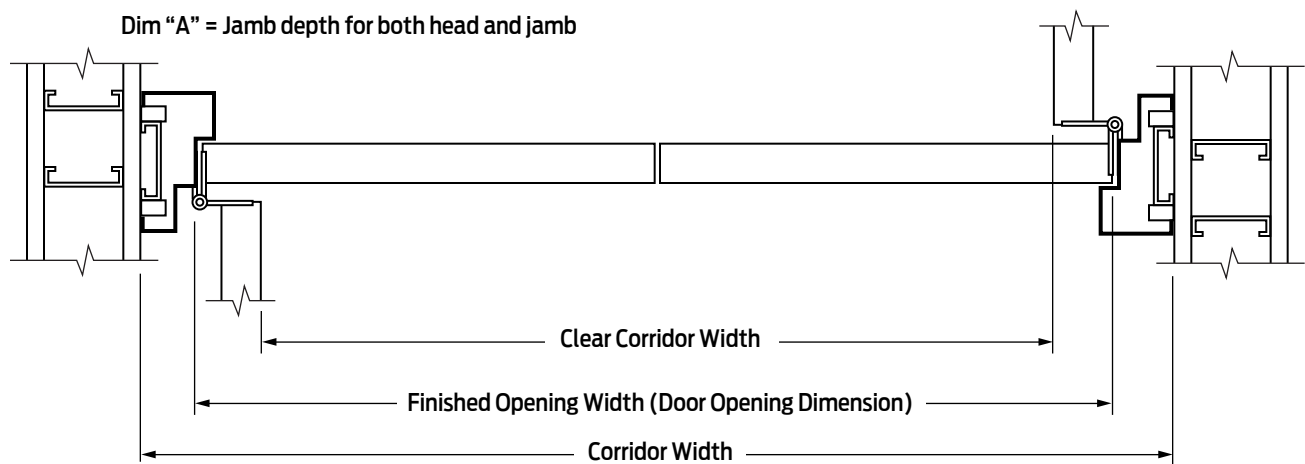

**Finished opening width (Door Opening Dimension) is the dimension from the frame door rabbet to the opposite rabbet.**

- **Note:** FE and DE Series double egress frames are 1/8" (3.2 mm) undersized from the standard nominal opening width. Example: 6' 0" (1829 mm) head = 71-7/8" net width in lieu of the standard 72".

**Clear Opening Width is the dimension between doors, measured from door face to door face, when both doors are open 90 degrees.**

- **Note:** This dimension is critical for compliance with handicapped accessibility.

**Corridor Width is the actual dimension between walls in a corridor.**

- **Note:** This dimension is critical in sizing the finished opening width (Door Opening Dimension) of the double egress frame.

## Application

FE Series double egress frames are designed for use in cross corridor application where clear opening width is not of major concern. Conventional butt or continuous hinges are used. For applications where clear opening width is critical the DE Series double egress frame is recommended.

## Purpose

FE Series double egress frames are used in cross corridor application for traffic and smoke control.

## Product availability

This product option is available for the following Steelcraft frame Series:

- FE16 and FE14 in depths from 4-3/4" (121mm) to 14" (356mm).

DE Series frames

DE Series Double Egress  
Welded Corner

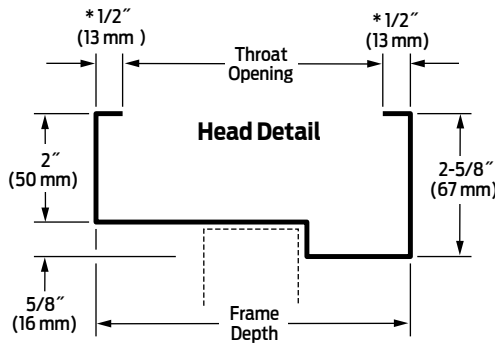
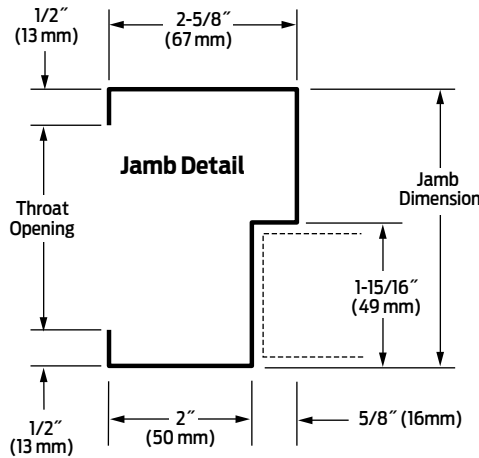
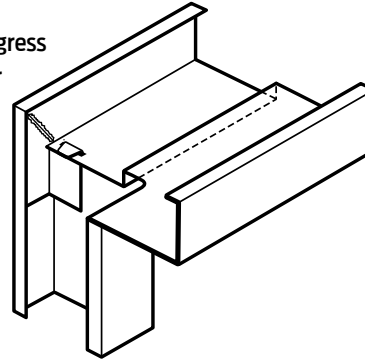

Dimension "A" head	Dimension "B" jamb
Frame depth	Jamb dimension
4-3/4"	3-11/32"
5-1/4"	3-19/32"
5-3/4"	3-27/32"
6-1/4"	4-3/32"
6-3/4"	4-11/32"
7-1/4"	4-19/32"
7-3/4"	4-27/32"
8-1/4"	5-3/32"
8-3/4"	5-11/32"
9-1/4"	5-19/32"
9-3/4"	5-27/32"
10-1/4"	6-3/32"
10-3/4"	6-11/32"

**Note:** When ordering DE Series frames, Dimension "A" specifies the frame jamb depth.

Product: DE Series double egress frames for clear width corridor applications

- Gauge:** 6 Ga. (1.3mm), 14 Ga. (1.7mm)
- Jamb depth:** 4-3/4" (121mm) min. thru 14" (356mm) in 1/8" (3.2mm) increments
- Face:** Standard 2" (50mm). Non-standard 1" (25.4mm) thru 4" (102mm) in 1/8" (3.2mm) increments
- \*Backbend:** 7/16" (11 mm) for 5-3/4" Frame depth
- Miter:** 45° die miter be welded prior to most installation

**Notes:**

1. **Face dimensions** on the DE Series frames are 2" faces for on both heads and jambs.
2. Frame depth varies for head to jambs. This variation allows for larger clear opening widths for handicapped accessibility.
  - **Frame depth (head):** This is the jamb depth of the head and is the size specified when ordering.
  - **Jamb dimension (jamb):** This is the actual jamb depth of the vertical frame member. This dimension is not specified when ordering. Refer to table for additional clarification.
3. The door opening dimension of Steelcraft DE Series double egress frames is 1/8" undersized to insure proper door center clearances are maintained. Door widths must be adjusted accordingly when using wood or non-Steelcraft doors.
4. Tabs in rabbeted area should be bent outward, not inward, during assembly (as shown).



## DE Series double egress frames

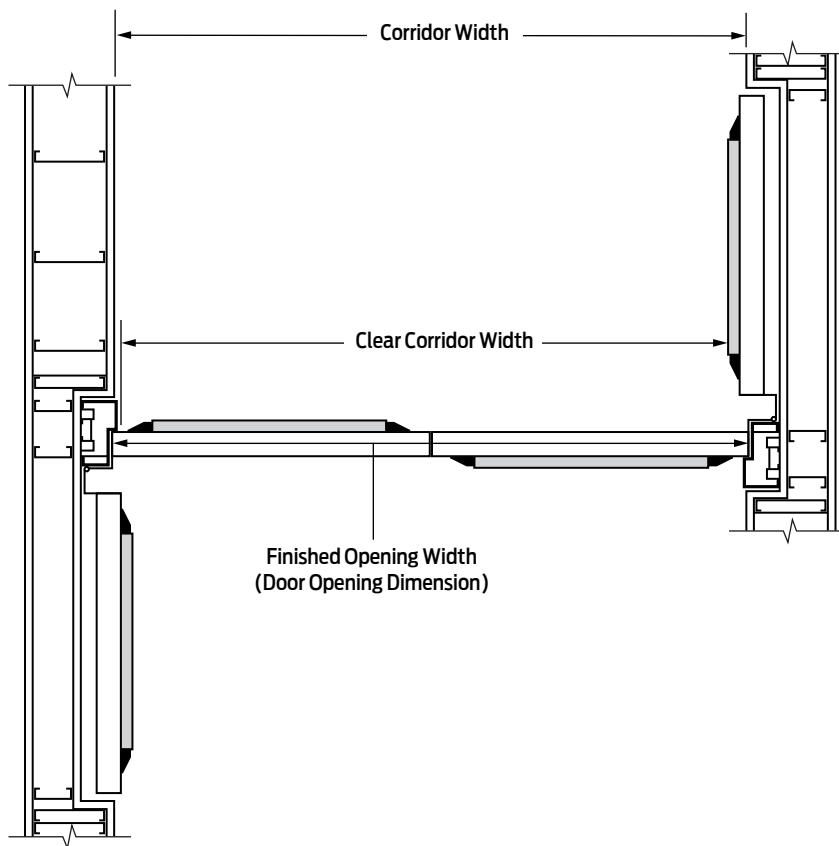

**Finished opening width (Door Opening Dimension)** is the dimension from the frame door rabbet to the opposite rabbet.

- **Note:** FE and DE Series double egress frames are 1/8" (3.2 mm) undersized from the standard nominal opening width. Example: 6'0" (1829 mm) head = 71-7/8" net width in lieu of the standard 72".

**Clear Opening Width** is the dimension between doors, measured from door face to door face, when both doors are open 90 degrees.

- **Note:** this dimension is critical for compliance with handicapped accessibility.

**Corridor Width** is the actual dimension between walls in a corridor.

- **Note:** this dimension is critical in sizing the finished opening width (Door Opening Dimension) of the double egress frame.

## Application

DE Series double egress frames are designed for use in cross corridor application where clear opening width is of major concern. Swing clear hinges or pocket pivot hinges are used. For applications where clear opening width is not critical the FE Series double egress frame is recommended.

## Purpose

DE Series double egress frames are used in cross corridor application for traffic and smoke control.

## Product availability

This product option is available for the following Steelcraft frame Series:

- DE16 and DE14 in depths from 4-3/4" (121mm) to 14" (356mm)

Standard DW, K, and MU Series double rabbeted frames

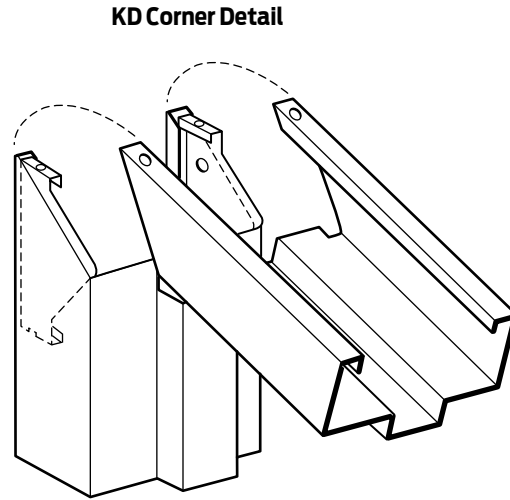
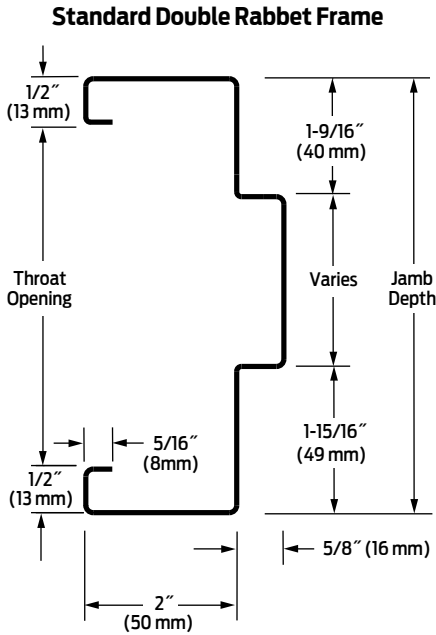

**Product:** DW, K, and MU Series

- Gauge:** 6 Ga. (1.3mm), 14 Ga. (1.7mm)
- Jamb depth:** DW and K = 4-1/2" (114mm) thru 14-3/4" (375mm) in 1/8" increments MU = 4-3/4" (114mm) thru 20" (508mm) in 1/8" increments
- Face:** Standard 2" (50mm)
- Miter:** 45° die miter with soffit tab and interlocking corner clip.

**Notes:**

- DW and K Series are installed KD.
- MU Series can be installed KD or welded.
- Equal rabbet frames are supplied when specified or in communicating frame applications (refer to page 68).
- Cased open frames are used for double acting door or applied stop applications (refer to page 73).
- Narrow double rabbet frames are used for jamb depths below 4-1/2".
- KD Corner includes wedge-lock corner clips. Screws are supplied to secure miter. Screws are supplied for all MU Series label and non-label, and for DW and K Series label only.

DW, K, and MU Series frames

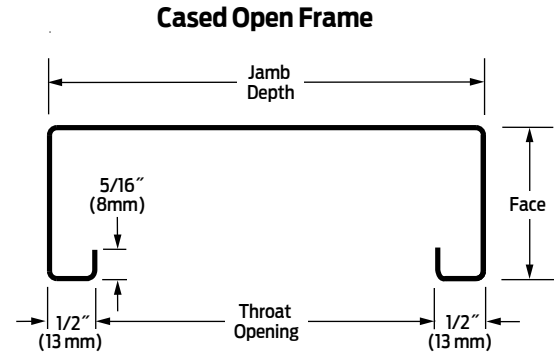
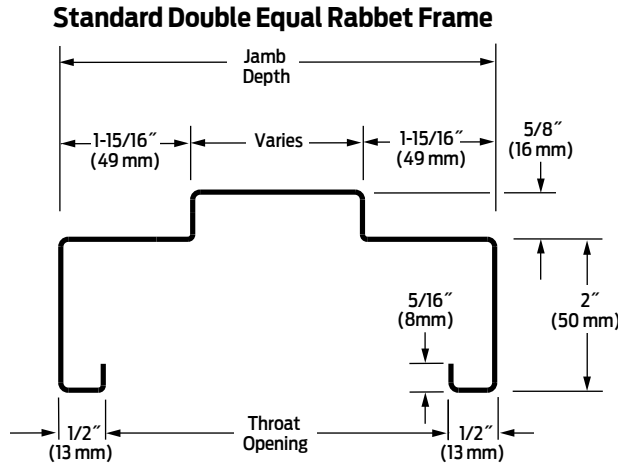

Product: DW, K, and MU Series equal rabbet frames

- Gauge:** 16 Ga. (1.3mm), 14 Ga. (1.7mm)
- Jamb depth:** 4-7/8" (124mm) min. thru 14-3/4" (375mm) in 1/8" (3.2mm) increments
- Face:** Standard 2" (50mm)
- Miter:** 45° die miter with soffit tab and interlocking corner clip.

Product: DW, K, and MU Series cased open frames

- Gauge:** 6 Ga. (1.3mm), 14 Ga. (1.7mm)
- Jamb depth:** 3-1/4" (133mm) min. thru 14-3/4" (375mm) in 1/8" (3.2mm) increments
- Face:** Standard 2" (50mm)
- Miter:** 45° die miter with soffit tab and interlocking corner clip.

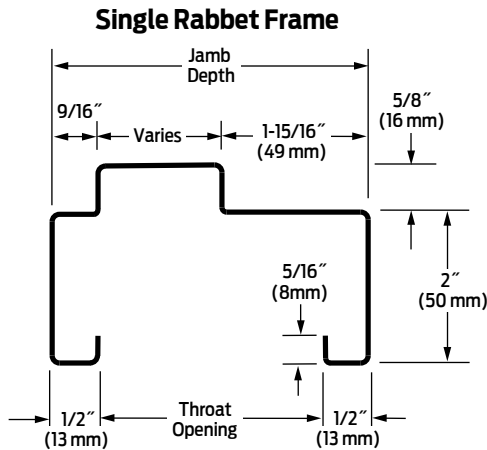

Product: DW, K, and MU Series single rabbet frames

- Gauge:** 6 Ga. (1.3mm), 14 Ga. (1.7mm)
- Jamb depth:** 3-1/4" (133mm) min. thru 4-3/8" (111mm) in 1/8" (3.2mm) increments
- Face:** Standard 2" (50mm)
- Miter:** 45° die miter with soffit tab and interlocking corner clip.

**Notes:**

1. DW and K Series are installed KD
2. MU Series can be installed KD or welded.
3. Equal rabbet frames are supplied when specified or in communicating frame applications (refer to page 68).
4. Cased open frames are used double acting door or applied stop applications (refer to page 73).
5. Single rabbet frames are used for jamb depths below 4 -1/2".

4" Head: DW, K, and MU Series frames

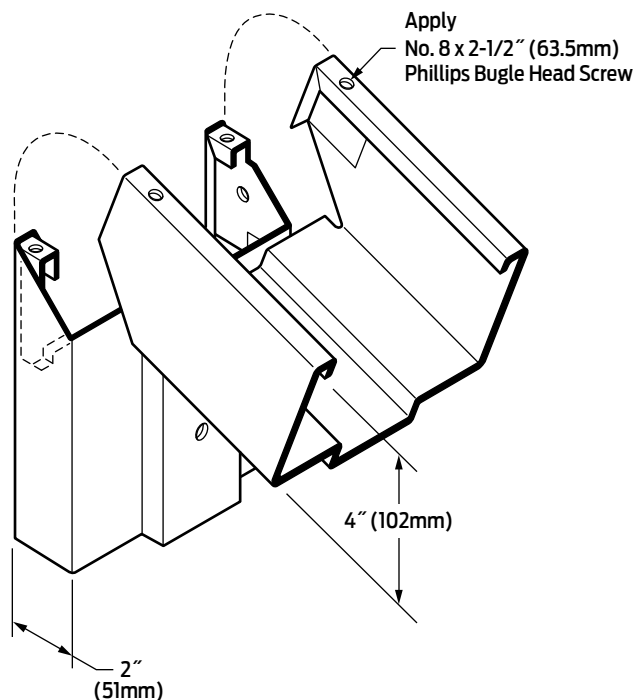
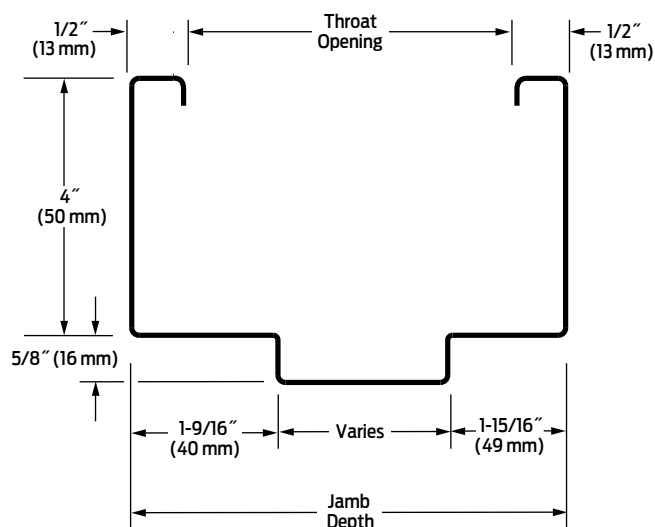

**Product:** DW16, DW14, K16, K14, MU16, and MU14

**Profile variation:** Unequal, equal or single rabet, cased open

**Jamb depth:** 3-1/4" through 14-3/4" in 1/8" increments

**Notes:**

1. MU Series frames with 4" heads are used mainly in masonry applications when 2" face heads do not match block coursing.
2. DW and K Series with 4" heads are used mainly, when installed in close proximity to a F Series or MU Series frame installed with a 4" head.
3. DW, KD, and MU corners includes wedge-lock corner clips. Screws are supplied to secure miter.

## Silencer preparations

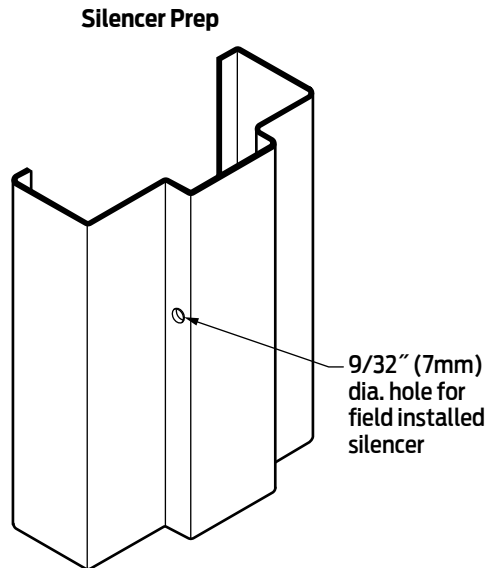

### Product

F, FN, FE, DE, MU, DW, and K Series frames both open and closed sections.

**Description:**

Frames are supplied factory prepared for field installed silencers (3 per strike jamb and/or 2 per double door head).

### Caution

When frames are to be grout filled, it is the responsibility of the installing contractor to guard off the silencer holes.

### Exceptions

Field applied self adhesive silencers are used on all mullions.

Non-labeled

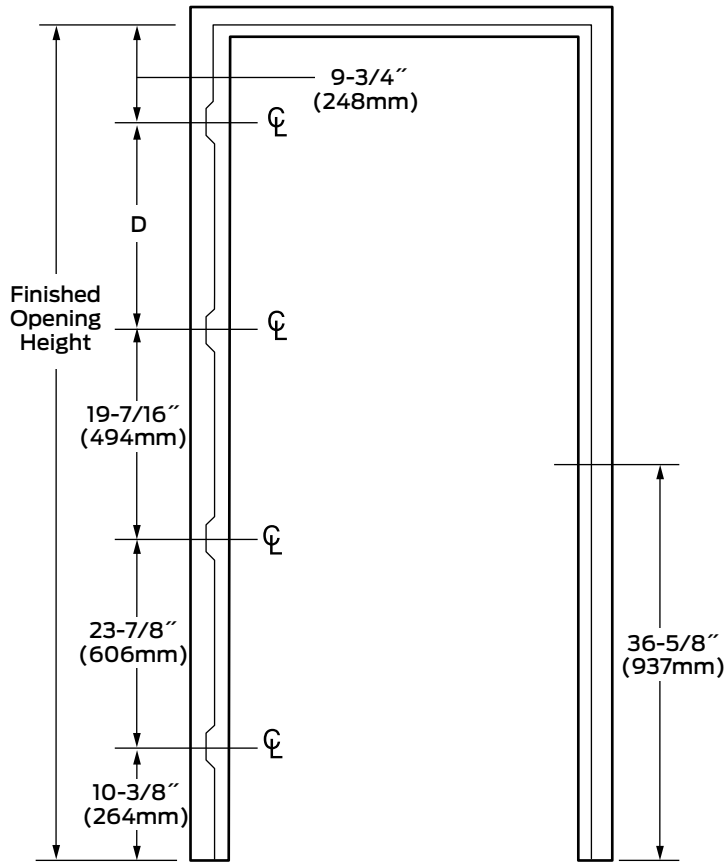

Door opening height	Dimension "D"
6'8" (2032mm)	16-9/16" (421mm)
7'0" (2134mm)	20-9/16" (522mm)
7'2" (2184mm)	22-9/16" (573mm)

Application

- Single Swing applications only: no double door configurations.
- Standard Dutch Door Frame Openings are prepared for:
  - 4-1/2" (114mm) x 4-1/2" (114mm) universal hinge reinforcements, 1 pair per leaf.
  - High Frequency Hinge Reinforcements are installed at the top hinge for each door leaf.
  - One (1) ASA 4-7/8" (124mm) high ANSI A115.1 or 2 strike aligned for top and bottom leaf.
- Optional Strike Preparations for the Top Leaf include:
  - One (1) ASA 2-3/4" (70mm) high ANSI A115.3 strike aligned for top and bottom leaf, or
  - One (1) CYL 4-7/8" (124mm) high ANSI A115.1 or 2 strike or one (1) ASA 2-3/4" (70mm).
- Sizes available from 2'0" (610mm) x 6'8" (2032mm) thru 4'0" (1219mm) x 8'0" (2438mm).

Purpose

Together with the use of a dutch door shelf, dutch doors can be viewed as an extension of nearby counter tops as well as allowing the passage of materials without opening the entire door leaf.

Product availability

This product option is available for the following Steelcraft frame Series:

- F16, F14, FN16, FN14, MU16, and MU14 in depths from 3-1/4" (83mm) to 20" (508mm).
- DW16, DW14, K16, and K14 in depths from 3-1/4" (83mm) to 14-3/4" (372mm).

Refer to pages 136-140 in the Door Section of this manual for information of applicable dutch doors.

Labeled

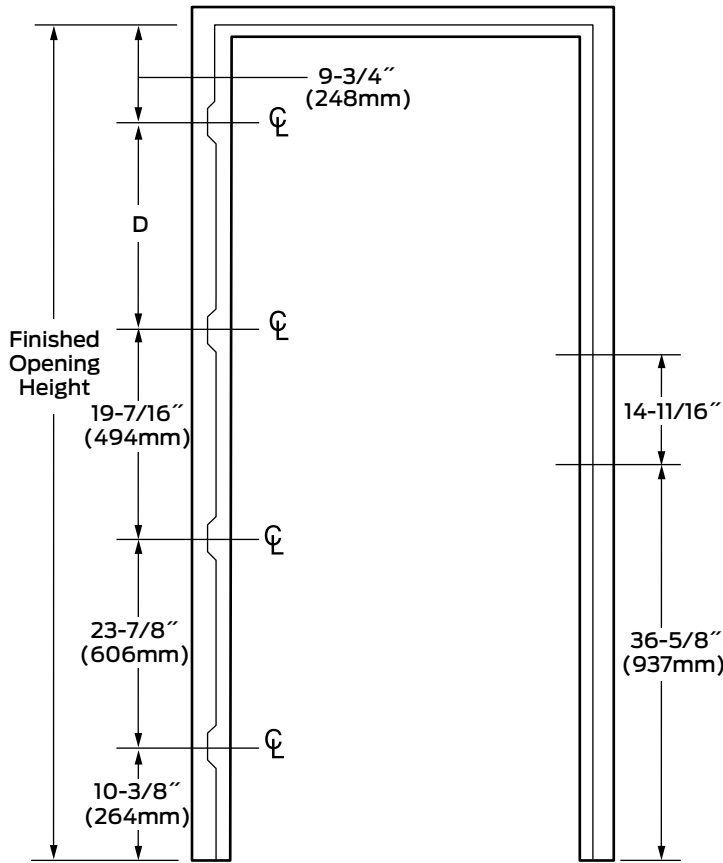

Door opening height	Dimension "D"
6'8" (2032mm)	16-9/16" (421mm)
7'0" (2134mm)	20-9/16" (522mm)
7'2" (2184mm)	22-9/16" (573mm)

Application

- Single Swing applications only: no double door configurations.
- Hinge preparations for standard dutch door frame openings include:
  - 4-1/2" (114mm) x 4-1/2" (114mm) universal hinge reinforcements, 1 pair per leaf.
  - High Frequency Hinge Reinforcements are installed at the top hinge for each door leaf.
- Optional Strike Preparations for the Top Leaf include:
  - One (1) ASA 4-7/8" (124mm) high ANSI A115.1 or 2 strike aligned for top and bottom leaf, or
  - One (1) CYL 2-3/4" (70mm) high ANSI A115.3 strike aligned for top and bottom leaf, or
  - One (1) ASA 4-7/8" (124mm) high ANSI A115.1 or 2 strike or one (1) CYL 2-3/4" (70mm) high ANSI A115.3 strike aligned for the bottom leaf due to the latch bolt from the top leaf projecting into the strike preparation in the bottom leaf (see pages 138-140).
- Frame head is equipped with a closer reinforcement.
- Sizes available from 2'0" (610mm) x 6'8" (2032mm) thru 4'0" (1219mm) x 7'2" (2184mm).

Labeled application

- Refer to pages 136-140 in the Door Section of this manual for information of applicable dutch doors.
- Maximum 3 hour approval in sizes up to 4'0" x 7'2". Refer to the Fire Rated section of this manual for fire rated approvals.

Purpose

Together with the use of a dutch door shelf, dutch doors can be viewed as an extension of nearby counter tops as well as allowing the passage of materials without opening the entire door leaf.

Product availability

This product option is available for the following Steelcraft labeled frame Series:

- F16 and F14 in depths from 3" (76mm) to 14" (356mm).
- MU16 and MU14 in depths from 3-1/4" (83mm) to 14" (356mm).

## Communicating frames

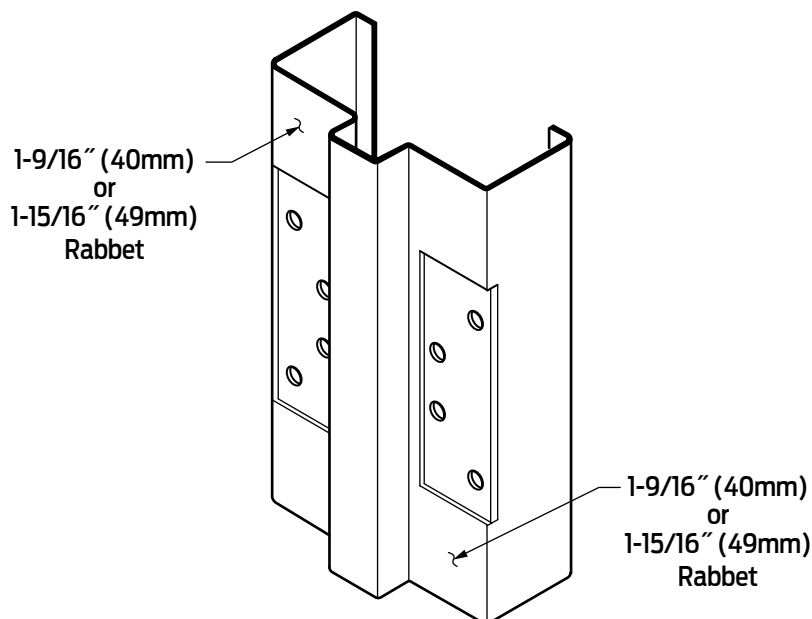

### Labeled application

Maximum 3 hour approval in sizes up to 4'0" x 8'0" single doors or 8'0" x 8'0" pairs. Refer to the Fire Rated section of this manual for fire rated approvals.

### Application

These Frames are prepared for hanging a door in each rabbet.

1. 1-15/16" (49mm) rabbets are prepared for 1-3/4" (45mm) doors.
2. The 1-9/16" (40mm) rabbets are prepared for 1-3/8" (35mm) doors.
3. 1-3/8" (35mm) x 1-3/4" (45mm) doors can be accommodated.

These communicating frames are primarily used in the Hospitality Segment of building types to separate two (2) adjoining rooms.

### Purpose

Communicating frames provide security for both adjoining rooms: each door is locked from the occupied side of each room.

### Product availability

This frame option is available for the following Steelcraft Series of Frames:

- FN16, FN14, F16, F14, MU16, and MU 14 for Singles and Pairs.
- DW16, DW14, K16, and K14 for Single Swing only.

#### Note:

1. When using DW and K Series Frames, doors are to be hinged on opposite jambs.



## Terminated or sanitary steps

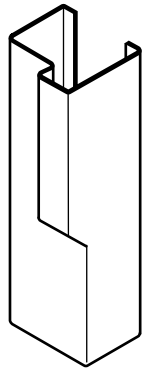

Single Rabbet

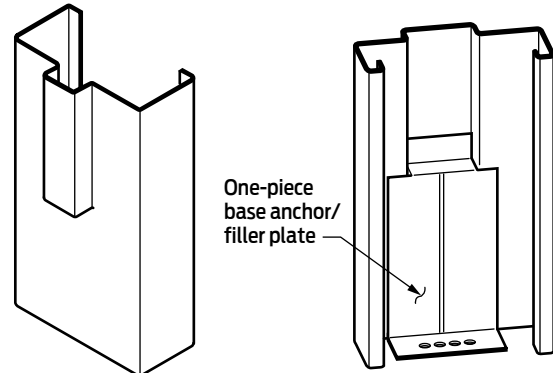

Double Rabbet

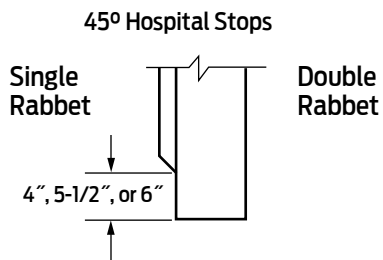

45° Hospital Stops

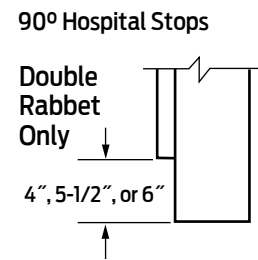

90° Hospital Stops

**Note:**

1. 45° Hospital stops are measured from the bottom of the frame to the bottom of the 45° stop miter.

**Application**

- Frames with Hospital stops are primarily used in the health care segment where cleanliness is required.
- Frames with optional hospital stop preparations include stops which do not run the full height of the frame.
- The stop terminates above the floor line and is closed with a 45° or 90° angle.

**Purpose**

The stop terminating above the floor line allows for easier cleaning and minimizes the build-up of germs, bacteria and residue at the floor level of the door opening.

**Product availability**

This frame option is available for the following Steelcraft Series Frames:

- **Single Rabbet 45°** only: F16 and F14
- **Double Rabbet 45°**: FN16, FN14, F16, F14, DW16, DW14, K16, K14, MU16, and MU14
- **Double Rabbet 90°**: FN16, FN14, F16, F14, DW16, DW14, K16, K14, MU16, and MU14
- Weld-in base anchors are included as standard and not available without.
  - F and MU Series frames come standard with weld-in one-piece base anchor/filler plates, which are not available as omit.
  - Standard base anchors for DW and K Series will remain available

**Labeled application**

- Maximum 3 hour approval in sizes up to 4'0" x 8'0" single doors or 8'0" x 8'0" pairs. Refer to the Fire Rated section of this manual for fire rated approvals
- Frames with hospital stop are available for smoke and draft applications.
- Only 4" Hospital stops with EMA anchored frames may be labeled.

## 12 Gauge full width channel

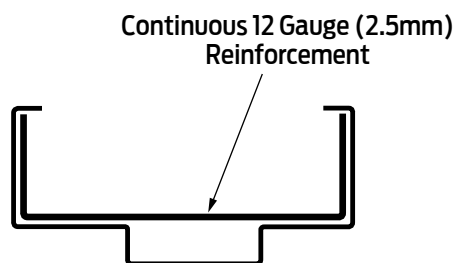
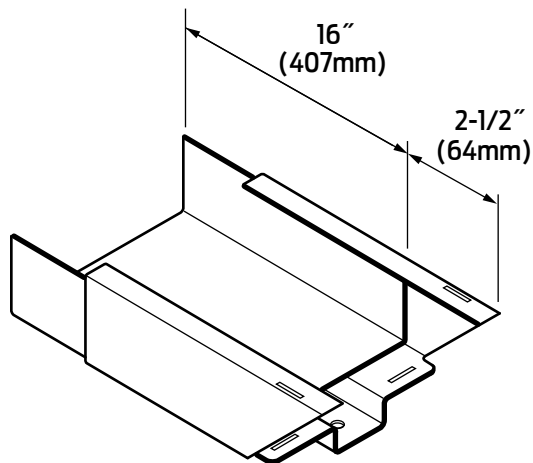

### Application

Continuous head reinforcement channels are used at the specifiers' discretion to safe guard against head sag in door opening usually over 6'0" in width. The 12 gauge continuous head reinforcement is 1" (25mm) less in length than the nominal head size, i.e., a head for a 6'0" (1829mm) pair of doors would require a 71" (1803mm) long continuous head reinforcement:

- Welded into frame head
- Minimum 2" (50mm) face dimension
- Length, other than standard, must be specified

### Purpose

When there is concern for the weight of overhead wall construction, or, when multiple surface applied hardware components are being used, this continuous steel channel has the ability to spread and transfer the load to the floor through the jambs while also providing the necessary strength and thickness for thread engagement.

#### Note:

Hollow metal frames, with or without the optional continuous head reinforcement, are not designed as or intended to be a load bearing member of wall construction.

### Product availability

This optional frame component is available for the following Steelcraft standard double rabbet profile Series frames: F16, F14, MU16, MU14, DW16, DW14, K16, and K14.

- Also available on standard FE or DE Series double egress frames

Clips (all lead lining supplied by owners)

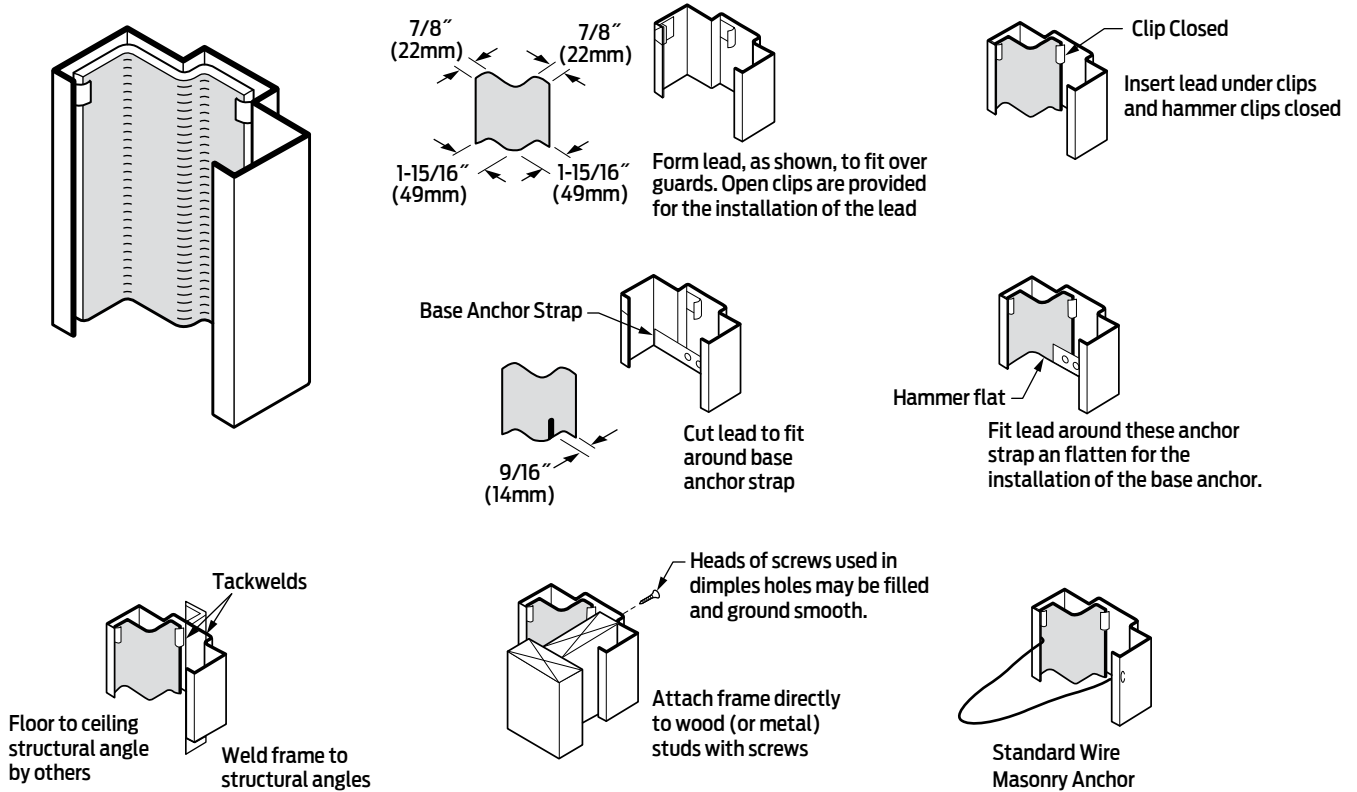

**Application**

Lead lined frames are intended for use in the X-ray Room locations in Health Care facilities.

- Frames are supplied knock-down (KD). Frame preparation and installation of lead lining by others.
- Thickness of lead varies as required or specified for the type of equipment being used.
- Lead is located on the door side of the frame, covering the inside surfaces of the face, rabbet, stop and part, or all, of the soffit. Lead linings are to be overlapped at the miters of the frame.
- It is recommended that the installation of the lead be done by a local lead contractor who may also be installing lead in the walls, floor and ceiling of the room where the lead lined frame is being used.
- For masonry wire anchoring applications only with all others being subject to the authority having jurisdiction.

**Purpose**

Attachment clips are furnished for the installation of lead lining in frames used in X-Ray rooms.

**Product availability**

This product option is available for Steelcraft labeled or non-labeled F and MU Series Frames.

**Notes:**

1. Lead supplied by others.
2. CAUTION: Any cutting of lead to fit around hardware reinforcements can cause leakage of X-Rays through the frame.
3. The doors, walls and other perimeter construction must also include integral lead lining.
4. Wire masonry anchors only (labeled and non-labeled)

## Rough buck frames

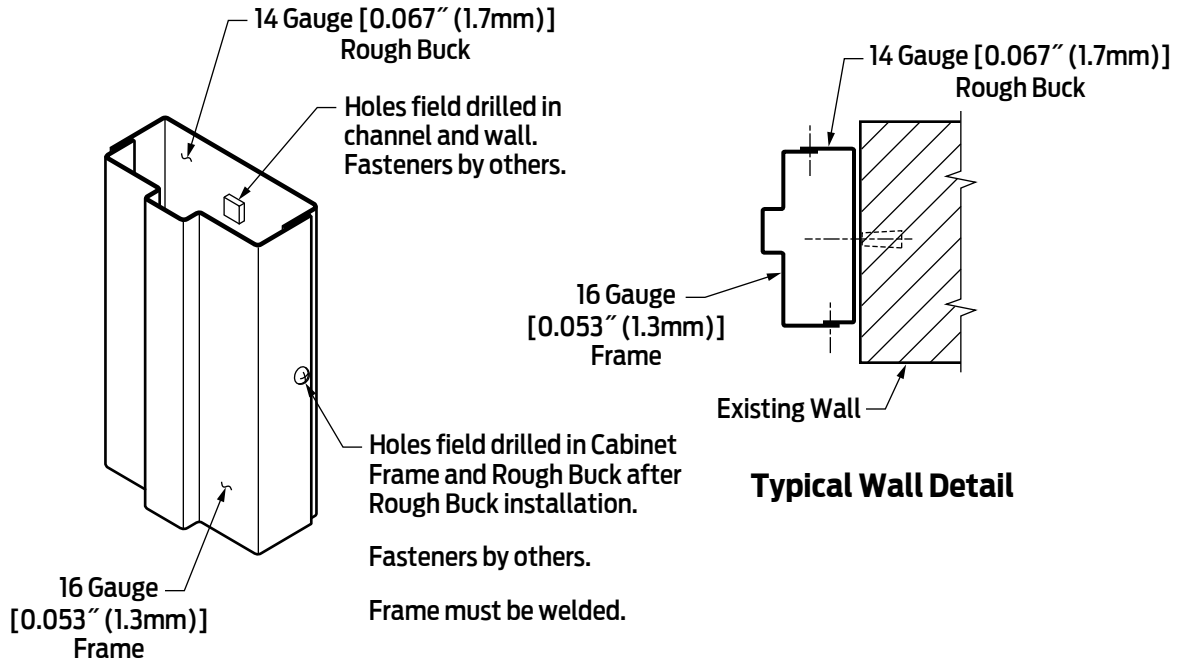

### Application

Rough Buck (Cabinet) frames are specialty frames that include a sub-channel (Rough Buck). The sub-channel is attached to an existing wall condition. The exposed steel (Cabinet Frame) is then attached to the sub-channel with fasteners provided by others.

Rough Buck (Cabinet) frames are rarely used. They are usually installed in pre-cast existing masonry wall applications.

### Purpose

Using this frame application allows contractors to install the Rough Buck relatively early in the construction cycle. The finished frame (Cabinet Frame) is then installed at a later date.

### Product availability

This frame option is available on special order only. It is a Non-Stock item. It is available as a non-labeled frame only.

## Applied stops

### Applied stops

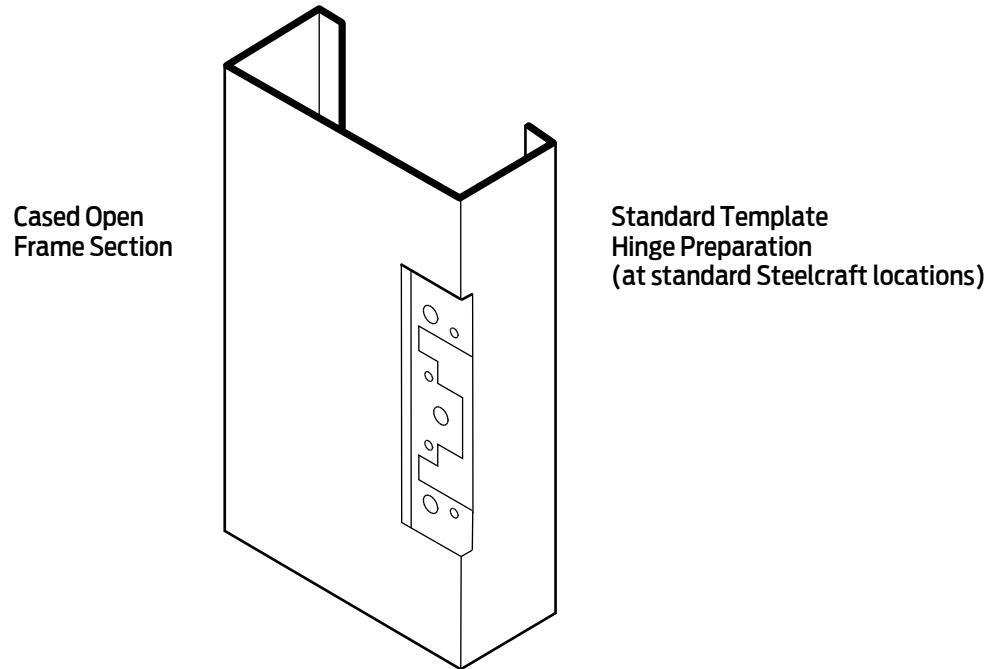

### Application

Frames with applied stops are used in commercial and/or institutional applications where sound control is a consideration. Frames configured as Cased Open sections can be prepared for standard template hinges at standard Steelcraft vertical locations. Applied stops, manufactured by others, can be attached to the center portion of the frame either as a hardware item, for safeguarding acoustical control, weatherstripping or for spring adjustable sealing. The field applied stop must provide a 1-9/16" (40mm) rabbet to accommodate a 1-3/8" (35mm) thick door, or a 1-15/16" (49mm) rabbet accommodating a 1-3/4" (45mm) thick door.

### Purpose

Frames for applied stops provide versatility for the building owner to accommodate security, sound attenuation or weather protection using integrated sealing hardware.

### Product availability

This frame option is available as non-labeled only for the following Steelcraft Series of frames: FN16, FN14, F16, F14, MU16 and MU 14, DW16, DW14, K16, and K14.

## High frequency hinge reinforcement F and FE Series

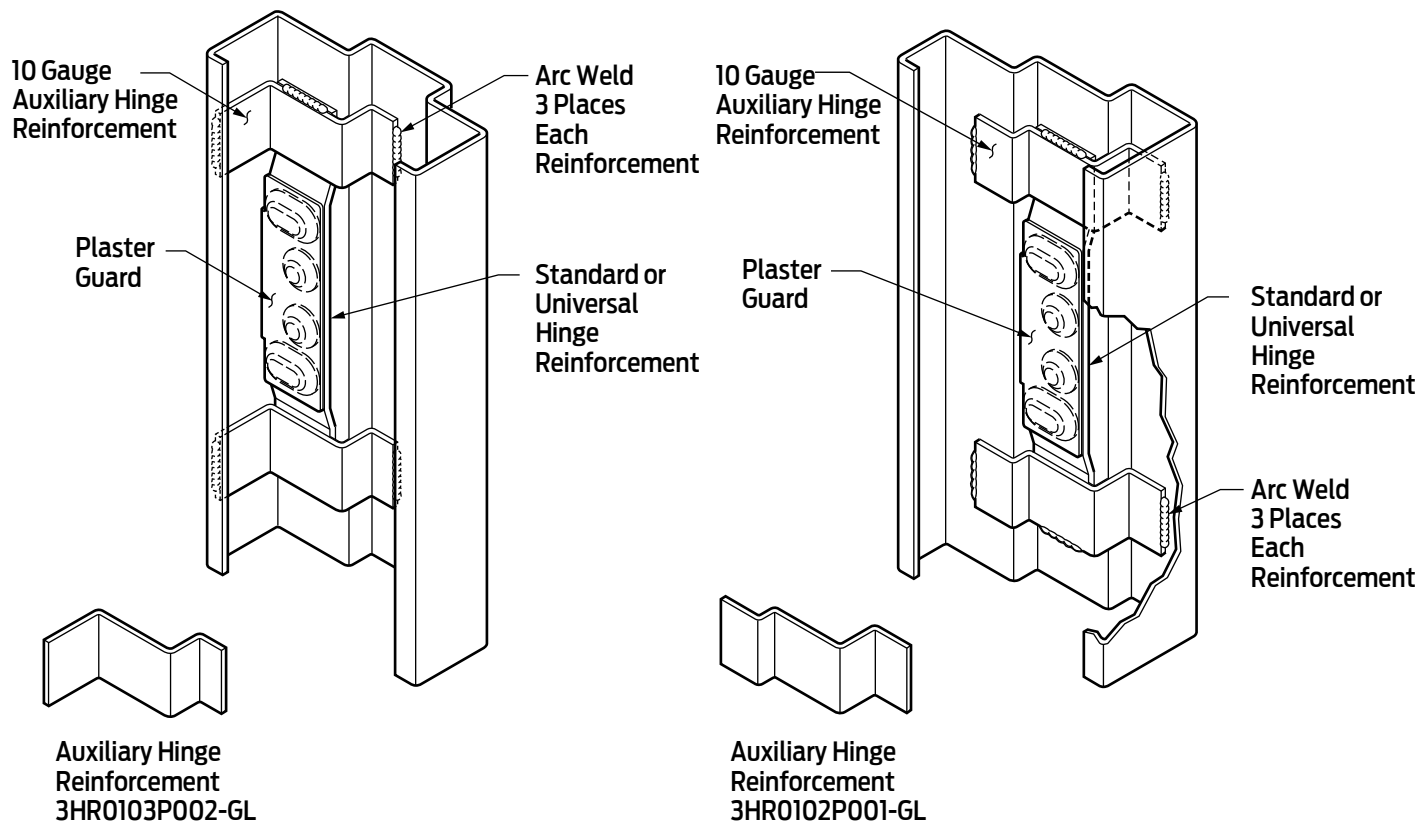

## Application

High frequency hinge reinforcements are installed in frames located in high abuse areas of commercial and/or institutional facilities formed to match the contour of the frame, the 10 gauge (3mm) auxiliary hinge reinforcement is arc welded in 3 locations of the frame:

- The frame face
- The 7 gauge (4.7mm) hinge reinforcement (projection welded to the frame at the factory)
- The soffit section The auxiliary reinforcement is primarily applicable to the top hinge reinforcement of 4-1/2" (114mm) or 5" (127mm) hinge reinforcements, but may be used on other hinge locations when specified.

## Automatic operators

- Automatic Operators, such as those from LCN <http://us.allegion.com/IRSTDocs/Catalog/109510.pdf> or any manufacturer, place a great deal of stress on the hinges of a frame and can cause failure. When using automatic operators with butt hinging systems any frame used must include all of the following:
  - High frequency hinge reinforcing installed
  - 14 gauge steel
  - 5" heavy weight hinges

## Purpose

The optional high frequency hinge reinforcement provides additional strength to the 4-1/2" (114mm) or 5" (127mm) hinge reinforcement specified for use in high abuse openings, including dutch doors, and doors with automatic operators.

## Product availability

High frequency hinge reinforcements are available factory installed, or, may be installed in the local Steelcraft distributor's fabrication shop and is applicable to all series of Steelcraft labeled and non-labeled steel frames.

## Thick doors

Over 1 3/4" thru 3" thick

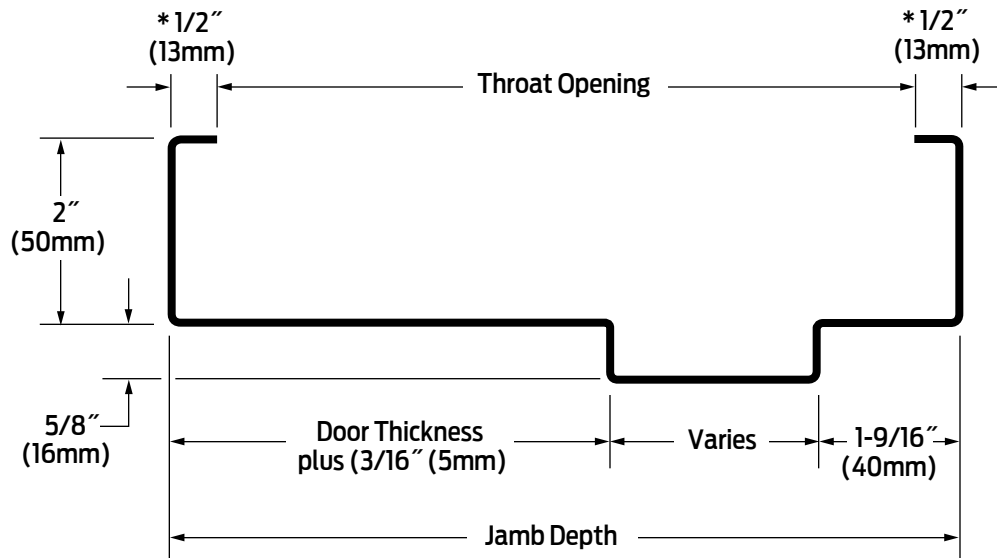
**\*Backbend:**

7/16" (11 mm) for 5-3/4" Frame depth

**Application**

- Door rabbet to be equal to the door thickness plus 3/16" (5mm) for clearances
- Backset on Hinge preparation must be specified:
  - Regular Weight
  - Heavy Weight
- Backset on Strike preparation must be specified
- Frame must be welded

**Purpose**

To accommodate the varying thickness of Specialty doors requiring a standard frame profile.

**Product availability**

This special frame option is available for Labeled and Non-labeled 16 gauge (1.3mm) and 14 gauge (1.7mm) Steelcraft F and FN Series frames.

## PS-074™ Surface applied weatherstrip

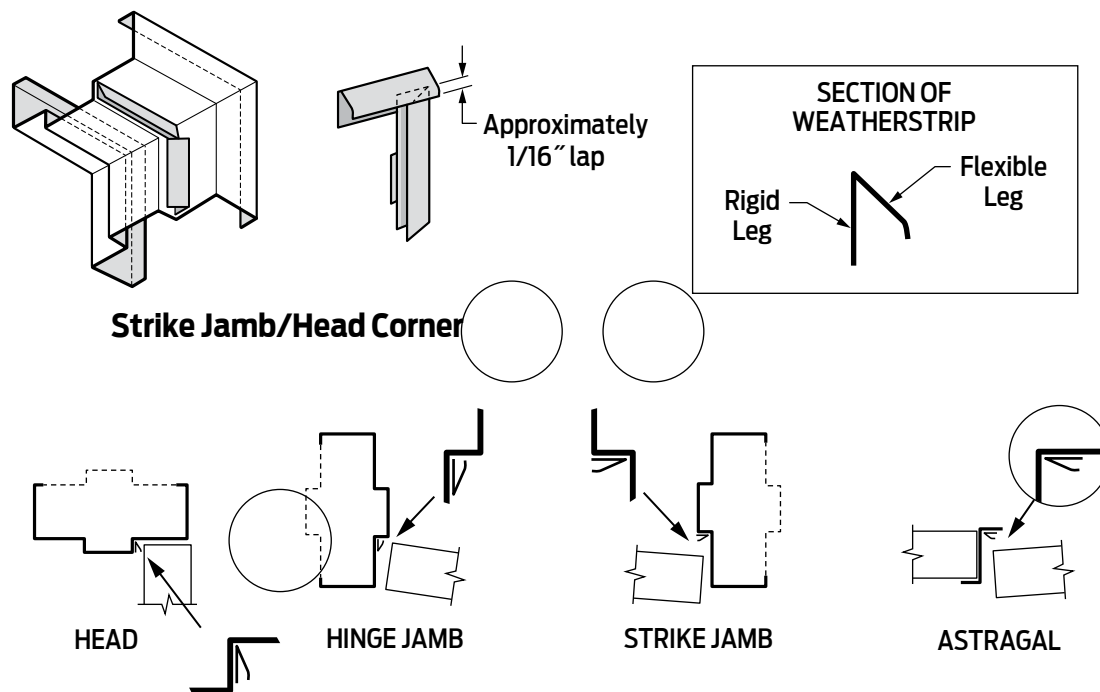

## Application

The Weatherstrip is manufactured from a flexible, black plastic material (TPE) that is resistant to paint migration, impervious to fatigue and capable of withstanding extreme temperatures:

- Ideal temperature range to apply PS-074™ Weatherstrip is 70° to 90°F (21° to 32°C).
- PS-074™ should not be applied when the temperature is below 50°F (10°C) or above 100°F (38°C).
- Warranted shelf life of adhesive is 12 months when stored at 70°F (21°C) and 50% relative humidity.
- When tested in accordance with ASTM E-283 (air infiltration) and ASTM E-331 (water resistance) PS-074™ Weatherstrip had an air infiltration rate of .074 cubic feet per minute, per lineal foot of crack, and, no water leakage.

## Purpose

Steelcraft PS074™ Weatherstrip, when applied to frames and overlapping astragals, will perform as an effective seal against adverse weather conditions.

## Product availability

This product is available from factory inventory and can be applied to the full line of Steelcraft frames. Application to label frames is subject to the *Authority Having Jurisdiction*.



## Rigid vinyl

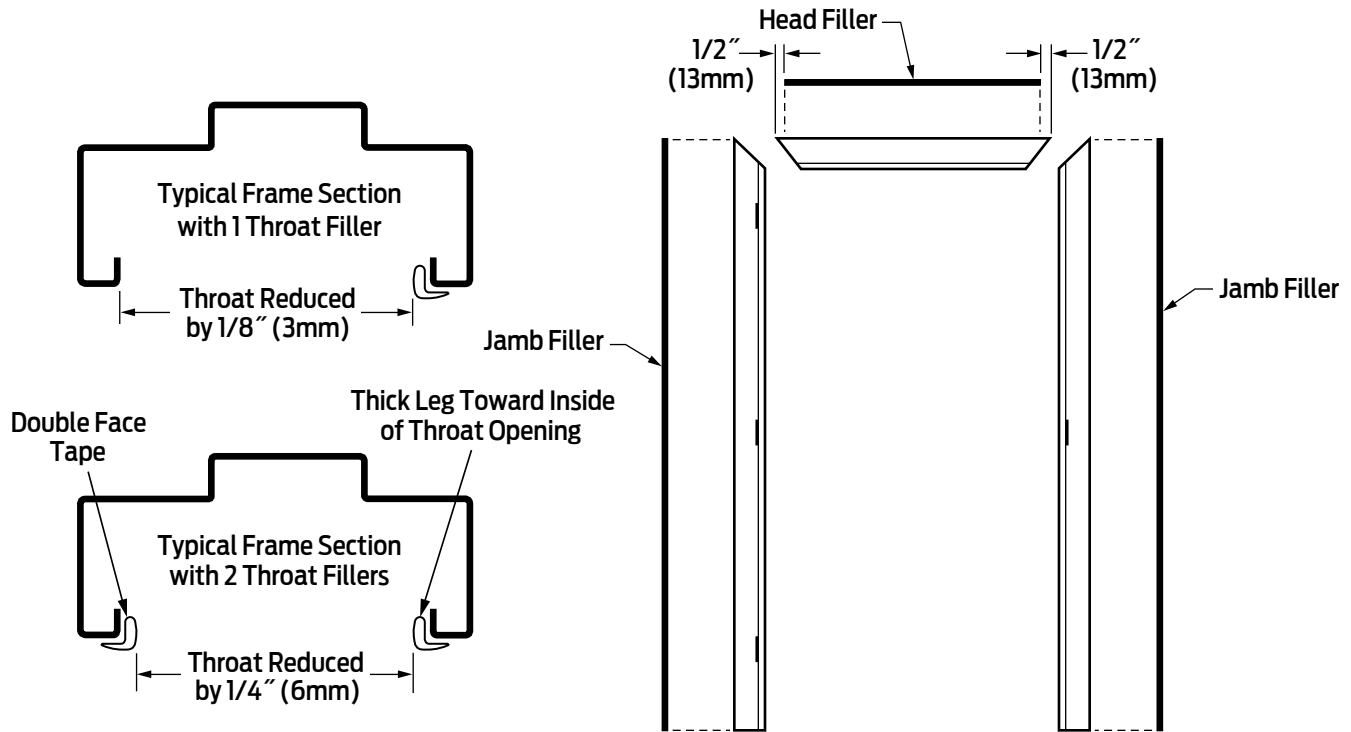

## Application

The Steelcraft Throat filler is made of extruded rigid vinyl:

- Sections supplied with double faced tape applied to the inside lip for installation on frame backbends.
- Standard length of Throat filler sections is 87" (2210mm) to ensure continuous sections that accommodate heights up to 7' 2" (2184mm).
- To be applied to the backend(s) of frames after they have been installed on the wall:
  - Jamb filler(s) are to be equal to the overall length of the jamb backend.
  - Head filler(s) are to be 1" (25mm) less than the overall length of the head backend.

## Purpose

When wall thickness is between 1/8" (3mm) to 1/4" (6mm) less than the frame throat dimension, Throat filler section(s) can be used to fill the gap, assuring the proper amount of grip required to complete the installation.

## Product availability

This optional frame component is available from factory inventory and is applicable to Steelcraft non-labeled DW and K Series frames.

## Integral

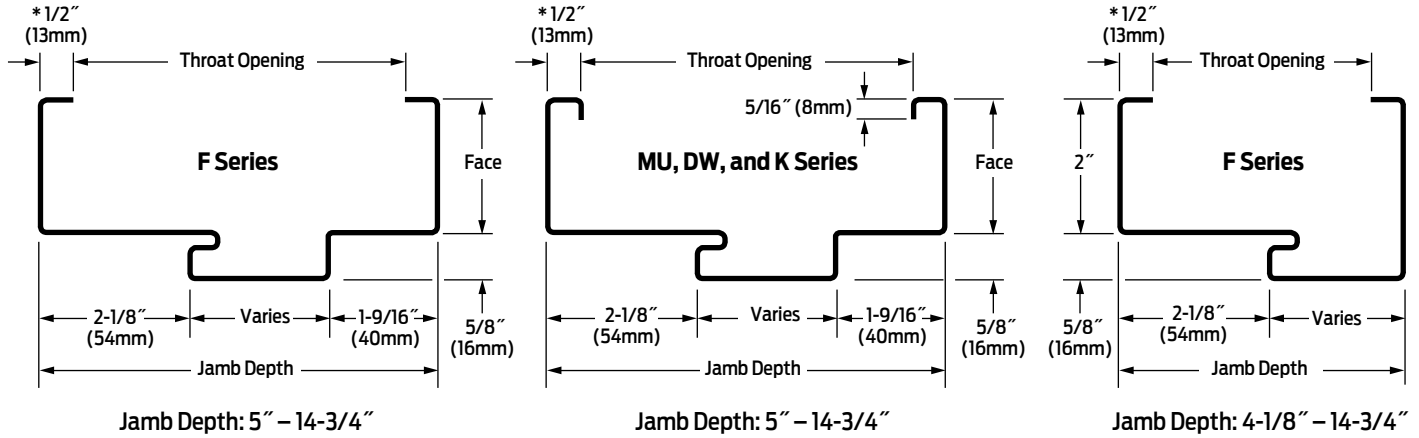

**Gauge:**

16 Ga. (1.3mm)

**Jamb Depth:**

- F, MU, DW, and K Series: 5" (127mm) min. through 14-3/4" (375mm) for standard profile.
- F Series: 4-1/8" (105mm) min. through 14-3/4" (375mm) for single rabbet
- Note: EMA anchors require minimum jamb depth of 5-5/8" for standard profile frames.

**Face:**

Standard 2" (51mm) face head and jamb dimensions with 4" (102mm) face head optional on equal and unequal rabbet only.

**Miter:**

45° die miter with soffit tab and interlocking corner clip.

**Opening Size:**

8'0" x 8'0" (2439mm x 2439mm) maximum.

**Profile Options:**

1-15/16" (49mm) or 1-9/16" (40mm) equal rabbet profiles or single rabbet profiles.

**\*Backbend:**

7/16" (11mm) for 5-3/4" frame jamb depth on F Series only.

## Application

The Integral Kerf frame is intended for use in areas, interior or exterior, which require a further reduction in air flow from the door and frame. The kerf material is manufactured from a durable, UV-resistant, polyethylene cladding covering the urethane foam. The gasket material complies with UL 10C. They have also passed the water penetration test up to 34 mph per ASTM E-331.

- Frames are supplied knock-down as standard with gasket material shipped loose for insertion into frame by others.
- Replacement gasket material can be found in the Parts section of the price manual.

## Product availability

This optional frame feature is available for the following Steelcraft frame series:

- Equal and unequal rabbet F16, MU16, DW16 and K16
- Single rabbet F16

## Labeled application

Maximum 3 hour fire rating approval up to an 8'0" x 8'0" opening size.

**Flush Frames ..... 81**  
 F, FN, MU, FE, and DE Series ..... 81

**Drywall Frames ..... 83**  
 DW and K Series ..... 83

**Anchor Details..... 85**  
 Wire masonry ..... 85  
 Masonry T ..... 85  
 Yoke & strap masonry ..... 86  
 Butterfly existing wall..... 87  
 Hat spacer existing wall ..... 88  
 Tube & strap existing wall..... 88  
 Universal stud..... 89  
 Wood stud ..... 89  
 Wood stud ..... 90  
 Closed steel stud ..... 90  
 Flush steel stud ..... 91  
 Recessed steel stud..... 91  
 Field adjustable base ..... 92  
 Fixed base ..... 92  
 Compression jamb ..... 93  
 Security (optional) for DW and K Series ..... 93  
 Adjustable for DW Series ..... 94  
 Base for K Series..... 94  
 Mullion base..... 95  
 Sill section base ..... 95  
 Corner post base..... 96

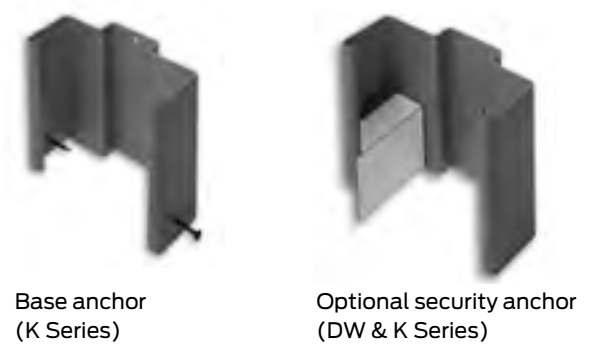
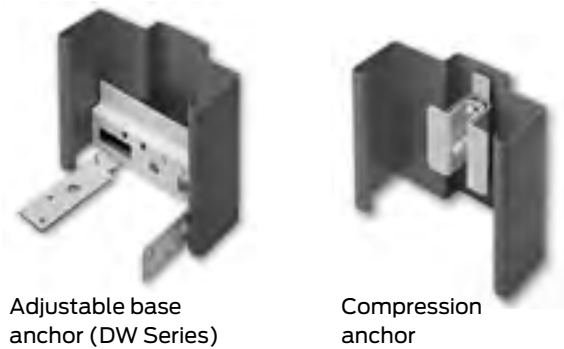
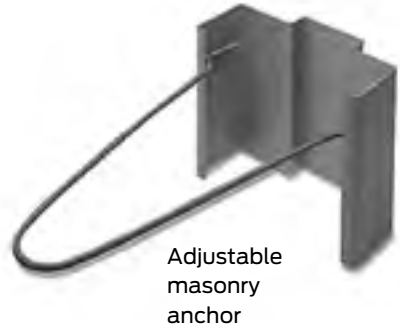
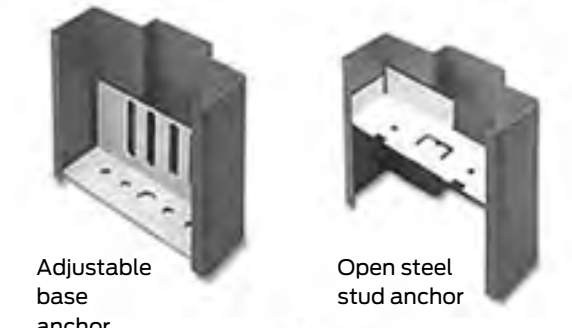
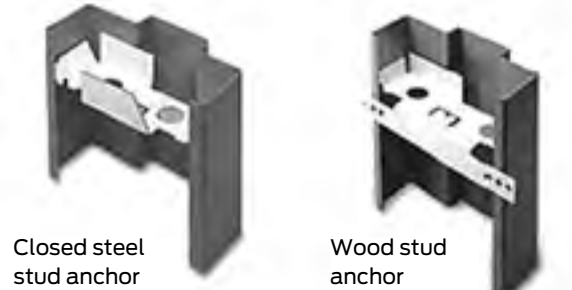

This page intentionally left blank

## Flush frames

## F, FN, MU, FE, and DE Series

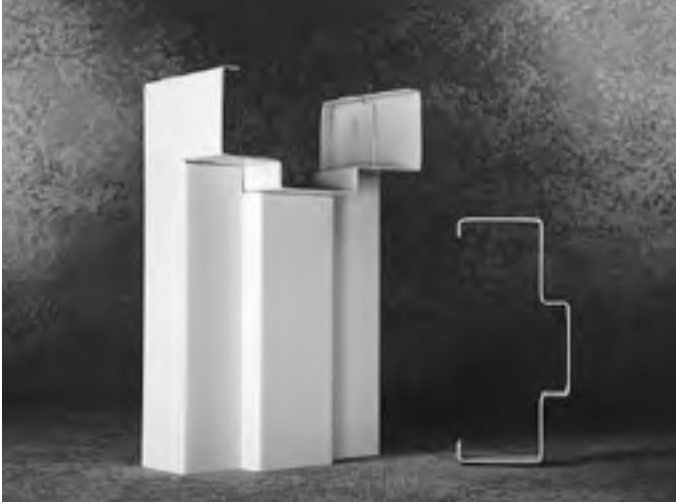

## Anchoring and installation notes

1. **All Frames** in this category are supplied standard with masonry wire or lock-in jamb anchors and adjustable base anchors. Anchors are designed for maximum wall/frame engagement and installation flexibility.
2. **Anchoring Applications:**
  - **Masonry Wall:** Masonry wire anchors (3/16" [5mm] diameter) provide maximum engagements in mortar joints, and allow for full internal grouting during installation. The anchor is to be spread wider than the jamb depth and twisted into position. Adjustable base anchors are attached directly to the floor and adjusted. The wall is built around the anchored frame.
  - **Existing Masonry Walls:** Specifically designed (18 Ga.) jamb anchors are used to add support for bolting the frame into the rough opening of an existing wall.
  - **Wood Stud Walls:** Lock-in (18 Ga.) jamb anchors are designed to be attached to the wood studs of a rough opening.
  - **Steel Stud Walls:** Lock-in (18 Ga.) jamb anchors are designed to be attached to the webbing of the closed steel studs which are built around the frame.
  - **Universal Stud Wall Anchors:** Universal lock-in (18 Ga.) jamb anchors are designed for use in either wood or steel stud wall applications. Maximum jamb depth is 9-1/2".
3. **Adjustable Base Anchors:**
  - Field attached (16 Ga.) base anchors provides direct attachment and adjustability for out of level base surface conditions.
  - If frame is NOT to be set directly on the floor (slab) adjust base anchor UPWARD as required.
4. **Special Frame Anchors:** Anchor details and availability of lock-in anchors will vary with the following frame profile changes:
  - Single Rabbet: all details will vary.
  - Double Rabbet: weld-in anchors required over 9-1/2" jamb depth.
  - FE and DE Series Double Egress Frames: Anchor details will vary due to frame and application conditions.
5. **Installation** shall conform to the published Steelcraft installation instructions, ANSI A250.11 *Recommended Erection Instructions for Steel Frames*, and HMMA 84.
6. **Installation Caution Notice: Grouted Frames:**
  - When temperature conditions necessitate an additive to be used in the plaster or mortar to prevent freezing, the contractor installing the frames must coat the inside of the frames in the field with a corrosion resistant coating per ANSI A250.11 *Recommended Erection Instructions for Steel Frames*.
  - When frames are to be grouted full, silencers must be field installed prior to grouting.
  - Steel frames, including fire rated frames, do not require grouting. Grouting is not recommended for frames in drywall.
7. **All Fire Rated frames** must be installed in accordance with NFPA Pamphlet 80 and the *Authority Having Jurisdiction*.

**F, FN, MU, FE, and DE Series**

Standard Lock-In Jamb Anchors are supplied on standard F Series frames having 2" faces

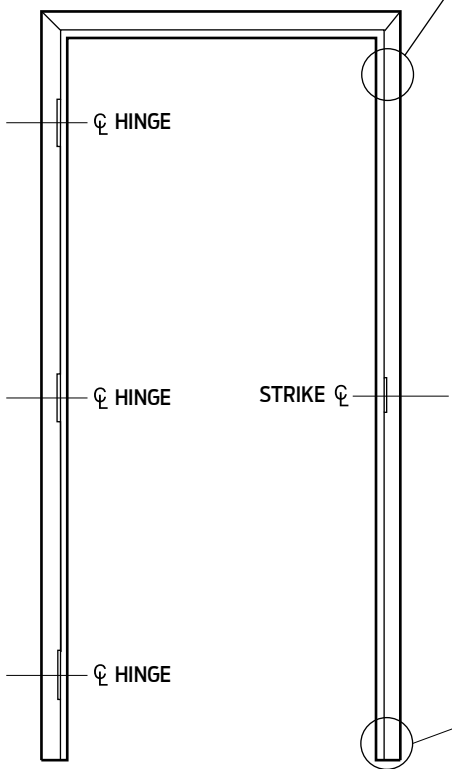

**Masonry Wall Applications**

**Wire Masonry Anchor**

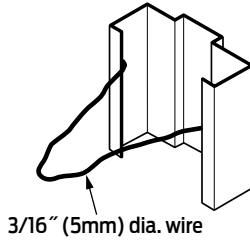

**Masonry "T" Anchor**

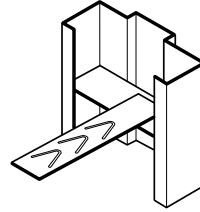

**Existing Wall Anchor**

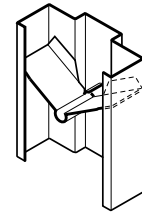

**Stud Wall Applications**

**Universal Stud Anchor**

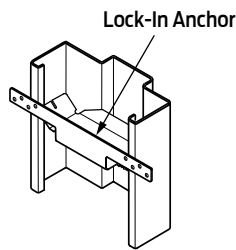

**Anchor for Steel Stud Partition**

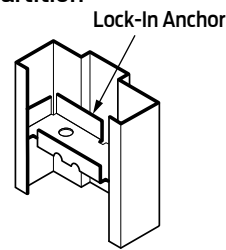

**Anchor for Wood Stud Partition**

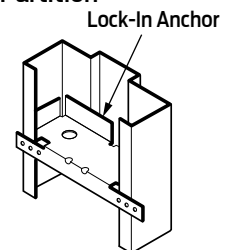

Adjustable Sill Anchors are provided as standard

Attached with S.M. screws furnished

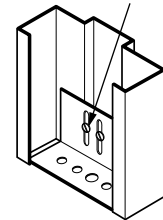

Maximum adjustment  
1-3/8" (35mm)  
below bottom of frame

**Anchor Quantities:**

- 3 per jamb through 7'6" height
- 4 per jamb over 7'6" to 12'0" height
- 1 adjustable base anchor per jamb

**Anchor Locations:**

- Locate all anchors on hinge jamb as close to top of hinge reinforcement as possible.
- Locate anchors on strike jamb in the corresponding position as the hinge jamb.

Specialty Weld-In Jamb Anchors are supplied for custom frames and special wall applications when specified.

**Masonry Wall Application**

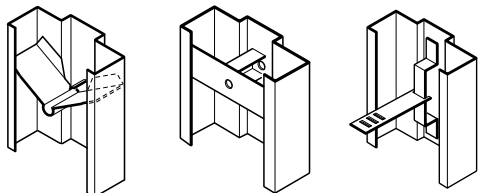

Existing Wall Anchor    Weld-In Tube & Strap Anchor for Special Profile Frames    Weld-In Yoke Strap & Masonry Anchor

**Stud Wall Anchors**

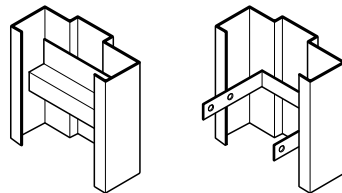

"Z" Steel Stud Weld-In Anchor for Special Profile Frames    Weld-In Wood Stud Anchor

**Sill Anchors**

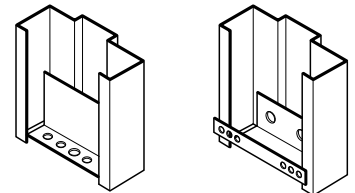

Weld-In Floor Anchor    Weld-In Wood Stud Base Anchor

# Drywall frames

## DW and K Series

### Anchoring and installation notes

1. **Drywall Frames** are supplied standard with field adjustable compression anchors in each jamb and adjustable base anchors. DW Series Frames are designed especially for use in installations using wall baseboards.
2. **Anchoring Applications:**
  - **Masonry Wall:** Not recommended.
  - **Wood and Steel Stud Walls:** Adjustable compression anchors are factory located near the top of each jamb. These anchors can be easily adjusted with either a screw driver or power driver. Adjustable lock-in base anchors are provided for attachment directly to the wall floor (sill) runner.
  - **Optional Security Anchor:** Security Stud Anchors are recommended in frames over 8' 0" (2438mm) high or in frames installed in areas where security is a priority. Locate the Security Stud Anchor immediately above or below the strike reinforcements, and on both faces (secure and entrance sides) of the jamb. Security Stud Anchors may be used in both the strike and hinge jambs. They are also recommended to be used in the head of frames for pairs of doors.
3. **Grouting of the DW and K Series Frames** is not recommended.
4. **Installation** shall conform to the published Steelcraft installation instructions, ANSI A250.11 *Recommended Erection Instructions for Steel Frames*, and HMMA 840.
5. Installation Caution Notice:
  - After the frame pieces have been installed over the wallboard, the frame is squared by adjusting the compression anchor screws located in the soffit of the jambs. Turning the screw in a clockwise direction will tighten the frame.
  - DO NOT over tighten the compression anchors.
  - Check to insure the opening is plumb.
6. All Fire Rated frames must be installed in accordance with NFPA Pamphlet 80 and the *Authority Having Jurisdiction*.



DW and K Series

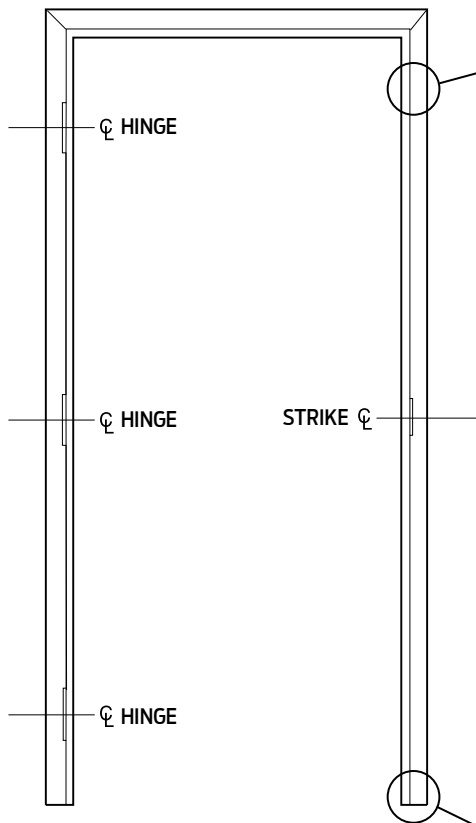

Standard Field Adjustable Compression Jamb Anchors are supplied as standard for DW & K Series frames having 2" faces

Stud Wall Applications (refer to page 93)

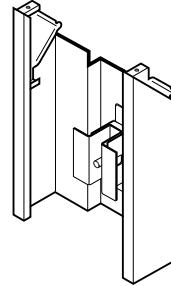

Jamb/Compression Anchor (refer to page 93)

Optional Security Applications (refer to page 93)

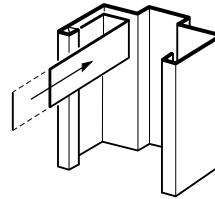

**Anchor Quantities:**

- 1 compression anchor per jamb through 9" depth
- 2 compression anchors per jamb for 9" depth and greater
- 2 twist-in strap base anchors per jamb

**Anchor Locations:**

- Compression anchors are factory installed near the top of each jamb.
- The twist-in anchors are installed into the Base Anchor Attaching Strap that is factory installed at the bottom of each jamb.

**Anchor Options:**

- Security Jamb Anchor
  - See description on the previous page
  - See details on Page 93

Either Adjustable Sill Anchors or Counter Sunk Sill Anchor Holes are provided as standard

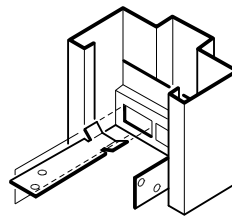

DW Series Adjustable Lock-in Base Anchor (refer to page 94)

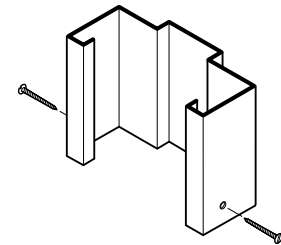

K Series Base Anchor (refer to page 94)



## Anchor details

## Wire masonry

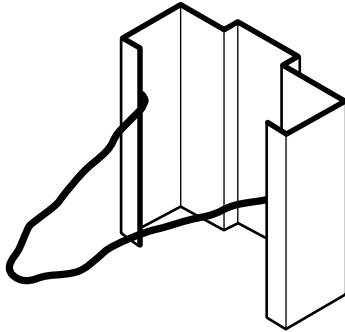

1. **Material:** 3/16" (5mm) dia. wire
2. **Supplied:** Shipped loose for field installation
3. **Applicable Frame Series:** F, FN, MU, FE, and DE
4. **Profile variations:** SR: Single Rabbet  
DR: Double Rabbet (equal & unequal)  
CO: Cased Open NOTE: profile must have back bends
5. **Frame depths:** 3" through 14-3/4"
6. **Face variations:** Fits all face variations
7. **Frame attachment:** Lock-in
8. **Application:** Ship loose to jobsite, field installed
9. **Wall construction:** Masonry block or brick
10. **Fire label applications:** UL/WH 3 hour max.
11. **Base anchor:** See page 92 for base anchor details

## Masonry T

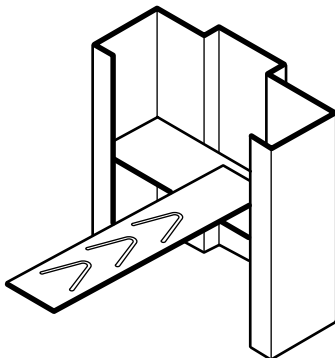

1. **Material:** 18 Ga. Galvannealed Steel
2. **Supplied:** Shipped loose for field installation
3. **Applicable Frame Series:** F, FN, MU, FE, DE
4. **Profile variations:** SR: Single Rabbet  
DR: Double Rabbet (equal & unequal)  
CO: Cased Open  
NOTE: profile must have backbends
5. **Frame depths:** All frame depths Ordered specifically to fit frame depths
6. **Face variations:** Fits all face variations
7. **Frame attachment:** Lock-in
8. **Application:** Ship loose to jobsite, field installed
9. **Wall construction:** Masonry block or brick
10. **Fire label applications:** UL/WH 3 hour max.
11. **Base anchor:** See page 92 for base anchor details

## Yoke &amp; strap masonry

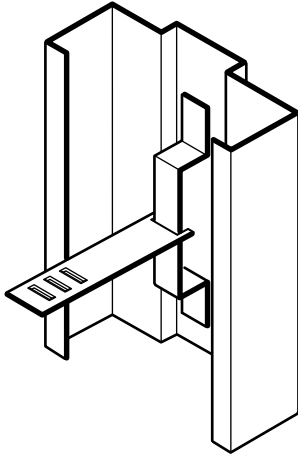

- |                                                        |                                                                                               |
|--------------------------------------------------------|-----------------------------------------------------------------------------------------------|
| 1. <b>Material:</b>                                    | 18 Ga. Galvannealed Steel                                                                     |
| 2. <b>Supplied:</b><br>shipment                        | Factory welded in prior to                                                                    |
| 3. <b>Applicable Frame Series:</b>                     | F, FN, MU, FE, DE                                                                             |
| 4. <b>Profile variations:</b>                          | SR: Single Rabbet<br>DR: Double Rabbet<br>(equal & unequal)<br>CO: Cased Open                 |
| 5. <b>Frame depths:</b>                                | All frame depths For frame depths<br>over 12-3/4" 2 anchors welded at<br>each anchor location |
| 6. <b>Face variations:</b><br>specifically to fit face | Fits all face variations Ordered                                                              |
| 7. <b>Frame attachment:</b>                            | Arrives to jobsite welded<br>into frame                                                       |
| 8. <b>Application:</b>                                 | Factory welded                                                                                |
| 9. <b>Wall construction:</b>                           | Masonry block or brick                                                                        |
| 10. <b>Fire label applications:</b>                    | UL/WH 3 hour max.                                                                             |
| 11. <b>Base anchor:</b>                                | See page 92 for base anchor<br>details                                                        |

## Butterfly existing wall

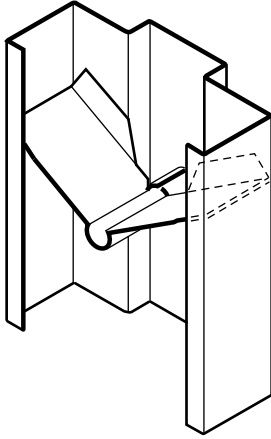

1. **Material:** 18 Ga. Galvannealed Steel
2. **Supplied:** Shipped loose for field installation
3. **Applicable Frame Series:** F
4. **Profile variations:** SR: Single Rabbet  
DR: Double Rabbet (equal & unequal)  
CO: Cased Open  
NOTE: profile must have a backbend
5. **Frame depths:** 4-3/4" through 9-1/8" Adjustable  
Fits all depths up to 9-1/8"  
Single Rabbet up to 3-3/4"
6. **Face variations:** 2" face only.
7. **Frame attachment:** Lock-in or factory welded
8. **Application:** Ship loose to jobsite, field installed. When specified welded, arrives to jobsite welded into frame.
9. **Wall construction:** Masonry block, brick, existing or pre-cast
10. **Fire label applications:** UL/WH 3 hour max.
11. **Base anchor:** Additional butterfly anchor used as the base anchor

## Hat spacer existing wall

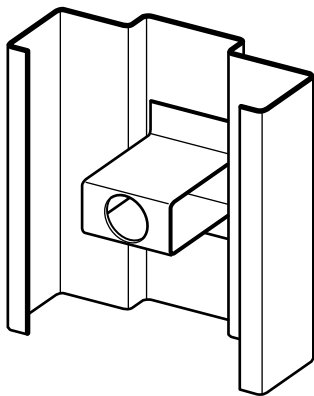

1. **Material:** 16 Ga. Galvannealed Steel
2. **Supplied:** Welded in prior to shipment
3. **Applicable Frame Series:** F, FN, MU, FE, DE
4. **Profile variations:** SR: Single Rabbet  
DR: Double Rabbet (equal & unequal)  
CO: Cased Open  
NOTE: profile must have a backbend
5. **Frame depths:** All frame depths  
For frame depths over 9-1/4" 2 anchors welded at each anchor location
6. **Face variations:** Fits all face variations
7. **Frame attachment:** Factory welded
8. **Application:** Arrives at jobsite welded into frame
9. **Wall construction:** Masonry block, brick, existing or pre-cast
10. **Fire label applications:** UL/WH 3 hour max.
11. **Base anchor:** Additional Hat Spacer anchor used as the base anchor

## Tube & strap existing wall

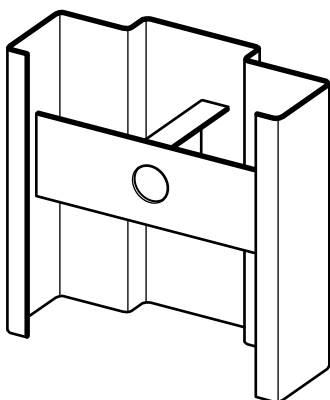

1. **Material:** 16 Ga. Galvannealed Steel
2. **Supplied:** Welded in prior to shipment
3. **Applicable Frame Series:** F, FN, MU, FE, DE
4. **Profile variations:** SR: Single Rabbet  
DR: Double Rabbet (equal & unequal)  
CO: Cased Open  
NOTE: profile must have a backbend
5. **Frame depths:** All frame depths  
For frame depths over 9-1/4" 2 anchors welded at each anchor location
6. **Face variations:** Fits all face variations
7. **Frame attachment:** Factory welded
8. **Application:** Arrives at jobsite welded into frame
9. **Wall construction:** Masonry block, brick, existing or pre-cast
10. **Fire label applications:** UL/WH 3 hour max.
11. **Base anchor:** Additional Tube & Strap anchor used as the base anchor

## Universal stud

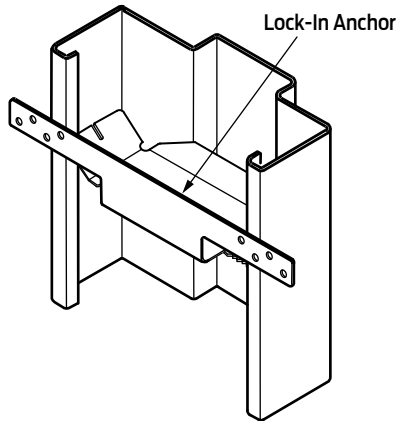

1. **Material:** 18 Ga. Galvannealed Steel
2. **Supplied:** Shipped loose for field installation
3. **Applicable Frame Series:** F, MU
4. **Profile variations:** DR: Double Rabbet (equal & unequal)  
CO: Cased Open  
NOTE: profile must have a backbend
5. **Frame depths:** 4-3/4", through 9-1/2" Ordered specifically to fit frame depths
6. **Face variations:** 2" only
7. **Frame attachment:** Lock-in
8. **Application:** Ship loose to jobsite, field installed
9. **Wall construction:** Wood stud or steel stud walls
10. **Fire label applications:** UL/WH 3 hour max.
11. **Base anchor:** Additional wood stud anchor used as the base anchor

## Wood stud

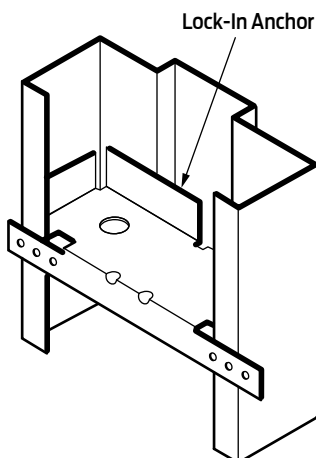

1. **Material:** 18 Ga. Galvannealed Steel
2. **Supplied:** Shipped loose for field installation
3. **Applicable Frame Series:** F
4. **Profile variations:** DR: Double Rabbet (equal & unequal)  
CO: Cased Open  
NOTE: profile must have a backbend
5. **Frame depths:** 4-3/4", 5-3/4", 6-3/4", 7-3/4", 8-3/4" -non-adjustable
6. **Face variations:** 2" only
7. **Frame attachment:** Lock-in
8. **Application:** Ship loose to jobsite, field installed
9. **Wall construction:** Wood stud walls
10. **Fire label applications:** UL/WH 3 hour max.
11. **Base anchor:** Additional wood stud anchor used as the base anchor

## Wood stud

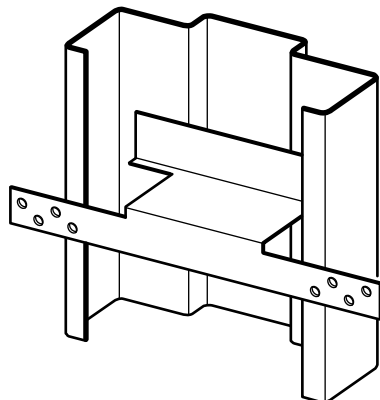

1. **Material:** 16 Ga. Galvannealed Steel
2. **Supplied:** Welded in prior to shipment
3. **Applicable Frame Series:** F, FN, MU, FE, DE
4. **Profile variations:** DR: Double Rabbet (equal & unequal)  
CO: Cased Open  
NOTE: profile must have a return
5. **Frame depths:** All frame depths
6. **Face variations:** Fits all face variations  
Ordered specifically to fit face
7. **Frame attachment:** Must be welded to frame
8. **Application:** Arrives at jobsite welded into frame
9. **Wall construction:** Wood stud walls
10. **Fire label applications:** UL/WH 3 hour max.
11. **Base anchor:** Additional wood stud anchor used as the base anchor

## Closed steel stud

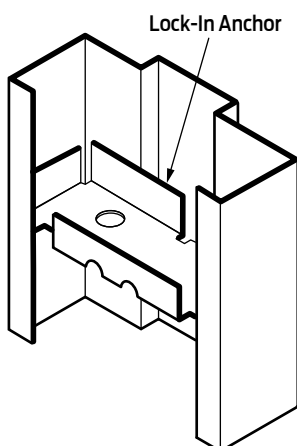

1. **Material:** 18 Ga. Galvannealed Steel
2. **Supplied:** Shipped loose for field installation
3. **Applicable Frame Series:** F
4. **Profile variations:** DR: Double Rabbet (equal & unequal)  
CO: Cased Open  
NOTE: profile must have a return
5. **Frame depths:** 4-3/4", 5-3/4", 6-3/4", 7-3/4", 8-3/4"-non-adjustable
6. **Face variations:** 2" only
7. **Frame attachment:** Lock-in
8. **Application:** Ship loose to jobsite, field installed
9. **Wall construction:** Closed steel stud walls
10. **Fire label applications:** UL/WH 3 hour max.
11. **Base anchor:** See page 92 for base anchor details

## Anchor details

## Flush steel stud

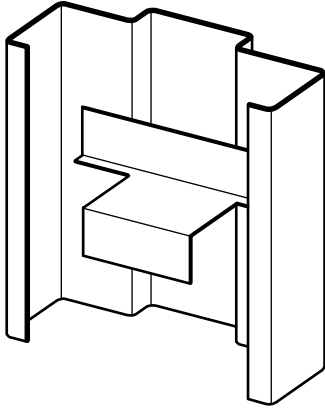

1. **Material:** 16 Ga. Galvannealed Steel
2. **Supplied:** Welded in prior to shipment
3. **Applicable Frame Series:** F, FN, MU, FE, DE
4. **Profile variations:** SR: Single Rabbet  
DR: Double Rabbet (equal & unequal)  
CO: Cased Open  
NOTE: profile must have a return
5. **Frame depths:** All frame depths
6. **Face variations:** Fits all face variations  
Ordered specifically to fit face
7. **Frame attachment:** Must be welded to frame
8. **Application:** Arrives at jobsite welded into frame
9. **Wall construction:** Closed steel stud walls
10. **Fire label applications:** UL/WH 3 hour max.
11. **Base anchor:** See page 92 for base anchor details

## Recessed steel stud

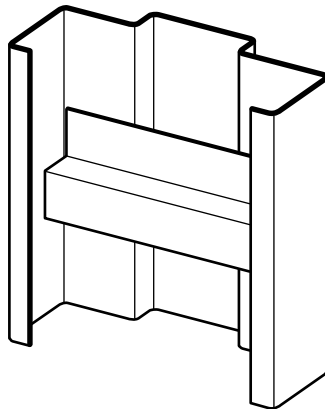

1. **Material:** 16 Ga. Galvannealed Steel
2. **Supplied:** Welded in prior to shipment
3. **Applicable Frame Series:** F, FN, MU, FE, DE
4. **Profile variations:** SR: Single Rabbet  
DR: Double Rabbet (equal & unequal)  
CO: Cased Open  
NOTE: profile must have a return
5. **Frame depths:** All frame depths
6. **Face variations:** Fits all face variations  
Ordered specifically to fit face
7. **Frame attachment:** Must be welded to frame
8. **Application:** Arrives at jobsite welded into frame
9. **Wall construction:** Closed steel stud walls
10. **Fire label applications:** UL/WH 3 hour max.
11. **Base anchor:** See page 92 for base anchor details

## Field adjustable base

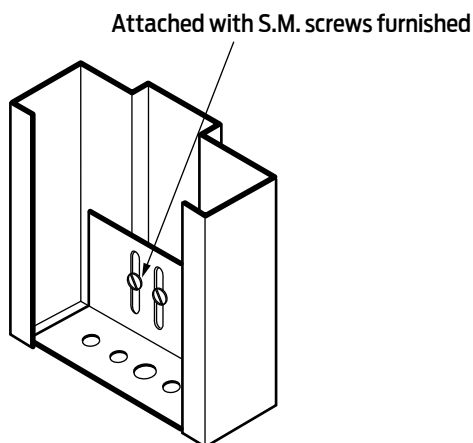

Maximum adjustment 1-3/8" (35mm) below bottom of frame

- |                                     |                                                                                                                                                                                                                        |
|-------------------------------------|------------------------------------------------------------------------------------------------------------------------------------------------------------------------------------------------------------------------|
| 1. <b>Material:</b>                 | 16 Ga. Galvannealed Steel                                                                                                                                                                                              |
| 2. <b>Supplied:</b>                 | Shipped loose for field installation                                                                                                                                                                                   |
| 3. <b>Applicable Frame Series:</b>  | F, MU                                                                                                                                                                                                                  |
| 4. <b>Profile variations:</b>       | DR: Double Rabbet (equal & unequal)                                                                                                                                                                                    |
| 5. <b>Frame depths:</b>             | All frame depths<br>Ordered to specifically fit frame depths                                                                                                                                                           |
| 6. <b>Face variations:</b>          | Fits all face variations                                                                                                                                                                                               |
| 7. <b>Frame attachment:</b>         | Retaining clip is factory welded into each jamb.<br>Adjustable anchor is field attached and adjusted during installation.                                                                                              |
| 8. <b>Application:</b>              | Anchor angle ship loose to jobsite, field attached and adjusted.<br>Adjustable base anchors are manufactured to fit the frame profile, depth and profile variations which must be specified when ordering this anchor. |
| 9. <b>Wall construction:</b>        | Masonry block or brick, steel stud                                                                                                                                                                                     |
| 10. <b>Fire label applications:</b> | UL/WH 3 hour max.                                                                                                                                                                                                      |

## Fixed base

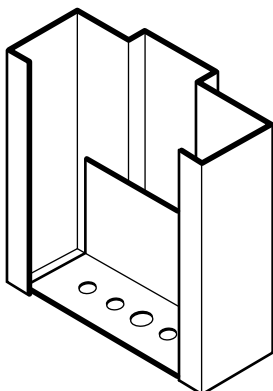

- |                                     |                                                                            |
|-------------------------------------|----------------------------------------------------------------------------|
| 1. <b>Material:</b>                 | 16 Ga. Galvannealed Steel                                                  |
| 2. <b>Supplied:</b>                 | Welded in prior to shipment                                                |
| 3. <b>Applicable Frame Series:</b>  | F, FN, MU, FE, DE                                                          |
| 4. <b>Profile variations:</b>       | SR: Single Rabbet<br>DR: Double Rabbet (equal & unequal)<br>CO: Cased Open |
| 5. <b>Frame depths:</b>             | All frame depths<br>Ordered to specifically fit frame depths               |
| 6. <b>Face variations:</b>          | Fits all face variations                                                   |
| 7. <b>Frame attachment:</b>         | Must be welded to frame                                                    |
| 8. <b>Application:</b>              | Arrives at jobsite welded into frame                                       |
| 9. <b>Wall construction:</b>        | Masonry block or brick, steel stud                                         |
| 10. <b>Fire label applications:</b> | UL/WH 3 hour max.                                                          |



## Anchor details

## Compression jamb

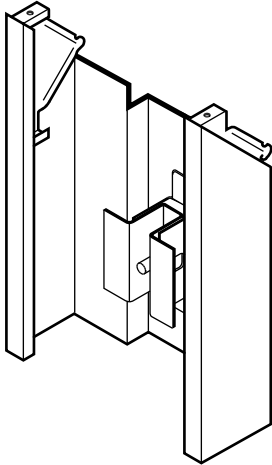

1. **Material:** 16 Ga. Galvannealed Steel
2. **Supplied:** Factory welded in prior to shipment
3. **Applicable Frame Series:** DW, K
4. **Profile variations:** SR: Single Rabbet  
DR: Double Rabbet (equal & unequal)  
CO: Cased Open  
NOTE: profile must have a backbend
5. **Frame depths:** All DW & K frame depths  
For frame depths over 9", 2 anchors welded at each anchor location
6. **Face variations:** 2" face only
7. **Frame attachment:** Must be welded to frame
8. **Application:** Arrives at jobsite welded into frame
9. **Wall construction:** Wood or steel stud walls
10. **Fire label applications:** UL/WH 1-1/2 hour max.
11. **Base anchor:** See page 94 for sill anchor details

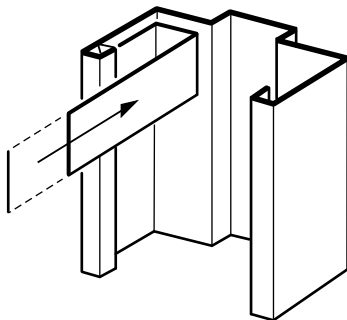
Security anchor (optional)  
for DW and K Series

Security anchor is field installed in the strike jamb directly above or below the strike preparation.

1. **Material:** 24 Ga. Galvannealed Steel
2. **Supplied:** Shipped loose for field installation
3. **Applicable Frame Series:** DW, K
4. **Profile variations:** SR: Single Rabbet  
DR: Double Rabbet (equal & unequal)  
CO: Cased Open  
NOTE: profile must have a backbend
5. **Frame depths:** All frame depths
6. **Face variations:** 2" face only
7. **Frame attachment:** Lock-in
8. **Application:** Ship loose to jobsite, field installed
9. **Wall construction:** Wood or steel stud walls
10. **Fire label applications:** UL/WH 1-1/2 hour max.

## Adjustable base for DW Series

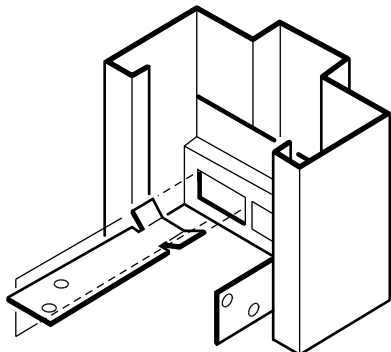

1. **Material:** 16 Ga. Galvannealed Steel
2. **Supplied:** Shipped loose for field installation
3. **Applicable Frame Series:** DW
4. **Profile variations:** SR: Single Rabbet  
DR: Double Rabbet (equal & unequal)  
CO: Cased Open  
NOTE: profile must have a backbend
5. **Frame depths:** All frame depths
6. **Face variations:** 2" face only
7. **Frame attachment:** Retaining clip is factory welded into each jamb. Adjustable anchor is field attached and adjusted during installation.
8. **Application:** Anchor angle ship loose to jobsite, field attached and adjusted.
9. **Wall construction:** Wood or steel stud walls
10. **Fire label applications:** UL/WH 1-1/2 hour max.

## Base for K Series

Factory prepared holes: screws by others

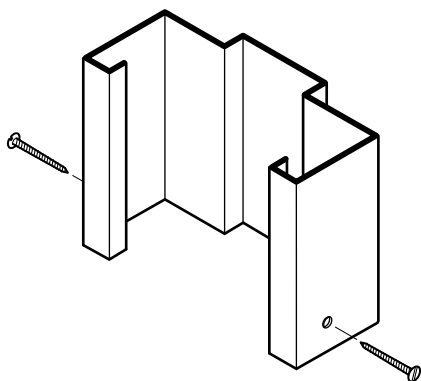

1. **Material:** #8 Phillips Flat Head Sheet Metal Screws (2 per jamb).  
Supplied by others.
2. **Supplied:** Base of each jamb is factory prepared with a countersunk hole to accept a #8 Phillips Flat Head Screw. Supplied by others.
3. **Applicable Frame Series:** K
4. **Profile variations:** SR: Single Rabbet  
DR: Double Rabbet (equal & unequal)  
CO: Cased Open  
NOTE: profile must have a backbend
5. **Frame depths:** All frame depths
6. **Face variations:** Fits all face variations  
Ordered specifically to fit face
7. **Frame attachment:** Counter sunk holes pierced onto the face at the factory
8. **Application:** Field attached
9. **Wall construction:** Wood or steel stud walls
10. **Fire label applications:** UL/WH 1-1/2 hour max.

## Mullion base

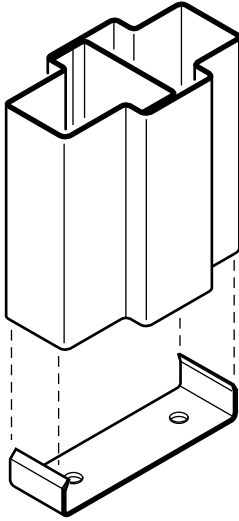

1. **Material:** 16 Ga. Galvannealed Steel
2. **Supplied:** Shipped loose for field installation
3. **Applicable Frame Series:** F Series Hollow Metal Mullions
4. **Profile variations:** SR: Single Rabbet  
DR: Double Rabbet  
(equal & unequal)
5. **Frame depths:** All frame depths
6. **Face variations:** Ordered specifically to fit face
7. **Frame attachment:** Anchor to floor, mullion slides over
8. **Application:** Ship loose to jobsite, field installed
9. **Floor construction:** All
10. **Fire label applications:** UL/WH 3 hour max.

## Sill section base

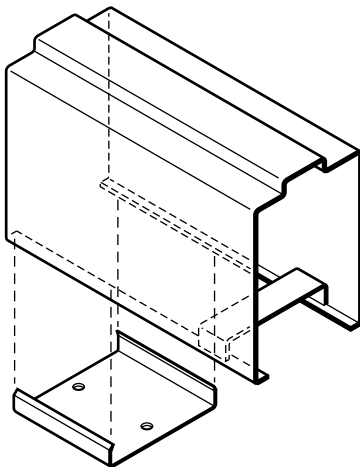

1. **Material:** 16 Ga. Galvannealed Steel
2. **Supplied:** Shipped loose for field installation
3. **Applicable Frame Series:** F, FN,
4. **Profile variations:** SR: Single Rabbet  
DR: Double Rabbet  
(equal & unequal)
5. **Frame depths:** All frame depths
6. **Face variations:** Fits all pace variations
7. **Frame attachment:** Anchor to floor, sill snaps on top
8. **Application:** Ship loose to jobsite, field installed
9. **Floor construction:** All
10. **Fire label applications:** UL/WH 3 hour max.

## Corner post base

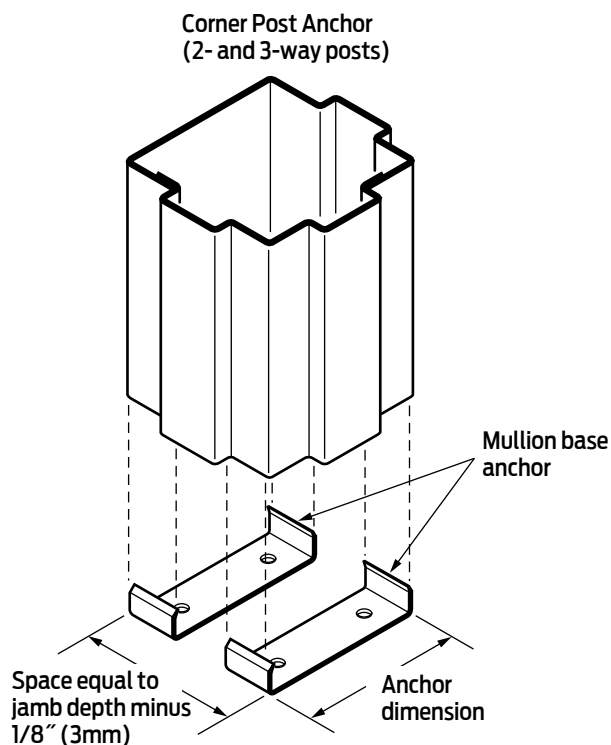

- |                                     |                                               |
|-------------------------------------|-----------------------------------------------|
| 1. <b>Material:</b>                 | 12 Ga. Galvanized Steel                       |
| 2. <b>Supplied:</b>                 | Shipped loose for field installation          |
| 3. <b>Applicable Frame Series:</b>  | Corner posts                                  |
| 4. <b>Profile variations:</b>       | DR: Double Rabbet<br>(equal & unequal)        |
| 5. <b>Frame depths:</b>             | All frame depths                              |
| 6. <b>Face variations:</b>          | Ordered specifically to fit face              |
| 7. <b>Frame attachment:</b>         | Attached to floor, corner post<br>slides over |
| 8. <b>Application:</b>              | Ship loose to jobsite, field installed        |
| 9. <b>Floor construction:</b>       | All                                           |
| 10. <b>Fire label applications:</b> | UL/WH Approved                                |