



47986705

# 7547

# VON DUPRIN®

Concealed Vertical Rod Exit Device

Installation Instructions

### Devices covered by these instructions:

- 7547 Concealed Vertical Rod Exit Device
- 7547-F Fire Concealed Vertical Rod Exit Device
- CD7547 Concealed Vertical Rod Exit Device
- QEL7547/47-F Concealed Vertical Rod Exit Device

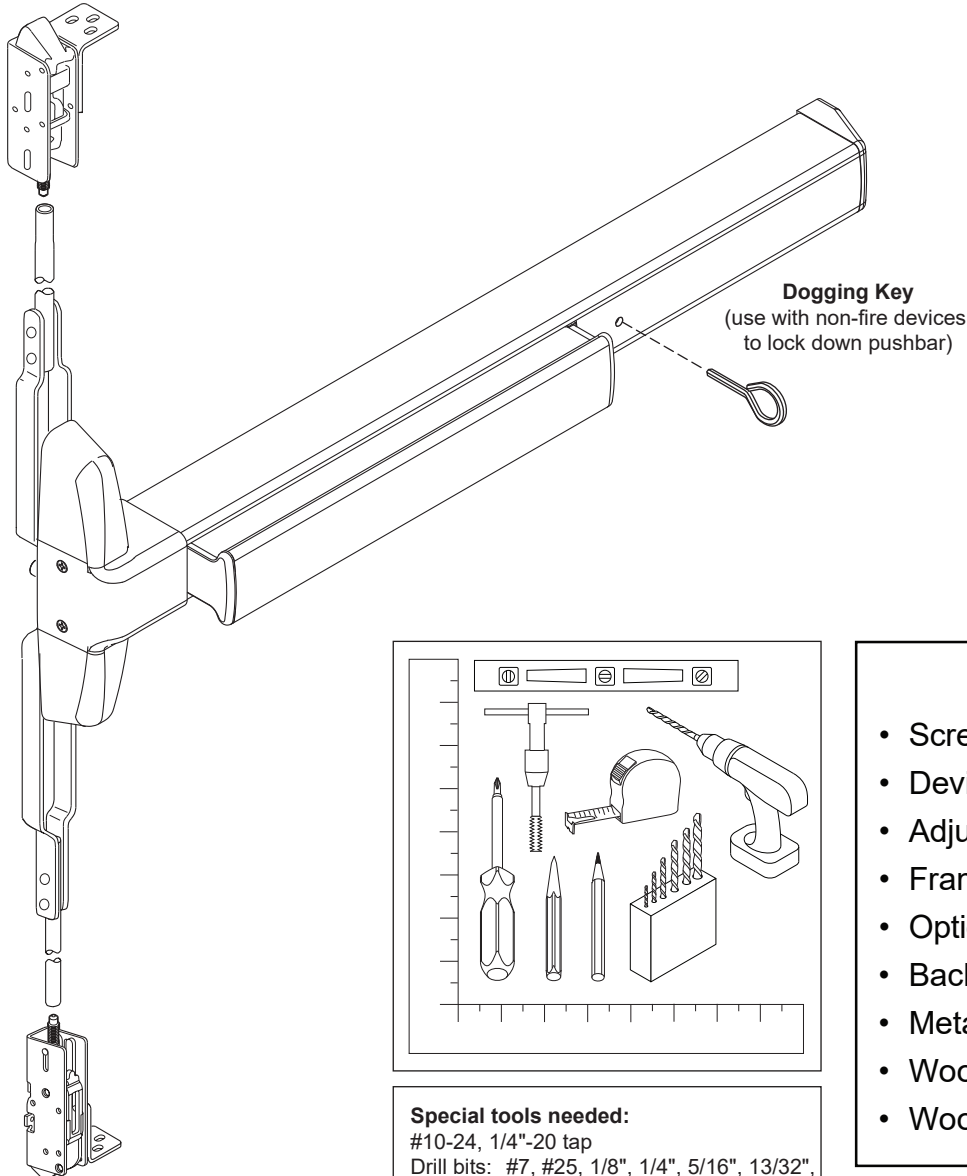











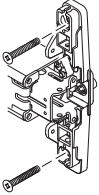
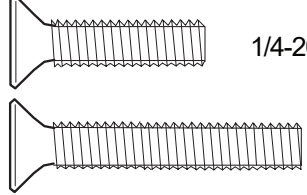
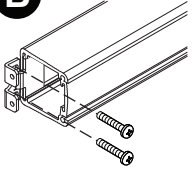
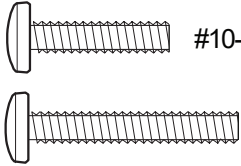

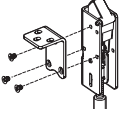
### Index:

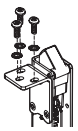
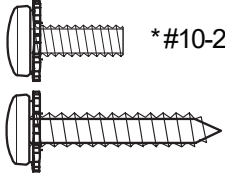
- Screw chart ..... 2
- Device installation ..... 3-5
- Adjust rods ..... 6
- Frame preparation ..... 7
- Optional equipment ..... 8
- Backset information ..... 9
- Metal door templates ..... 11-12
- Wood door preparation .... 13-14
- Wood door templates ..... 15-16

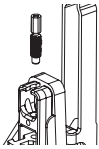
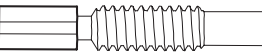
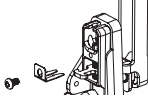

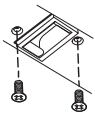
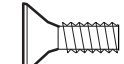
**Customer Service**  
1-877-671-7011    www.allegion.com/us

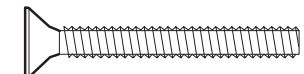
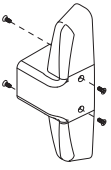
# SCREW CHART

<b>A</b> 		1/4-20 x 1" _____ 1/4-20 x 1-1/2" _____	Trim mount or sex bolts: (1-3/4" door) (2-1/4" door)
<b>B</b> 		#10-24 X 3/4" _____ #10-24 X 1-1/8" _____	Surface mount or Sex bolts (1-3/4" door) Sex bolts (2-1/4" door)
<b>C</b> 		#10-16 X 3/8" Thread cutting _____	End cap
<b>D</b> 		#10-32 X 1/4" _____	Bracket to latch
<b>E</b> 		* #10-24 X 1/2" _____ * #10 X 1" Wood screw _____ *Used with external tooth lock washer	Bracket to door Bracket to door
<b>F</b> 		#10-32 X 3/8" Socket head _____	Rod attachment
<b>G</b> 		Rod adjusting screw _____	Rod length adjustment
<b>H</b> 		#8-32 X 5/16" _____	Retaining clip
<b>I</b> 		#10-24 X 1/2" _____	338 Strike
<b>J</b> 		#10-24 X 1-1/2" _____	Ratchet release
<b>K</b> 		#8-18 x 3/8" Thread cutting _____	Center case cover

This page intentionally blank.

# 1

## Draw horizontal and vertical device center lines (☉).

See "Backset information" on page 10

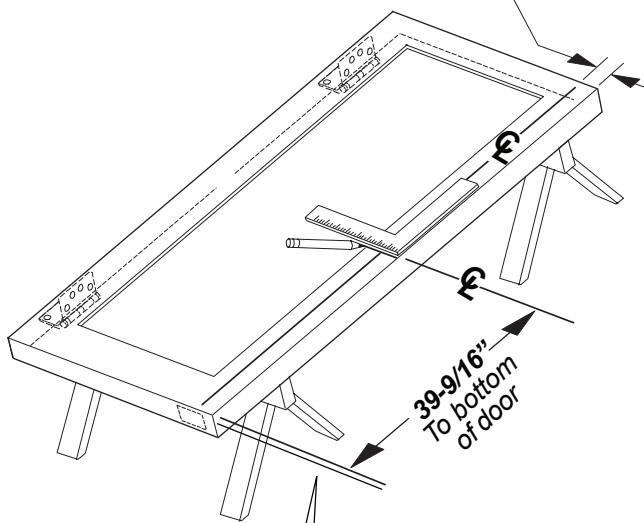

Once hung, door should have 1/4" undercut (gap) at bottom of door to finished floor

RHR shown  
(LHR opposite)

# 2

## Place paper device template on door and prepare door.

For wood doors - See pages 13 & 14 for special door preparation instructions.

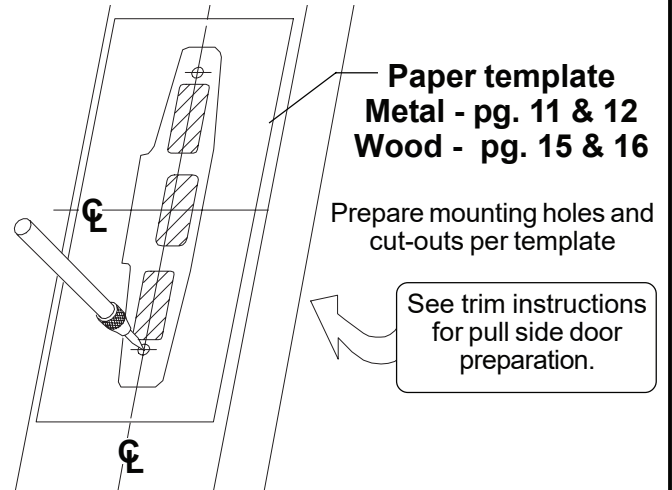

RHR shown  
(LHR opposite)

# 3

## Prepare top and bottom of door for latch mounting brackets.

### Latch cases (drill top and bottom of door)

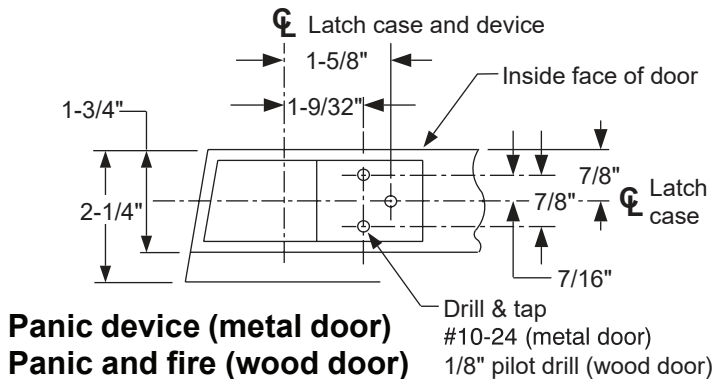
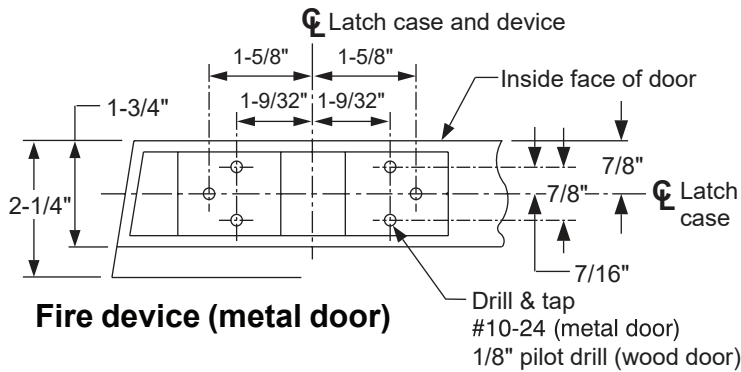

# 4

## Drill ratchet release hole in door.

11/16"	1/2" Stop height
13/16"	5/8" Stop height
15/16"	3/4" Stop height

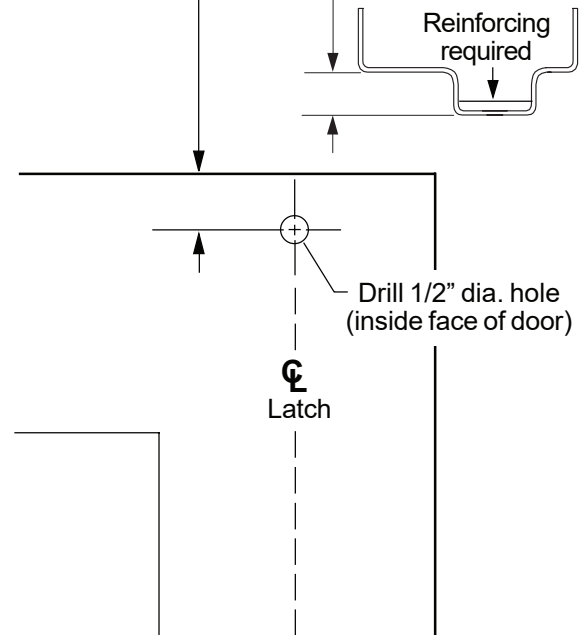

# 5

## Measure to determine length to cut device.

**1-3/16"** minimum clearance  
(with end cap removed)

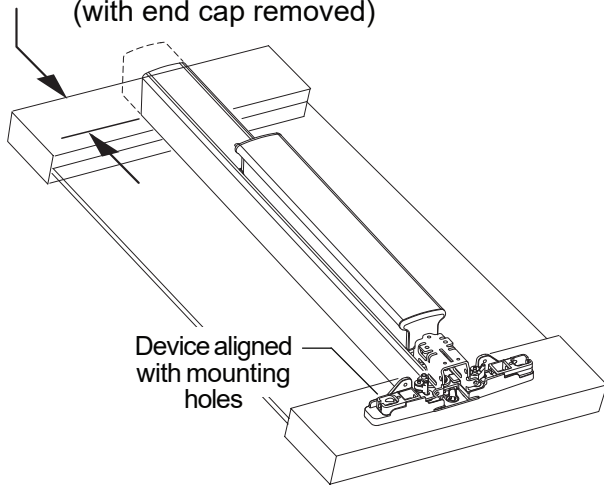

Device aligned with mounting holes

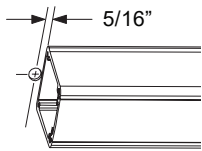

### Note

If 5/8" diameter wire access hole has been predrilled in door, cut device 5/16" from center of hole.

# 6

## Cut device to length.

### Prepare device for cutting

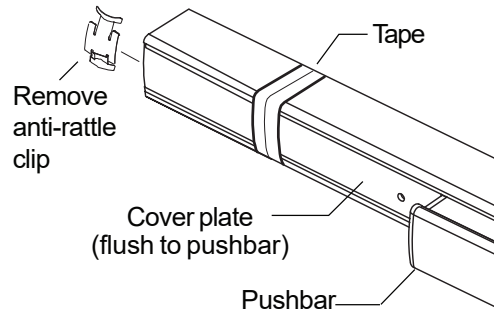

Remove anti-rattle clip

Cover plate (flush to pushbar)

Pushbar

### Cut device square

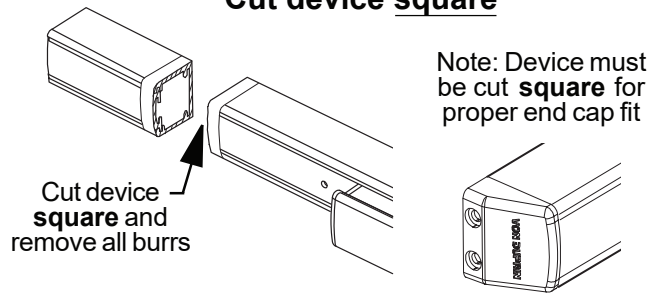

Cut device square and remove all burrs

Note: Device must be cut square for proper end cap fit

# 7

## Assemble rods and latches and adjust length.

Follow white and brown instruction cards on rods to set initial rod length

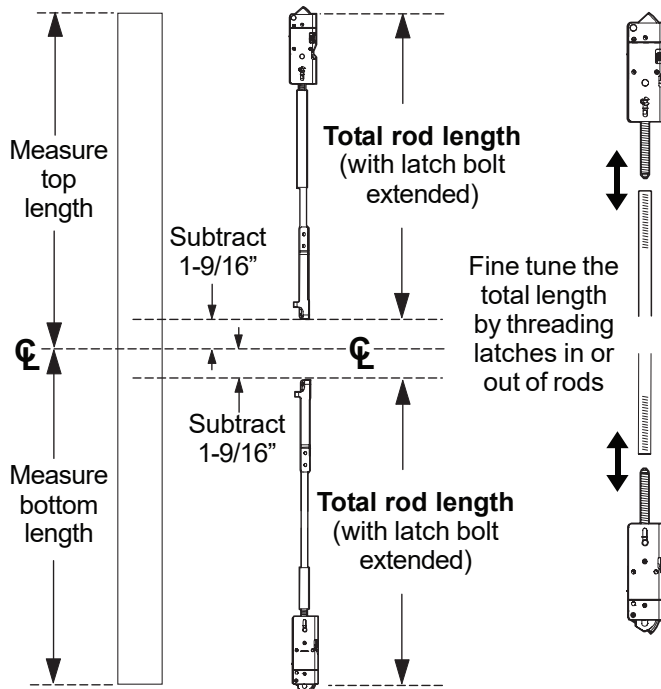

# 8

## Install rods as shown.

Rods are shipped with L-bracket attached. Insert rods with L-bracket pointing toward lock stile. Rotate rod until L-bracket protrudes through door cutout. If this is not possible, remove L-bracket and re-insert rod, then re-attach L-brackets.

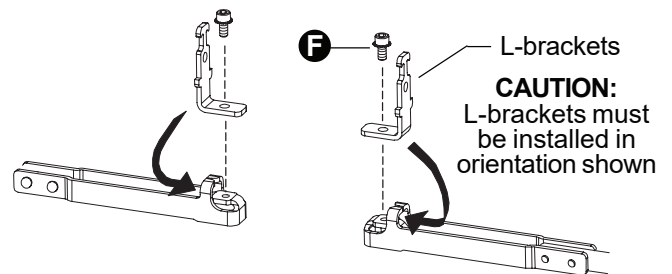

**NOTE:** Fire devices on metal doors use brackets on both sides of latches

Top latch & rod

Bottom latch & rod

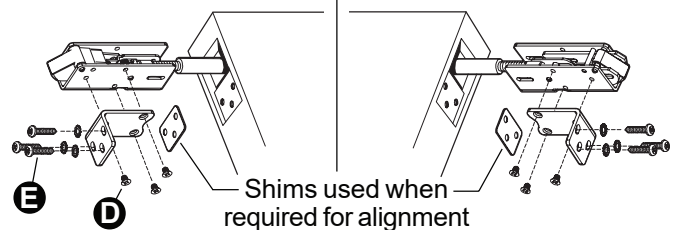

Shims used when required for alignment

# 9

## Install tailpiece guide and attach rods to center case.

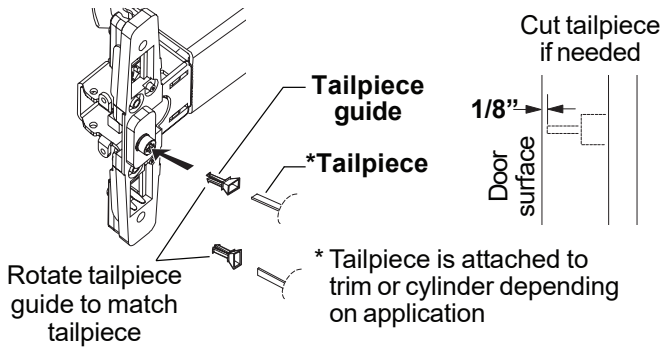

Place device over L-brackets and install adjusting screws, then install retainers and locking screws

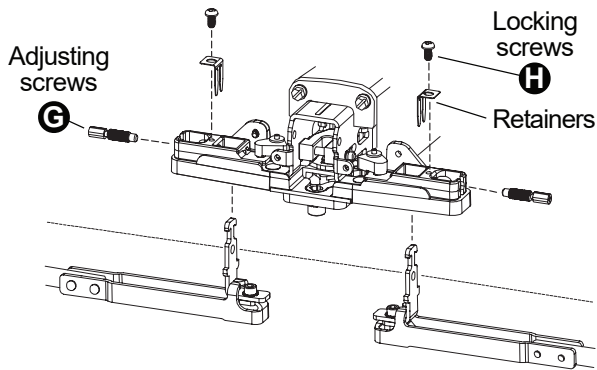

# 10

## Secure device to door and mount door to frame.

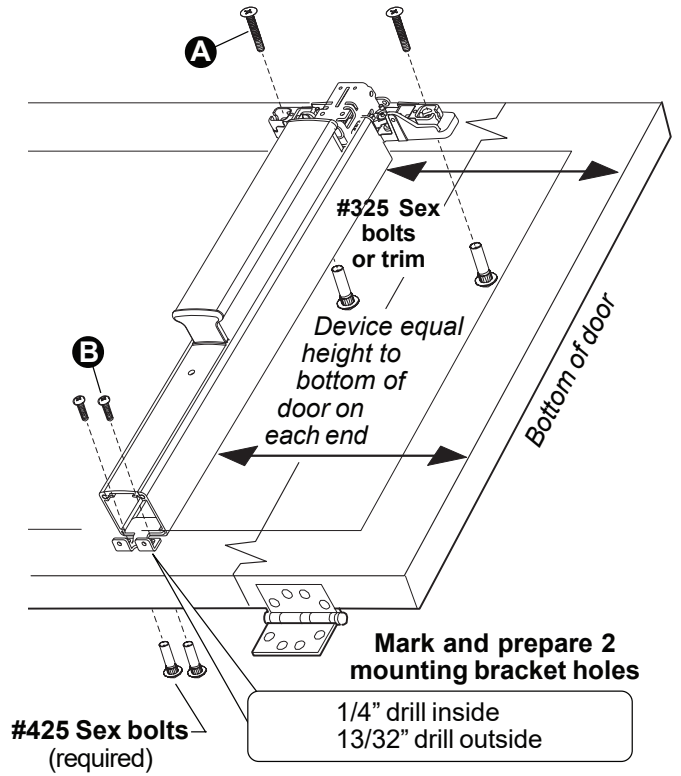

# 11

## Install top strike and ratchet release.

### 338 Top strike

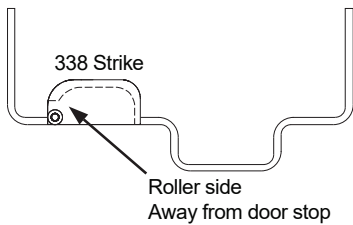
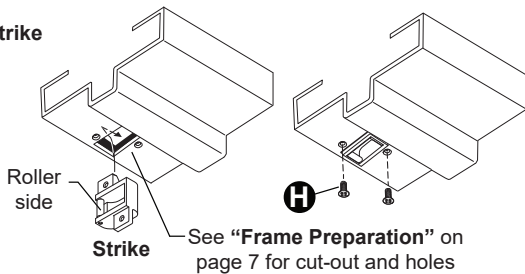

### Ratchet release

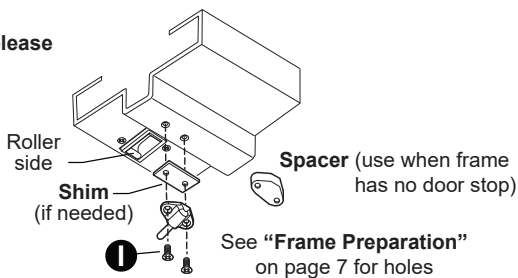

# 12

## Install bottom strike or prepare threshold.

385-A bottom strike has two pieces. Grout bottom piece into floor and attach top piece to bottom with screw through slot.

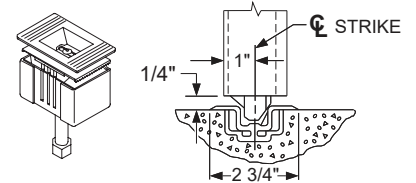

### Threshold application

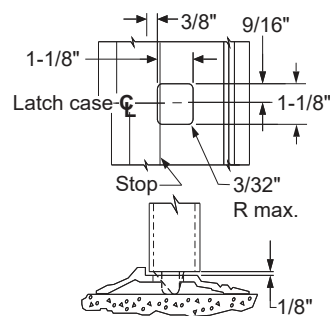

### Flat threshold application

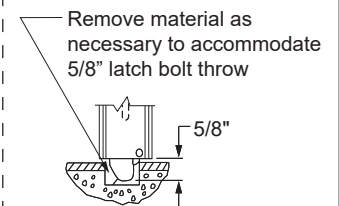

Note: Thresholds are not to be used with 7547-F.

Hurricane applications use threshold with 304L bottom strike

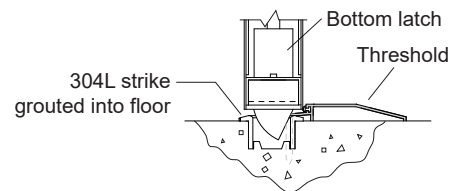

# ADJUST RODS

1. Open door and release top latch bolt as shown (Figure 1).

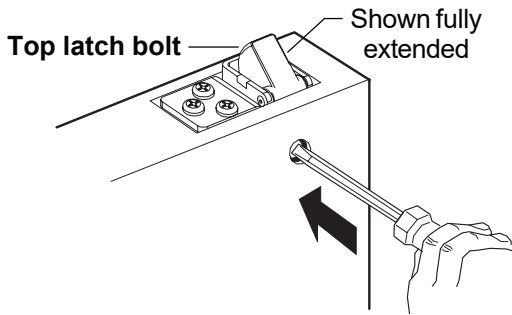

**Figure 1**

2. Remove bottom locking screw and retaining clip (Figure 2).
3. Disconnect bottom vertical rod by removing bottom adjusting screw.
4. Loosen top locking screw.
5. Rotate top adjusting screw clockwise until top latch bolt is fully extended (Figure 1).

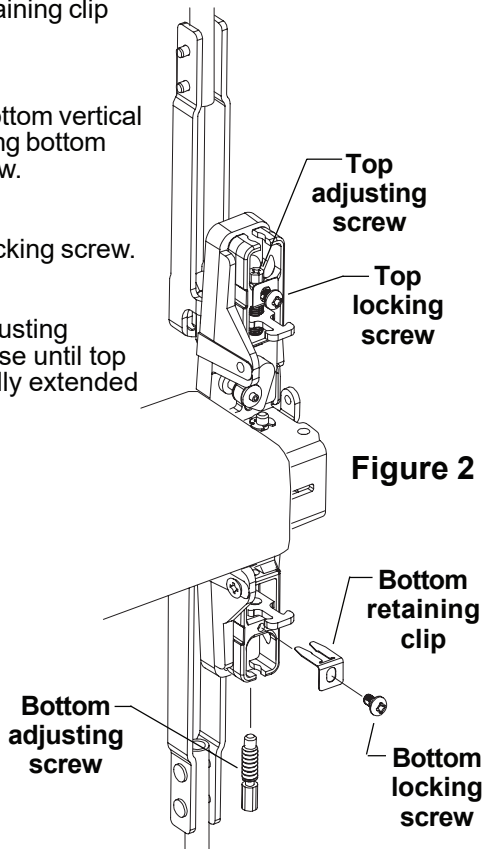

**Figure 2**

6. Check top latch bolt for deadlocking (latch bolt should not push in).

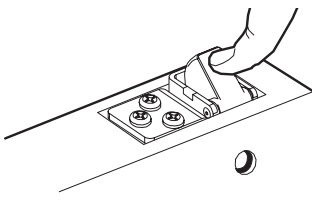

7. Turn top locking screw in against flat on adjusting screw. Do not over-tighten.

8. Depress pushbar and release.
9. Make sure top latch bolt stays retracted as shown.

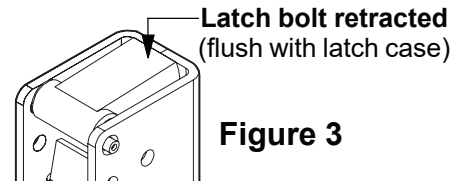

**Figure 3**

10. Install bottom adjusting screw through bottom rod and install bottom retaining clip and locking screw (Figure 2).
11. With top latch bolt still retracted, adjust bottom rod so latch bolt clears floor and bottom strike.

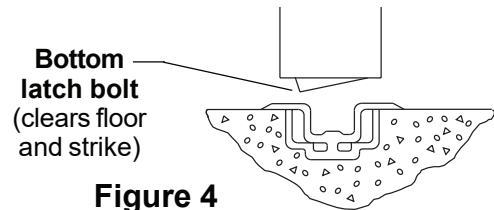

**Figure 4**

12. Close door and check bottom latch bolt for dead locking.
13. After bottom rod is fully adjusted per steps 11 and 12, turn bottom locking screw in against flat on adjusting screw. Do not over-tighten.
14. Check device operation by opening and closing door several times from the outside.

## Redo adjustment procedure if :

- Top latchbolt is not held retracted
- Bottom latchbolt does not clear floor and bottom strike

15. Install end cap and center case covers.

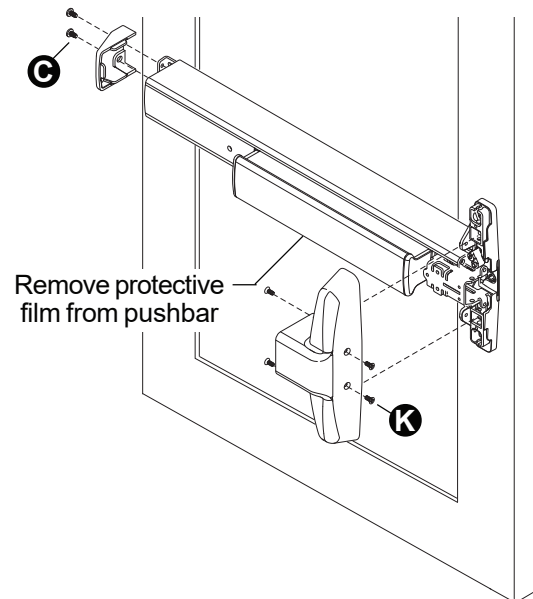

# FRAME PREPARATION

## 338 Top strike

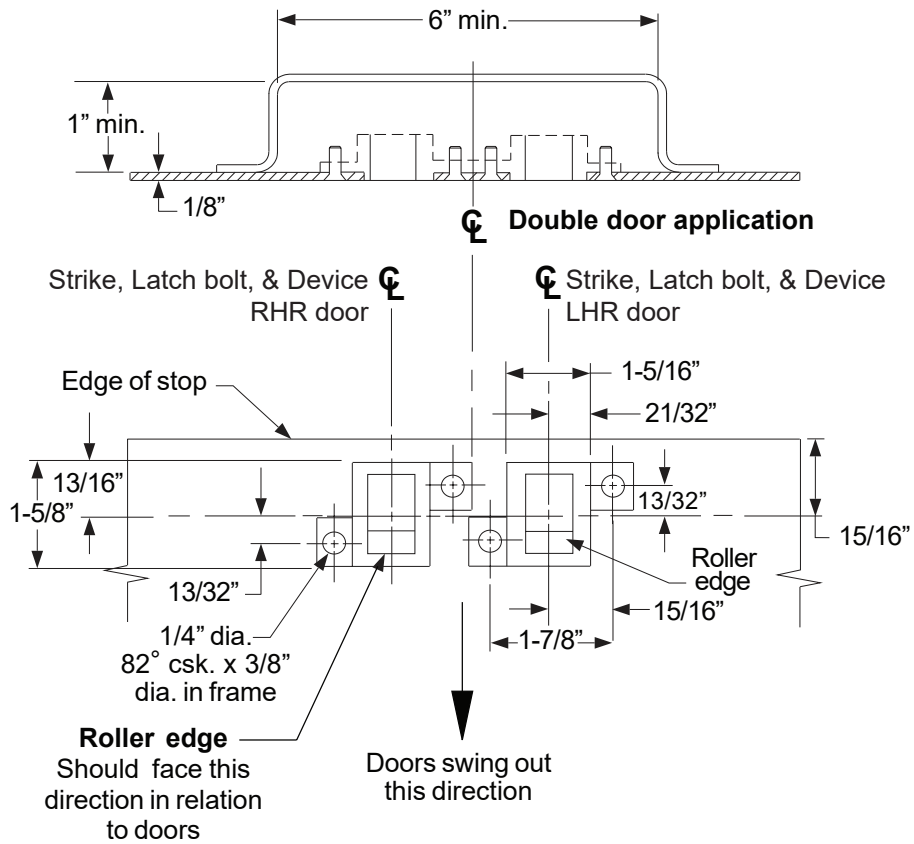

## Ratchet release

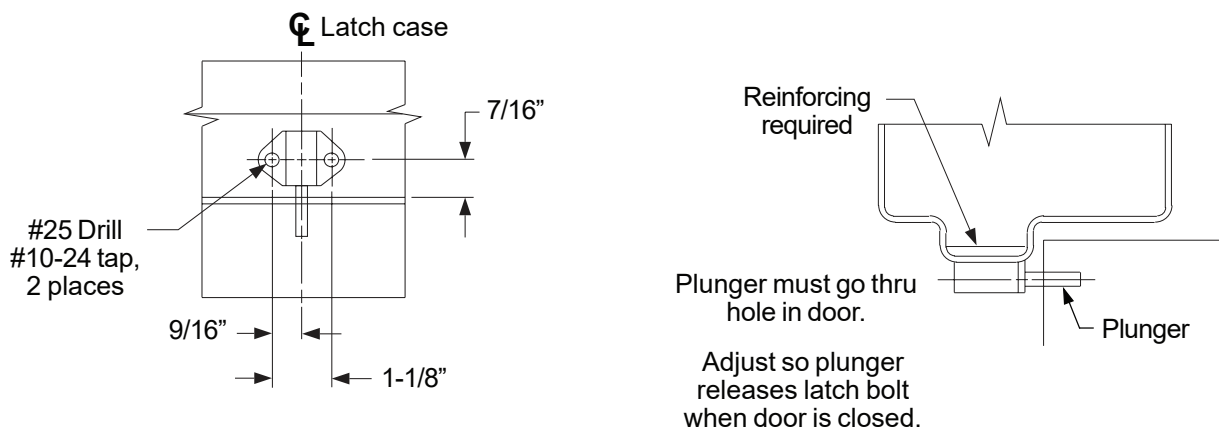



# OPTIONAL EQUIPMENT

## CD (CYLINDER DOGGING)

1. Remove mortise cylinder cam and reinstall in reverse (Figure 1).
2. Insert key and rotate cam to install the cylinder to the cover plate (Figure 2).
3. Remove key to slide cover plate in position in the mechanism case.

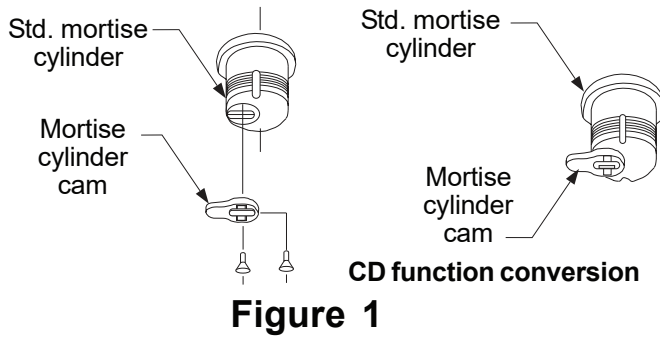

### Dogging procedure

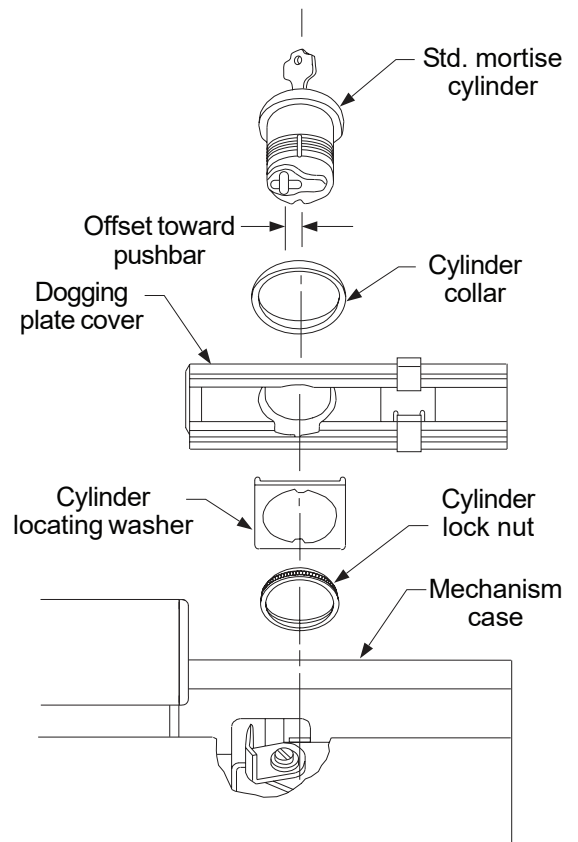
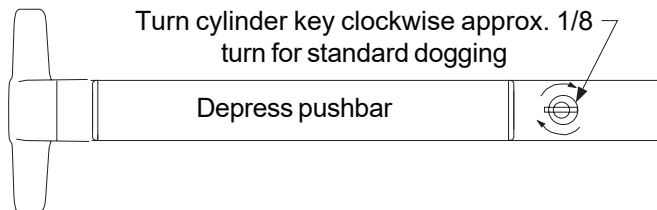
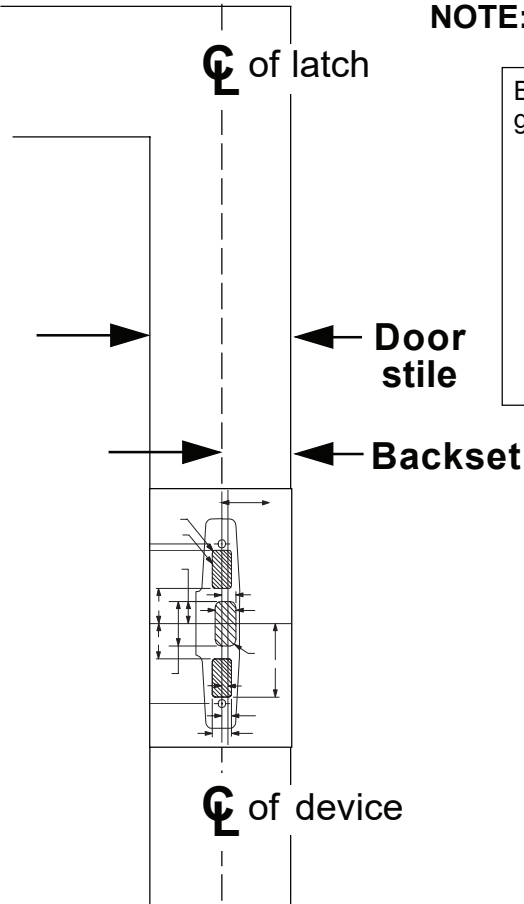

Figure 2

# BACKSET INFORMATION

**NOTE: For 2" stile doors see bottom half of page**



Backset is measured from outer edge of door as shown. Minimum stile is less glass stop (rectangular glass stop is recommended for stiles less than 2-1/8")

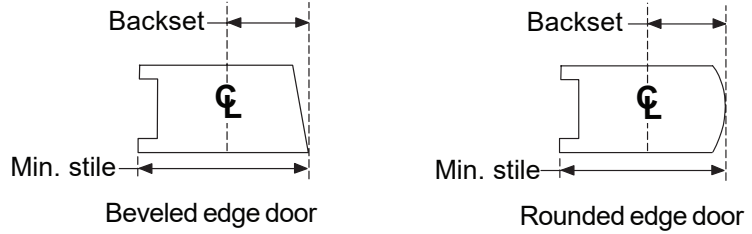

## Backset Table

Door type	Backset	Min. stile	Application
Wood	1-5/16"	NA	All
Metal	1-3/16"	2-1/8" - 2-3/4"	Two vertical rod devices (panic)
	1-1/2"	2-3/4" - 3-3/4"	
	1-7/8"	3-3/4" - 5"	
	2-1/2"	5" to flush	Single door (panic)
	1-1/2"	2-1/2" - 3-3/4"	
	1-7/8"	3-3/4" - 5"	
	2-1/2"	5" to flush	
	2-3/4"	3-5/8" to flush	Fire applications

# SPECIAL INSTRUCTIONS FOR 2" STILE DOORS

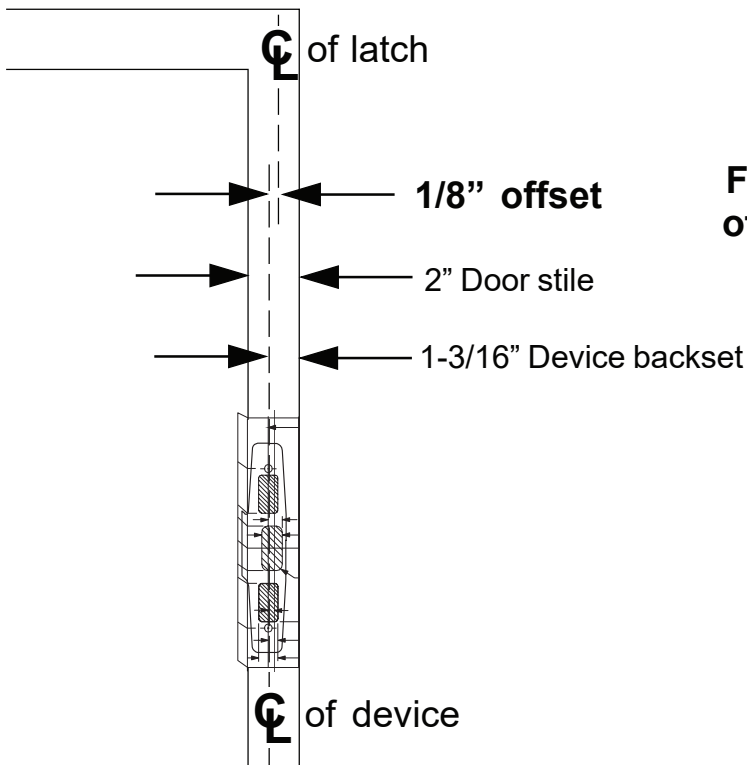

**For 2" stile doors ONLY! Latch CL is offset 1/8" from Device CL as shown**

# METAL DOOR RHR

## 7547 Device template

RHR

X

← Backset →

See "Backset Information" on page 9

Device  $\phi$

Sex bolts	5/16" drill inside 13/32" drill outside
Trim	5/16" drill inside 1/2" drill outside

For 7547-F on hollow metal doors:  
#7 drill, 1/4-20 tap if no outside trim or sex bolts are used.

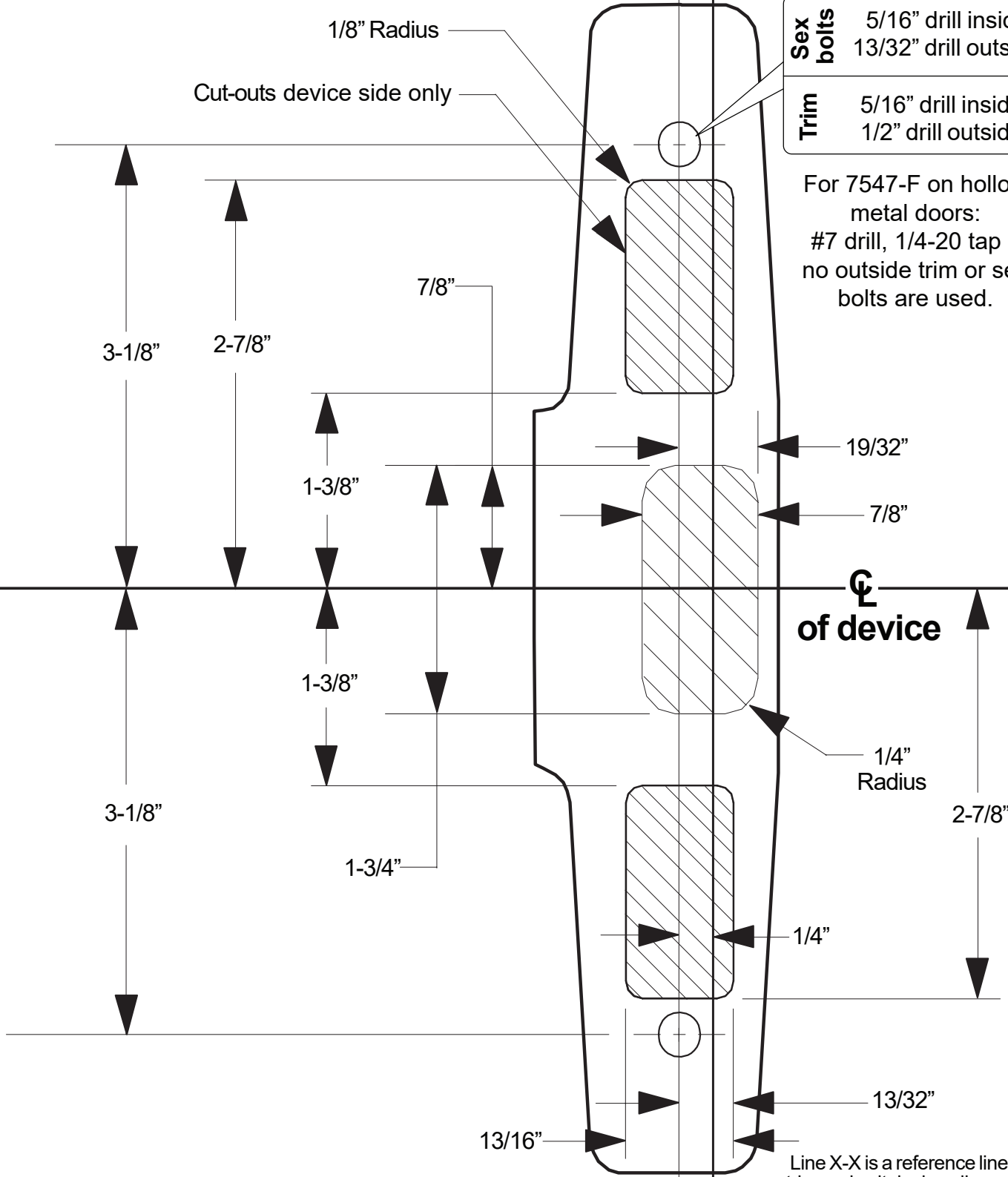

Line X-X is a reference line for trim and exit device alignment. Line X-X shown here should correspond to line X-X in the trim installation instructions

X

LHR

# METAL DOOR LHR 7547 Device template

← **Backset** →

See "Backset Information"  
on page 9

☉ of device

**Sex bolts** 5/16" drill inside  
13/32" drill outside

**Trim** 5/16" drill inside  
1/2" drill outside

For 7547-F on hollow  
metal doors:  
#7 drill, 1/4-20 tap if  
no outside trim or sex  
bolts are used.

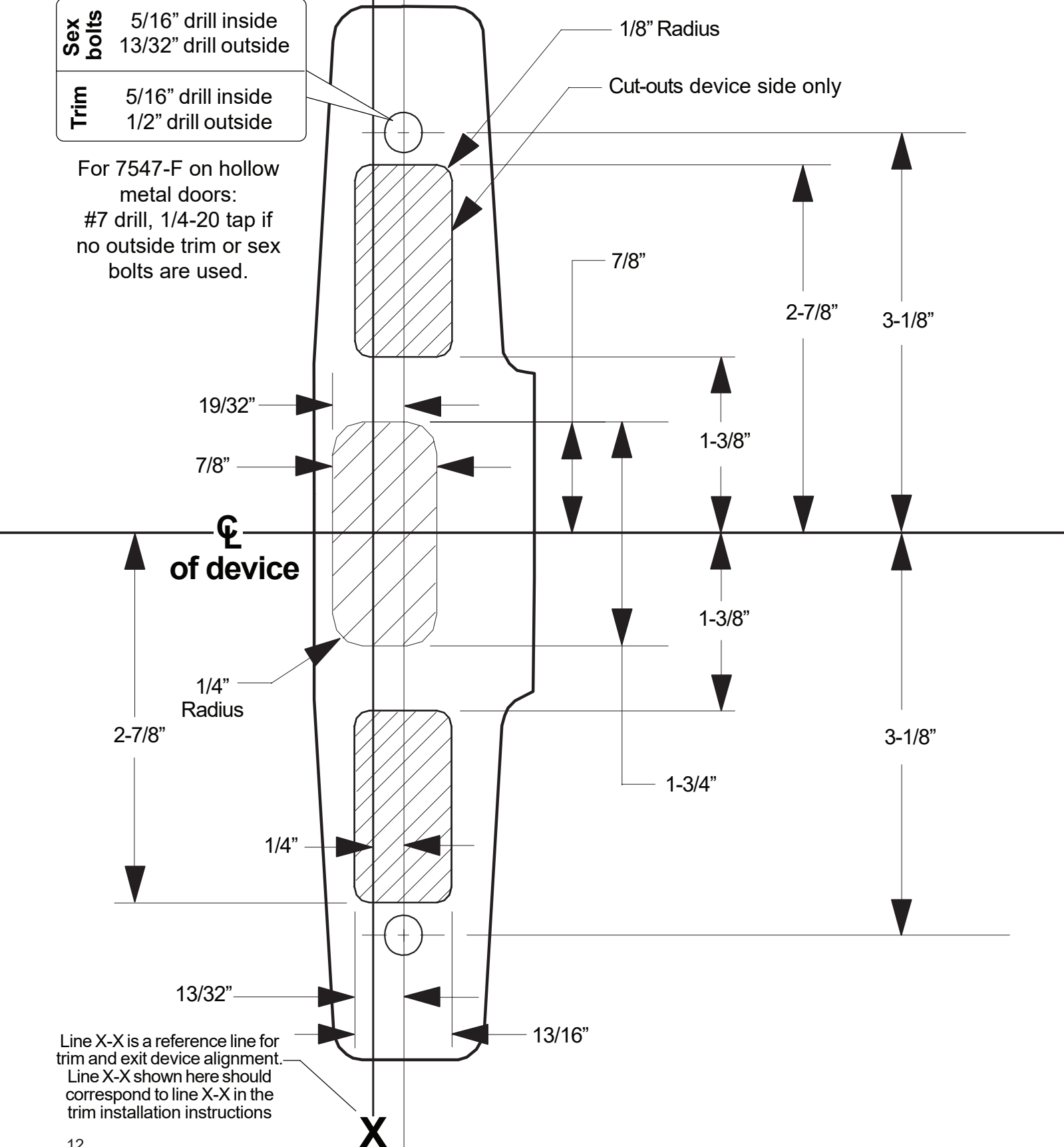

Line X-X is a reference line for  
trim and exit device alignment.  
Line X-X shown here should  
correspond to line X-X in the  
trim installation instructions

# WOOD DOOR PREPARATION - DOOR ROUTING

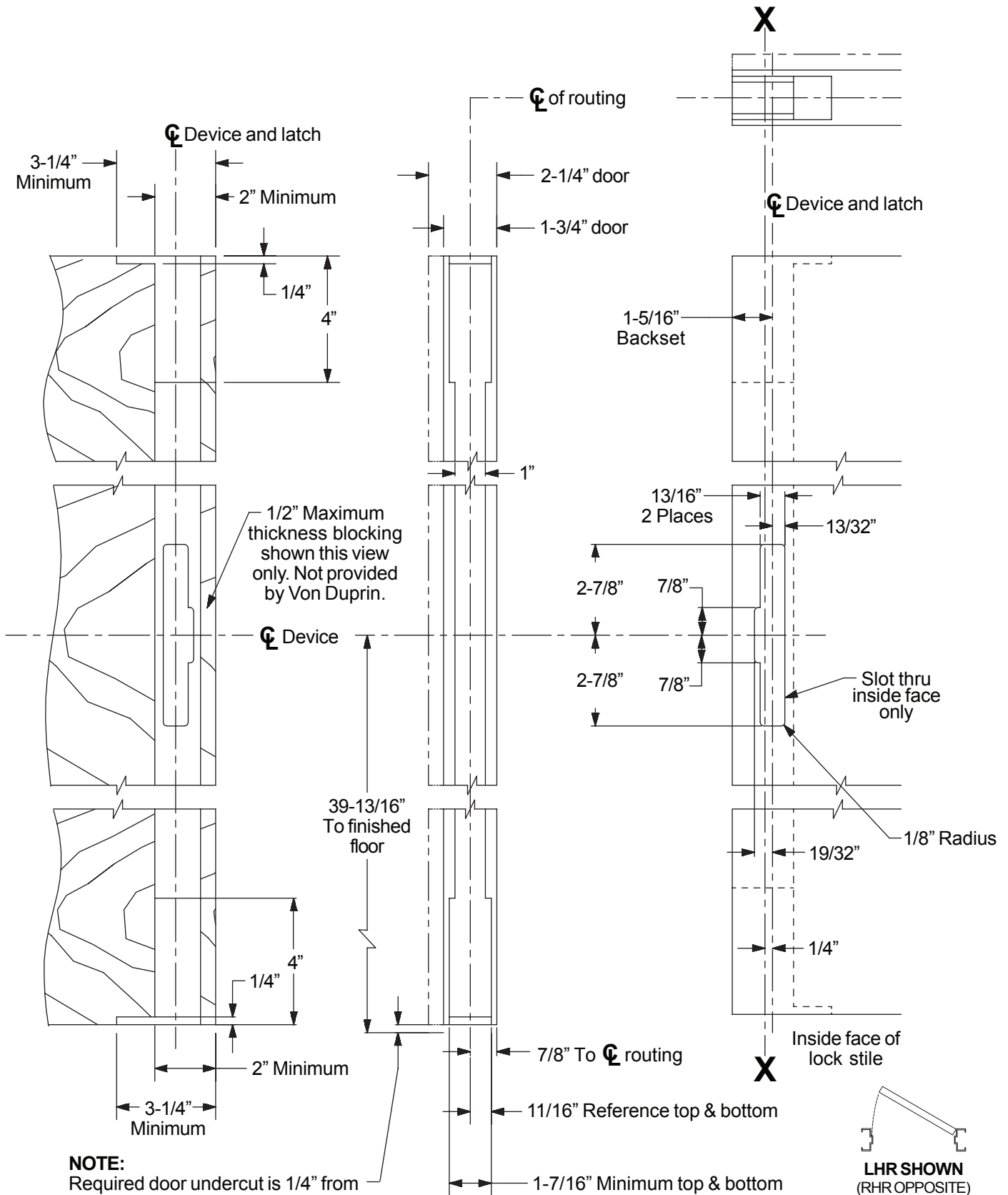

# WOOD DOOR PREPARATION - DOOR BLOCKING AND WRAP

**A.** Install door blocking. See page 13 for door blocking dimensions.

**Note:** If not using door wrap, the blocking can be installed after device is installed.

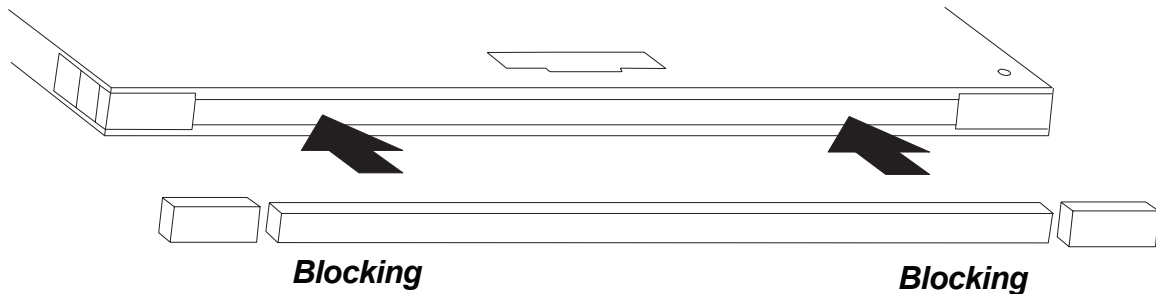

---

**B.** Install door wrap if needed. Door wrap is required for Fire rated (F) devices.

**Note:** Required on fire doors only, not supplied by Von Duprin  
(See door manufacturer's requirements)

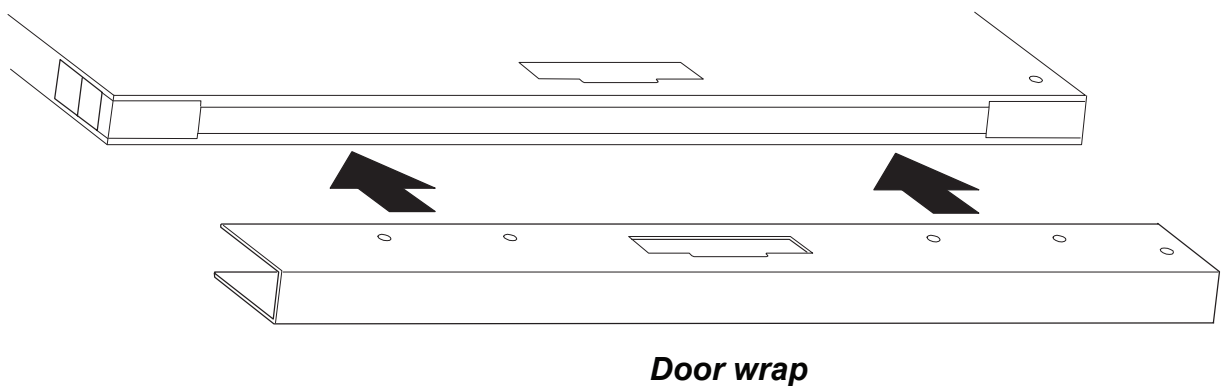

# WOOD DOOR RHR

## 7547 Device

### Template

RHR

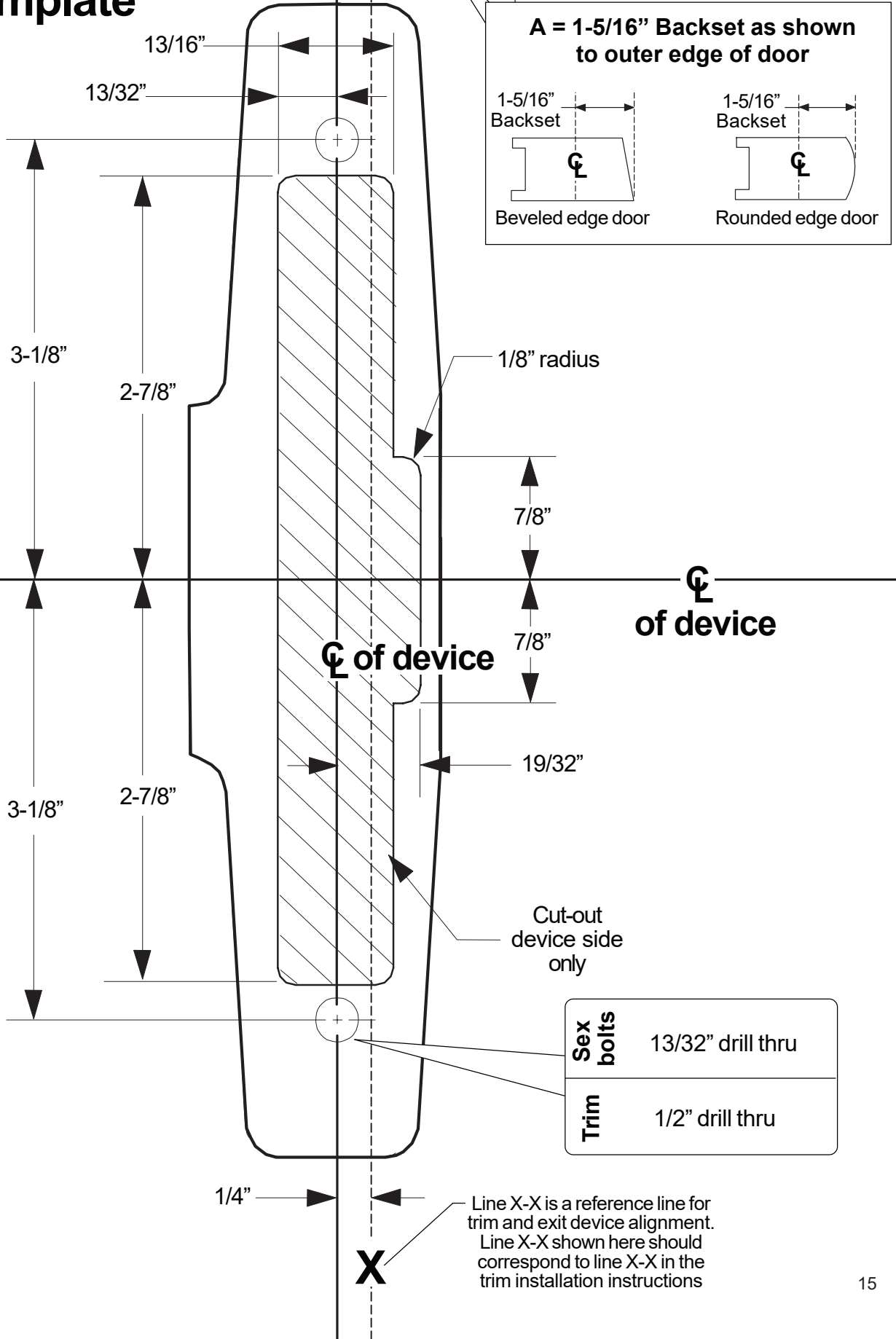

**A = 1-5/16" Backset as shown to outer edge of door**

1-5/16" Backset

Beveled edge door

1-5/16" Backset

Rounded edge door

<b>Sex bolts</b>	13/32" drill thru
<b>Trim</b>	1/2" drill thru

Line X-X is a reference line for trim and exit device alignment. Line X-X shown here should correspond to line X-X in the trim installation instructions

LHR

# WOOD DOOR LHR 7547 Device Template

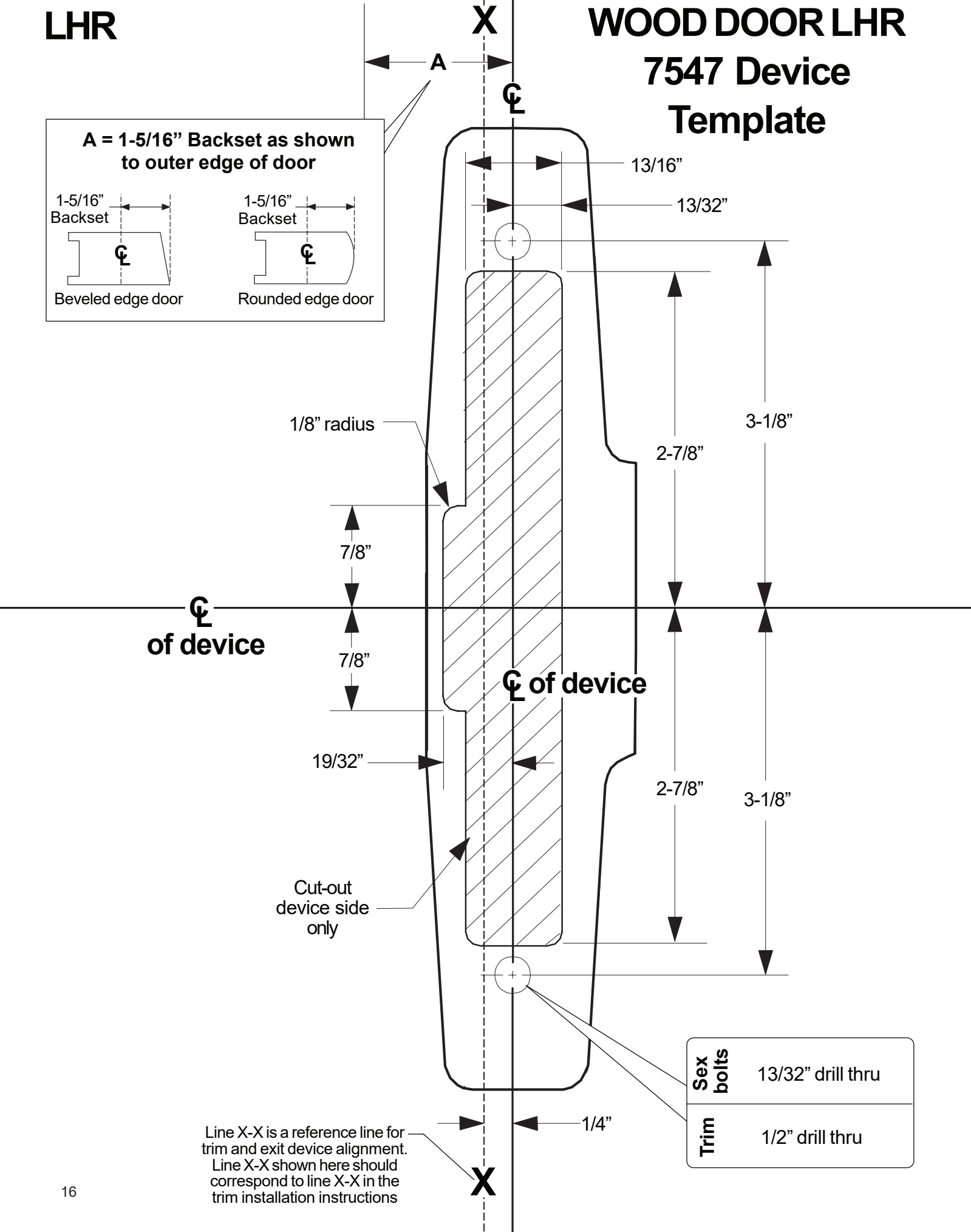
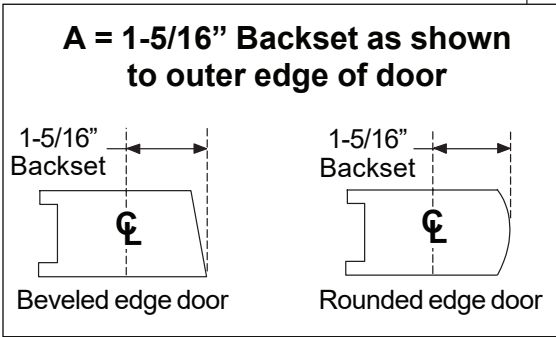

Line X-X is a reference line for trim and exit device alignment. Line X-X shown here should correspond to line X-X in the trim installation instructions

<b>Sex bolts</b>	13/32" drill thru
<b>Trim</b>	1/2" drill thru