



2720 Tobey Drive, Indianapolis, IN 46219
 Tel 1-877-671-7011 ■ Fax 800-851-0000
 Zero.Customer.Support@allegion.com
 www.zerointernational.com

Part No:

7770

Part description:

Adjustable sealing system
 jamb applied

Notes:

Provided by:

Customer name:

Job no:

Date:

Image may not be shown to scale

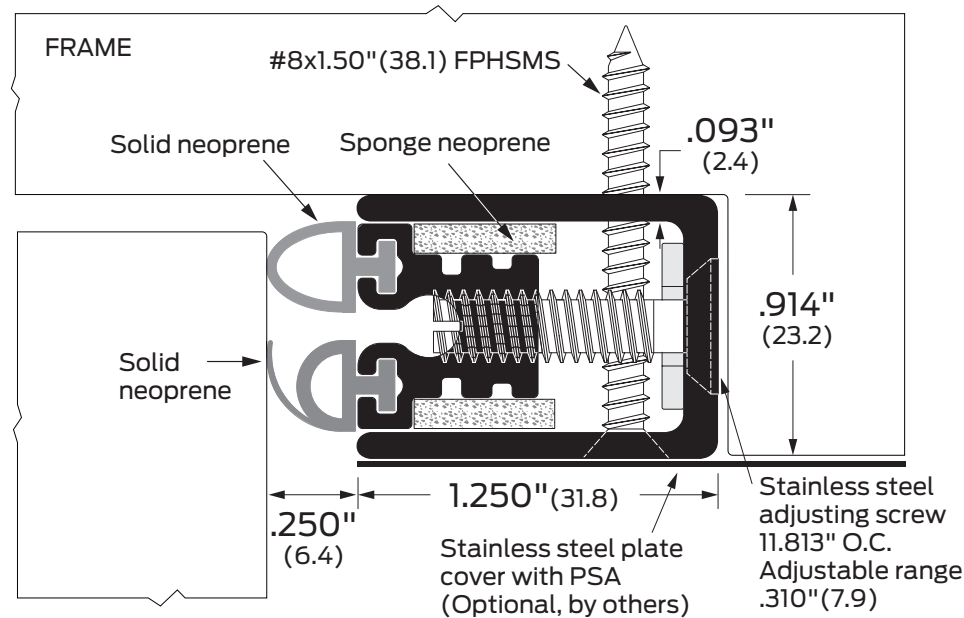

Notes:

This model is supplied with mitered corners. Extruded Bulb/Finger for double-sealing protection. 20 minute as a stop, 180 min when applied to stop.

Certifications:

- Fire rated-UL10c
- Smoke and draft control
- Sound

ANSI/BHMA:

7770AA, 7770BK, 7770D, 7770G

R3B264

Finishes:

- AA** Aluminum clear anodized
- BK** Aluminum black anodized
- D** Aluminum dark bronze anodized
- G** Aluminum gold anodized

Options:

- S** Order as a set
- SEC** Security screws

